

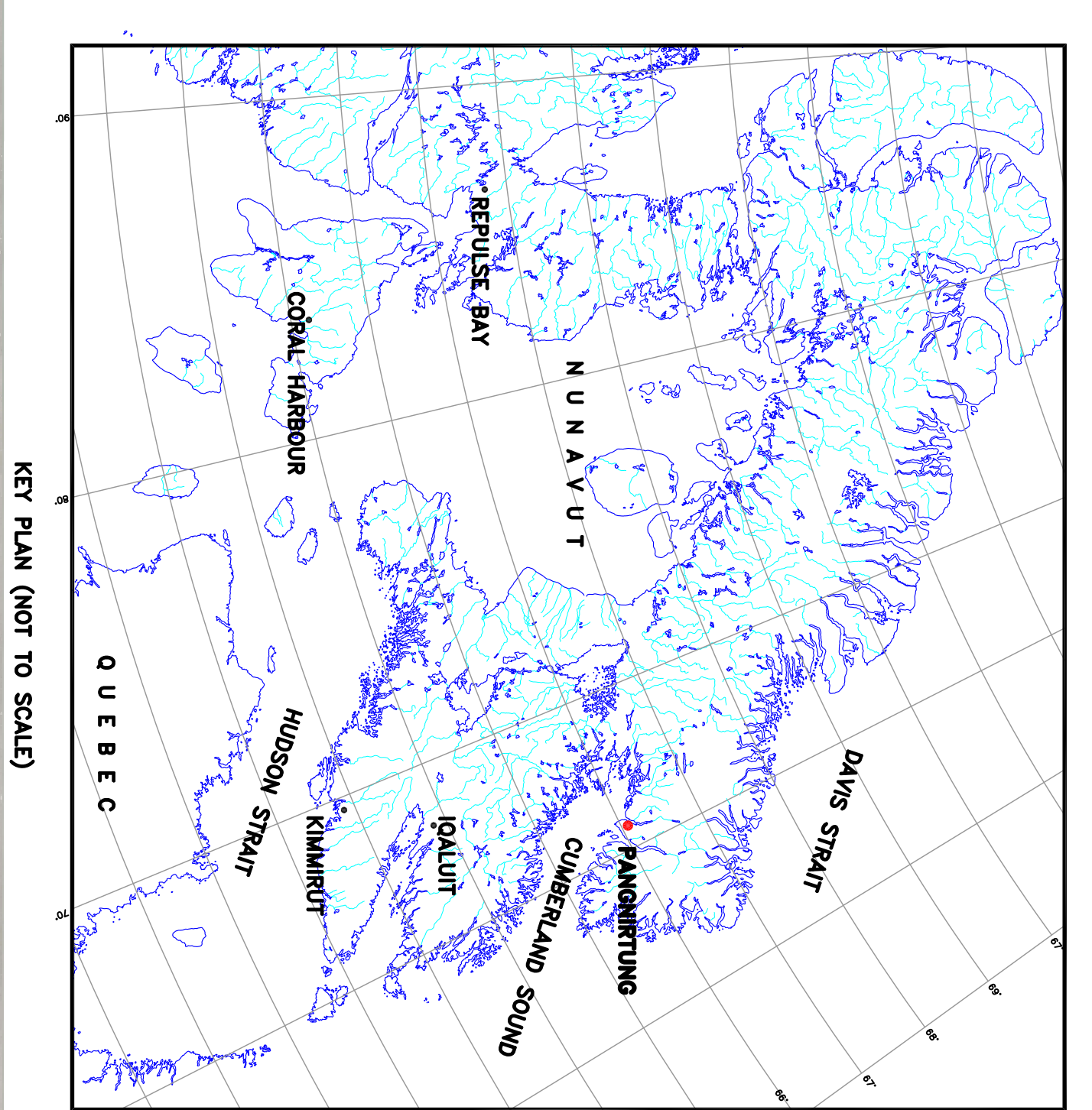

**BENCHMARK DATA**

HORIZONTAL: UTM ZONE 20 NORTH ARCTIC CSRS			
VERTICAL: HEIGHT ABOVE CHART DATUM			
BENCHMARK	NORTHING	EASTING	ELEVATION
BM2	7359092.91	377585.23	9.43



KEY PLAN (NOT TO SCALE)

 GOVERNMENT OF CANADA  
 GOVERNMENT OF NUNAVUT  
 FISHERIES AND OCEANS      PÊCHES ET OcéANS

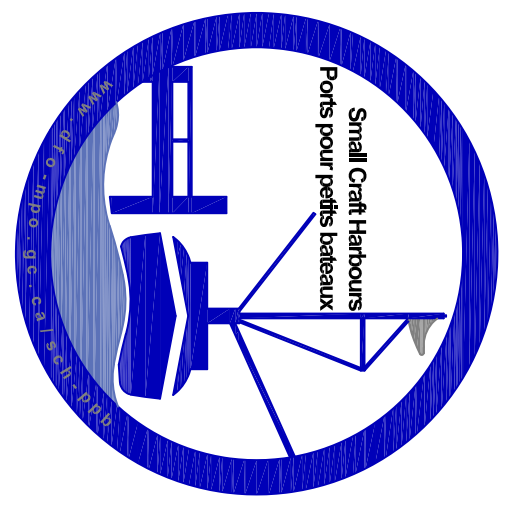

**SMALL CRAFT HARBOURS  
CENTRAL AND ARCTIC REGION**

**NOTES:**

1. DIMENSIONS AND ELEVATIONS ARE IN METRES UNLESS OTHERWISE STATED

SCOPE OF WORK:

1. DRAINAGE (SEE DWG C-2, C-3 & C-4):
  - 1.1. REALIGN AND RE-GRADE EXISTING DRAINAGE DITCH
  - 1.2. REPLACE EXISTING CULVERTS IN DRAINAGE DITCH AND UPGRADE ROAD OVER NEW DITCH
  - 1.3. REALIGN AND UPGRADE EXISTING HARBOR ACCESS ROAD AND UPPER ROAD
  - 1.4. DEMOLISH DECOMMISSIONED EXISTING CULVERTS AND BACKFILL PARKING AREA
  - 1.5. INSTALL EROSION CONTROL IN RE-GRADED DRAINAGE DITCH
2. BERM EXTENSION (SEE DWG C-5):
  - 2.1. CONSTRUCT BERM EXTENSION BETWEEN HARBOR ENTRANCE CHANNEL AND TIDAL DRAINAGE OUTLET
3. BREAKWATER UPGRADES, WHARF GRANULAR FILL UPGRADES & SHORE PROTECTION (SEE DWG C-6):
  - 3.1. SUPPLY AND INSTALL ARMOUR STONE IN AREAS INDICATED
  - 3.2. GRANULAR FILL ON FIXED WHARVES WHERE INDICATED
  - 3.3. SUPPLY AND INSTALL SHORE PROTECTION RIPRAP ON INNER BASIN SIDE SLOPE AS INDICATED

**LEGEND**

●	BENCHMARK
---	-----------

REVISIONS: 0 ISSUED FOR REVIEW NOV. 13, 2018

SCALE:	CLASS:
AS SHOWN	

**PROJECT:**  
**DRAINAGE IMPROVEMENTS  
& SHORE PROTECTION**

**SITE PLAN**

DESCRIPTION:	
DRAWN:	APPROVED:
SCH	SCH
DATE:	DATE:
NOVEMBER 2018	NOVEMBER 2018

LOCATION: PANGNIRTUNG, NUNAVUT

DRAWING NO.: C-1 OF 6      LOCATOR CODE: 5986



SMALL CRAFT HARBOURS  
 CENTRAL AND ARCTIC REGION



- NOTES:
1. DIMENSIONS AND ELEVATIONS ARE IN METRES UNLESS OTHERWISE STATED
  2. TYPICAL TIDAL RANGE - EL. 0.0M TO 7.4M

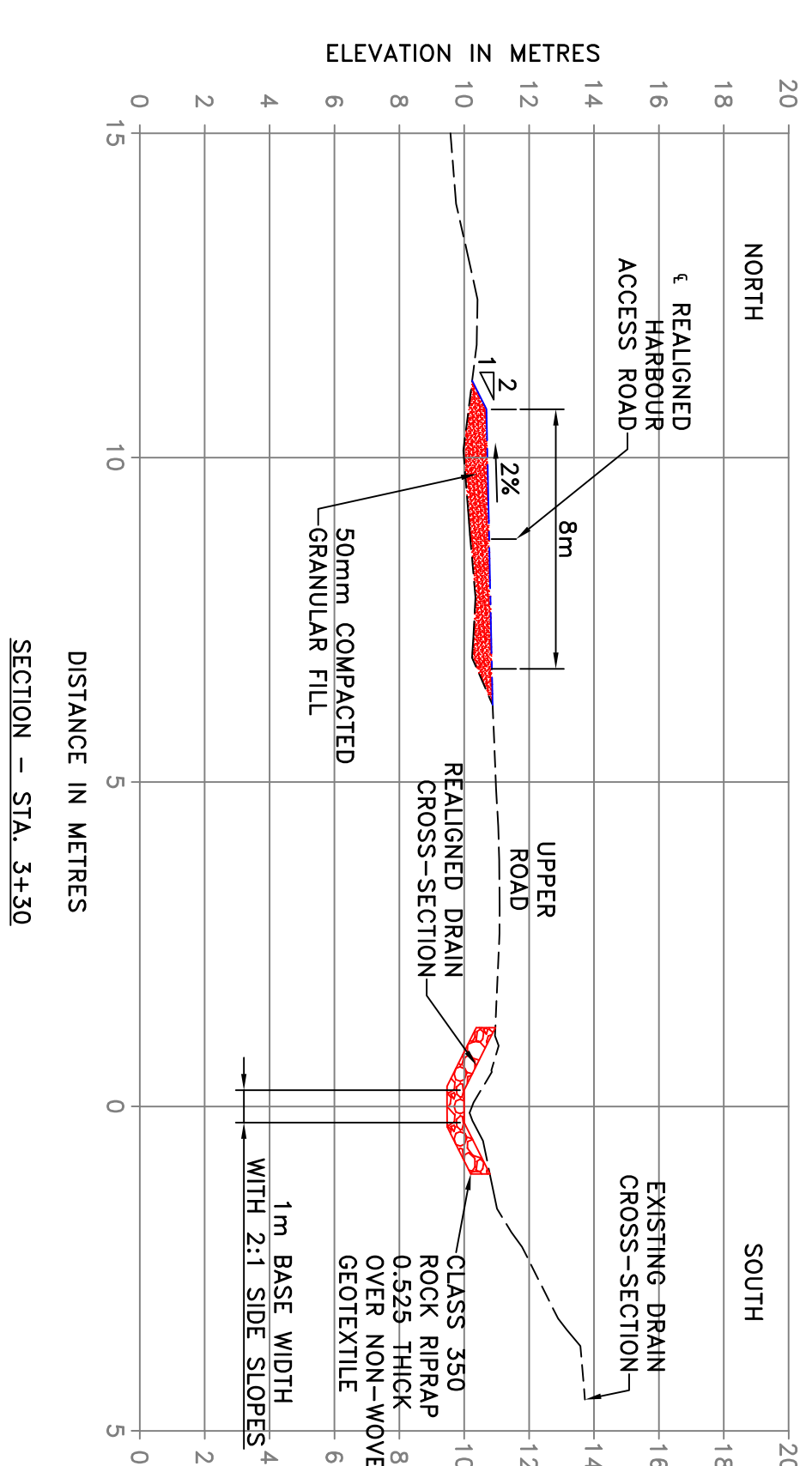
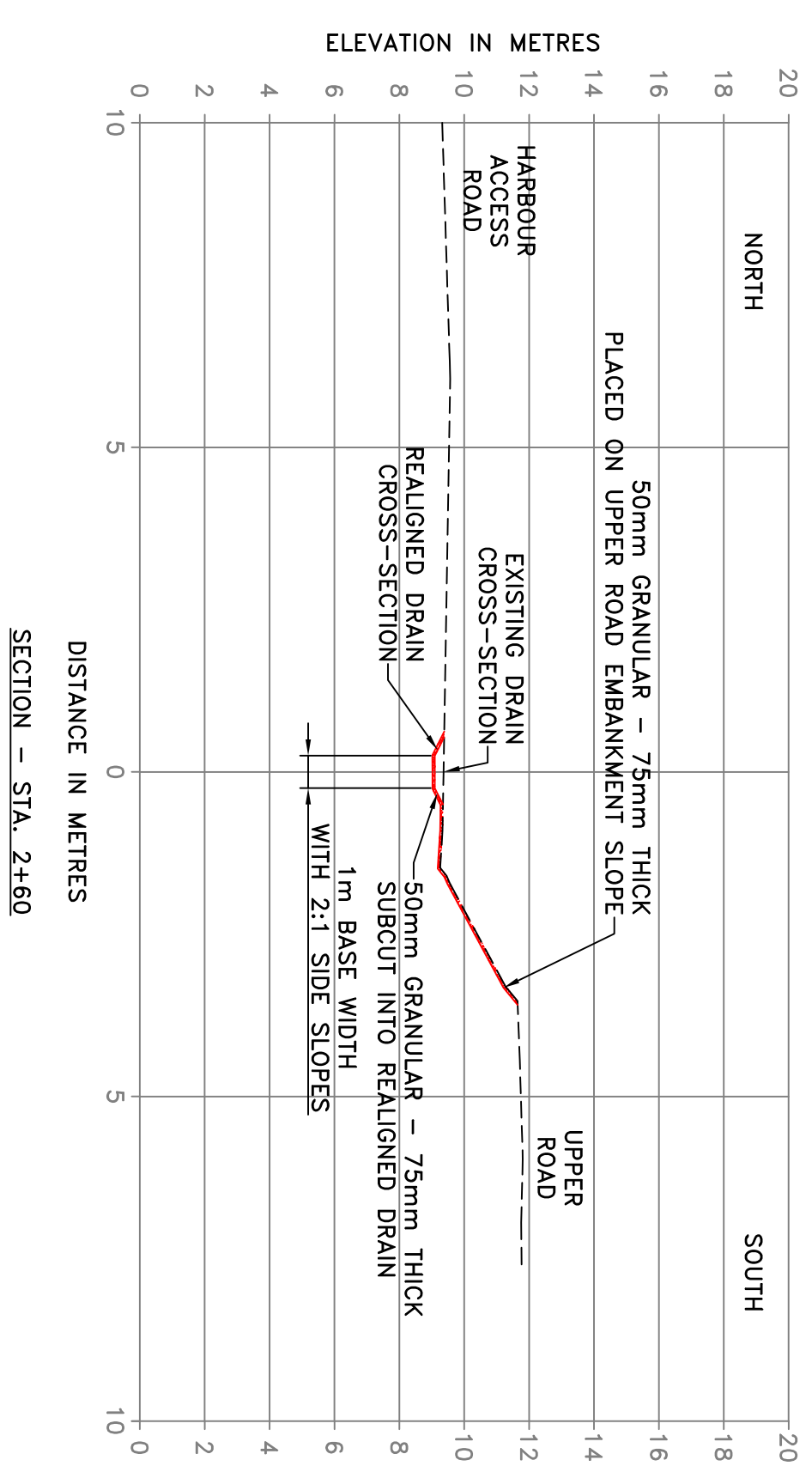
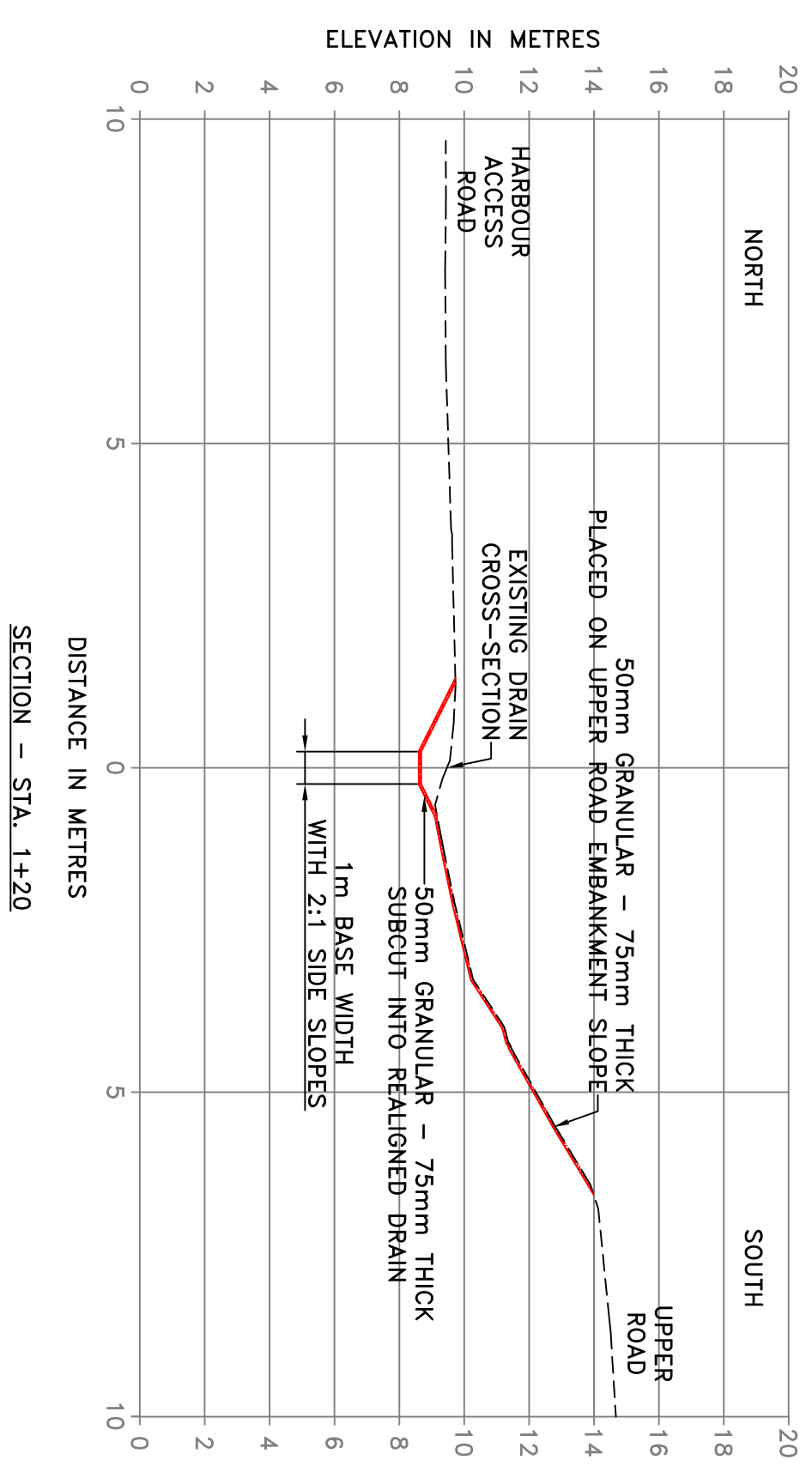
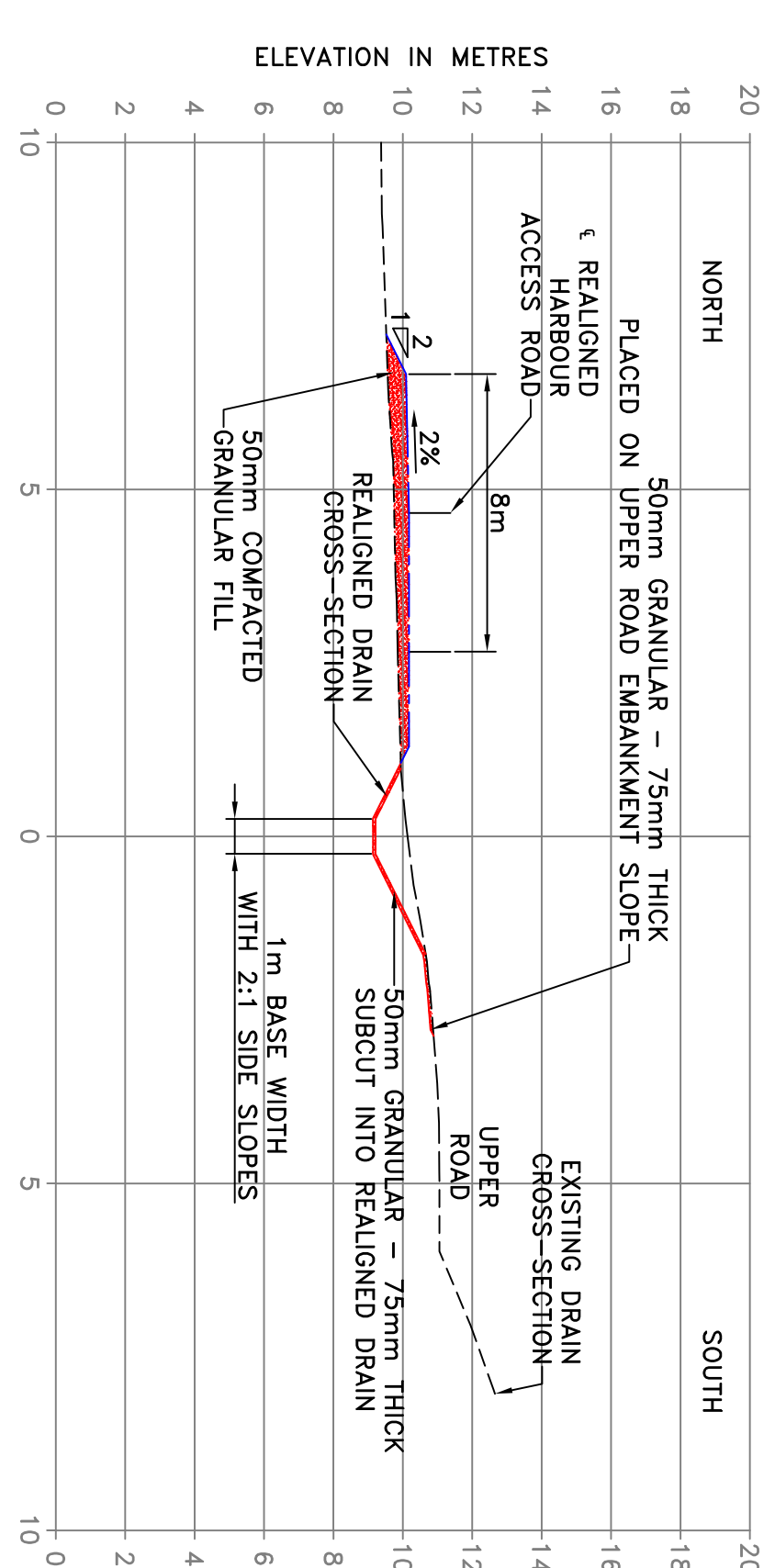
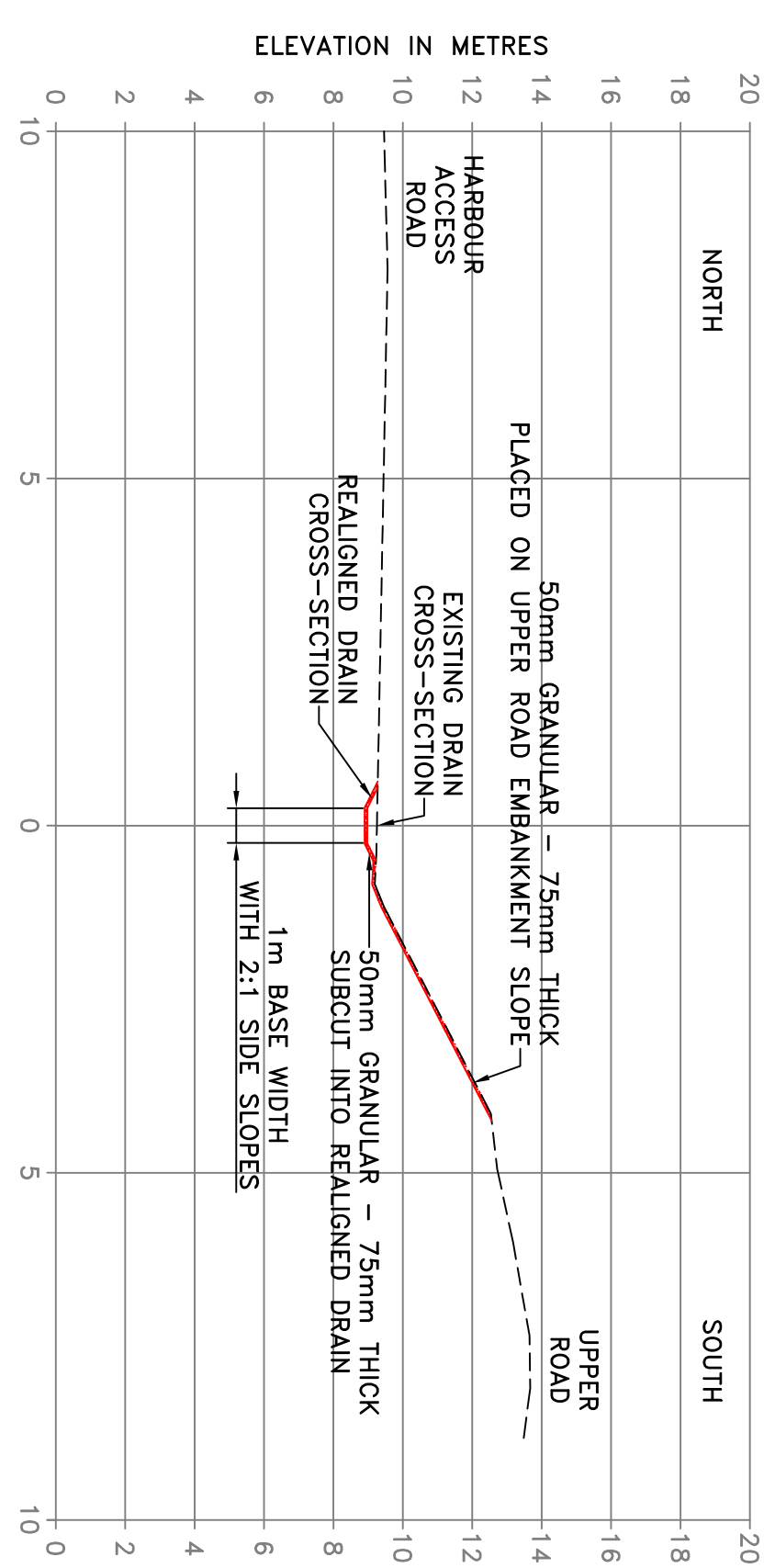
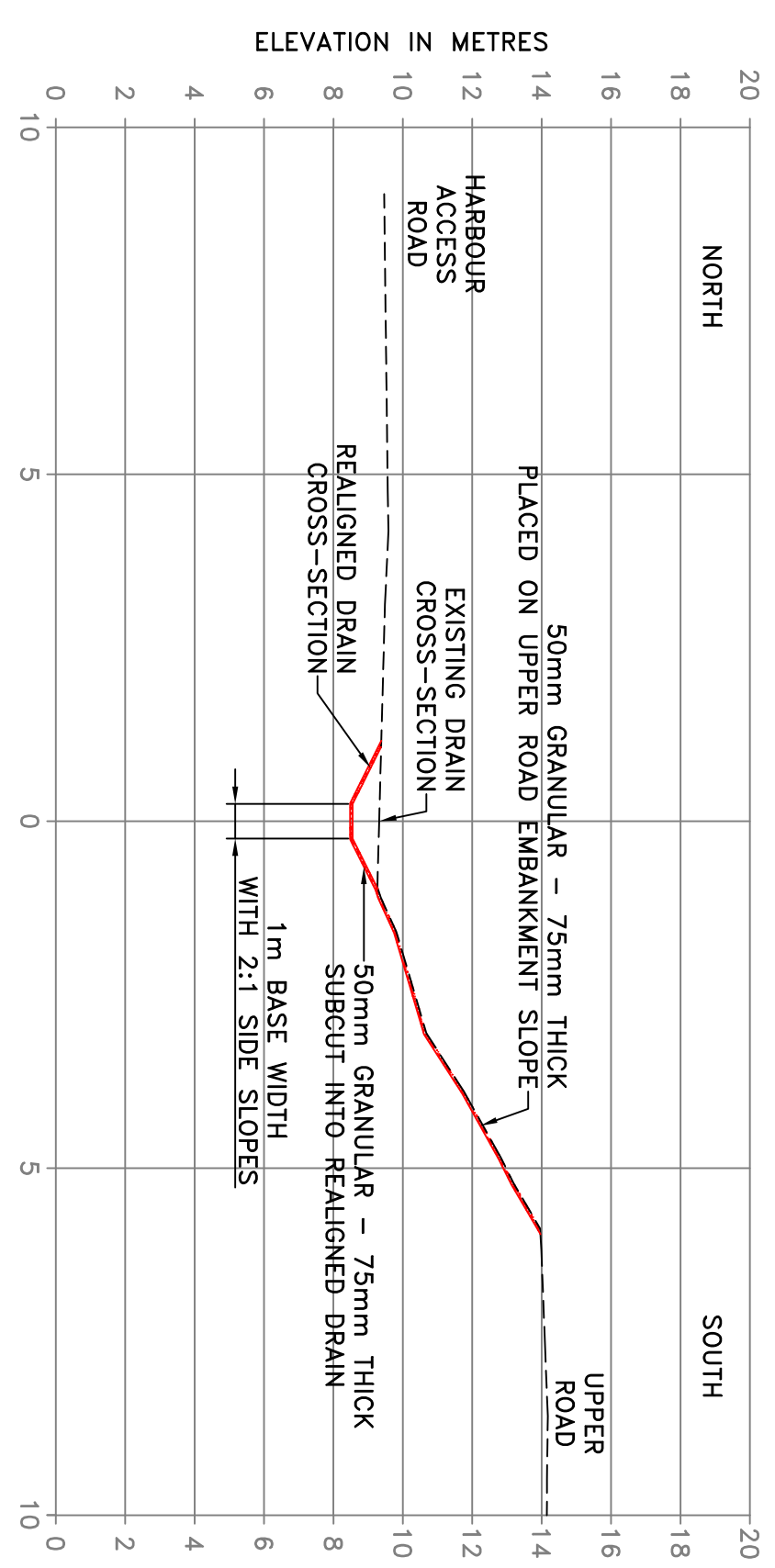
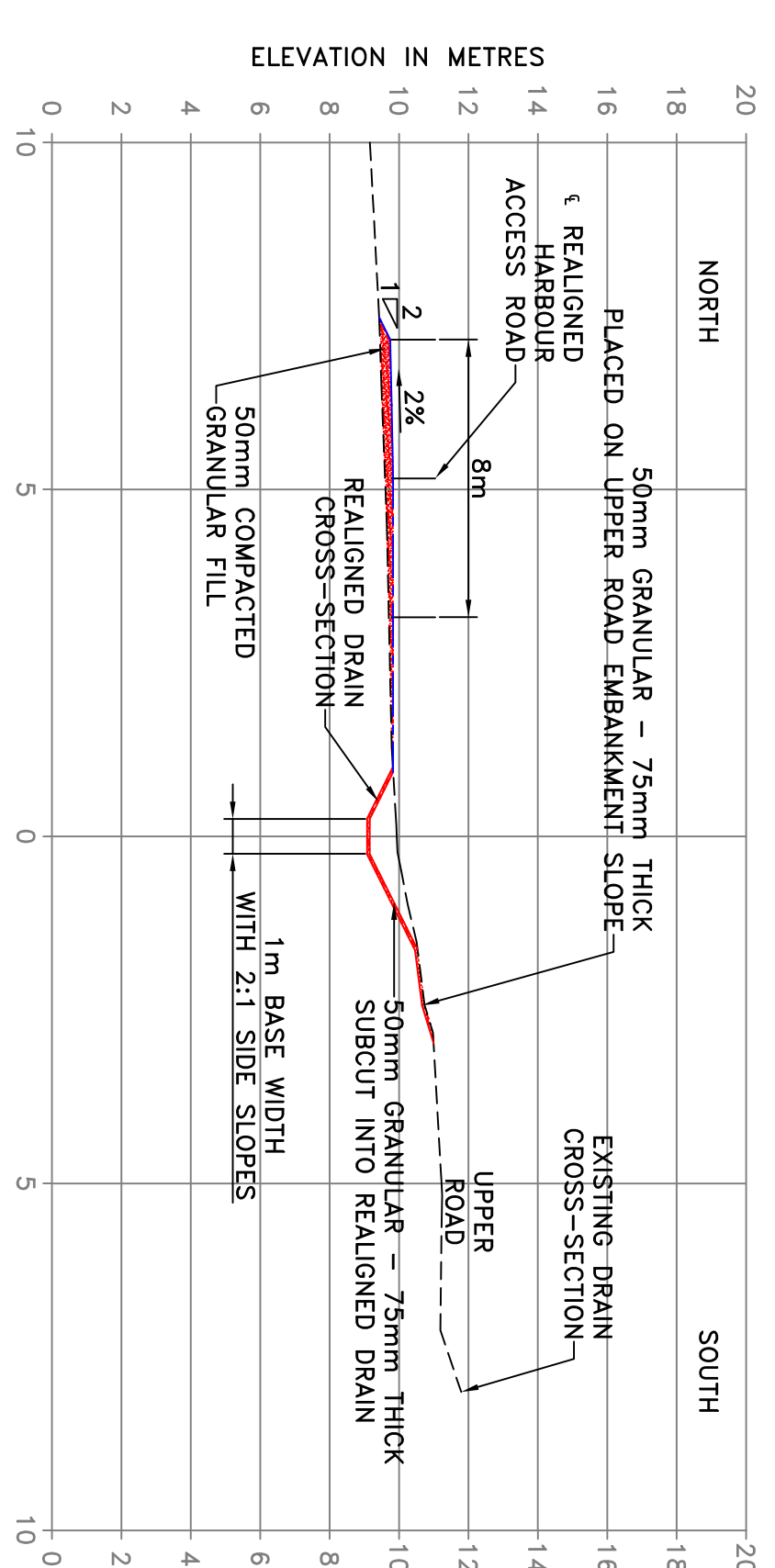
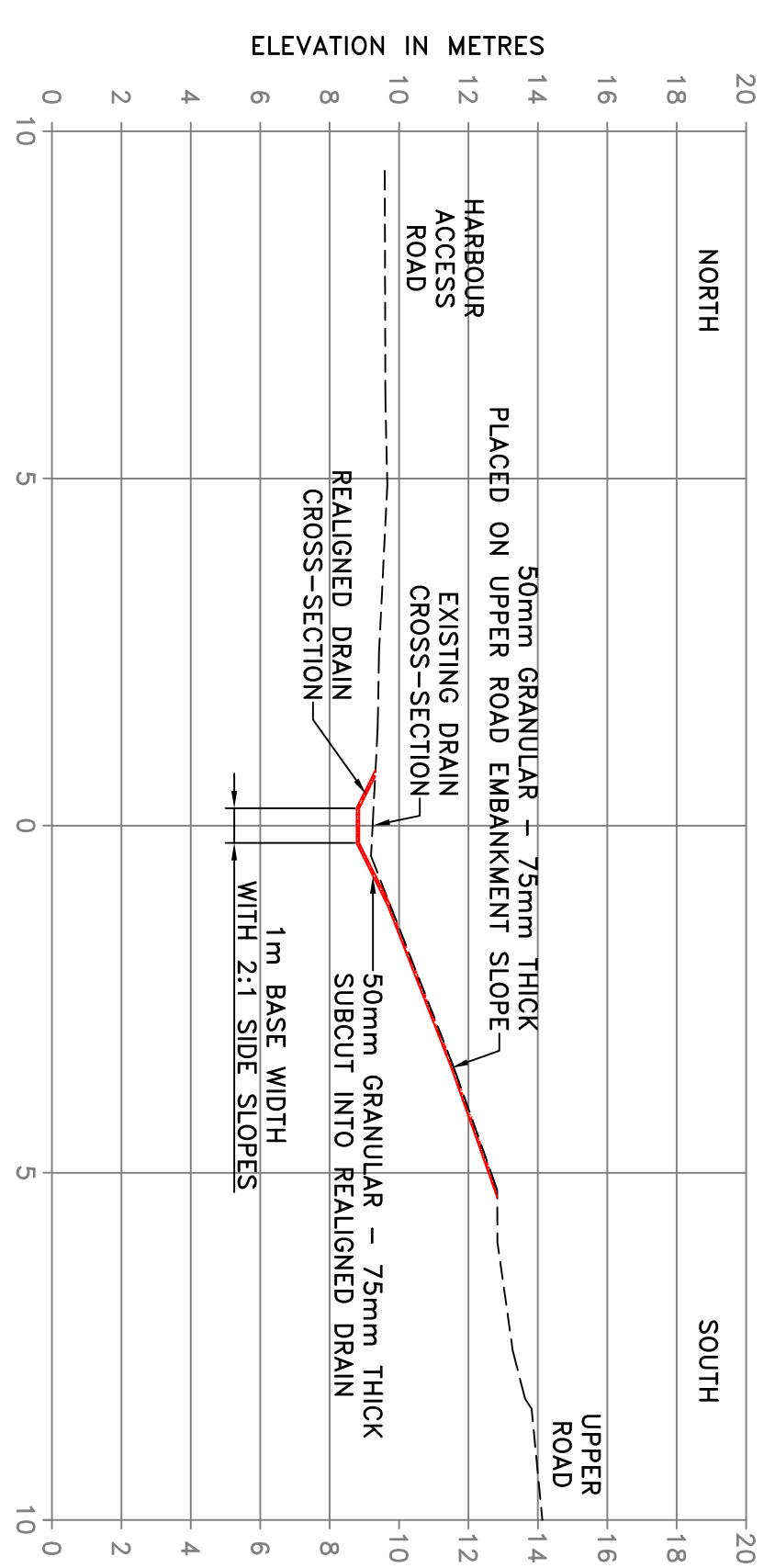
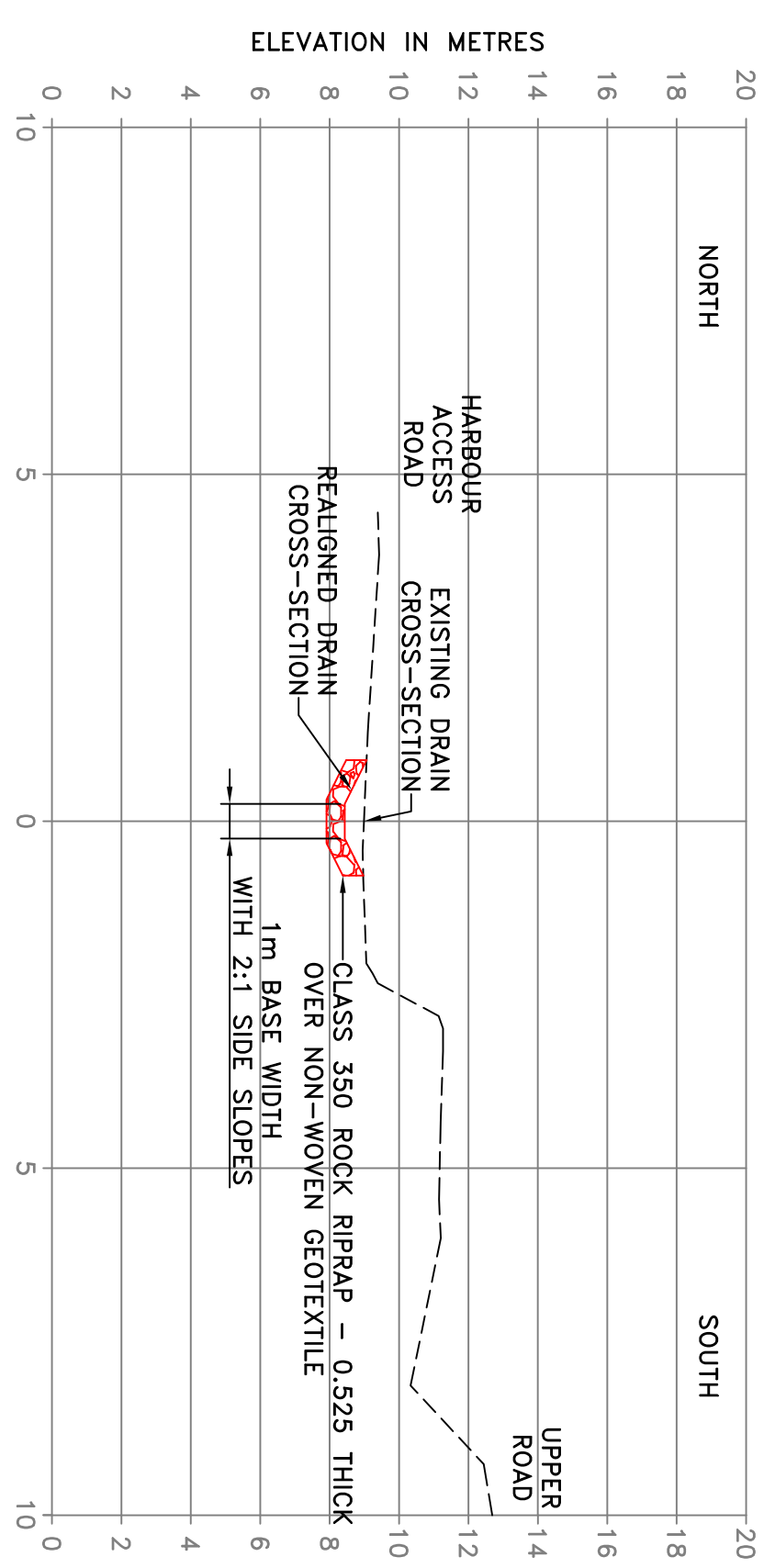

TYPICAL SECTIONS - REALIGNED DRAIN  
SCALE = 1:200

DESCRIPTION:

SECTIONS  
REALIGNED DRAIN

DRAWN:	SCH	APPROVED:	SCH
DATE:	NOVEMBER 2018	DATE:	NOVEMBER 2018

LOCATION:

PANGNIIRTUNG, NUNAVUT

PROJECT:

AS SHOWN

SCALE:

CLASS:

REVISIONS:	DATE:
0 ISSUED FOR REVIEW	NOV. 13, 2018

SMALL CRAFT HARBOURS  
CENTRAL AND ARCTIC REGION



- NOTES:
1. DIMENSIONS AND ELEVATIONS ARE IN METRES UNLESS OTHERWISE STATED
  2. TYPICAL TIDAL RANGE - EL. 0.0M TO 7.4M

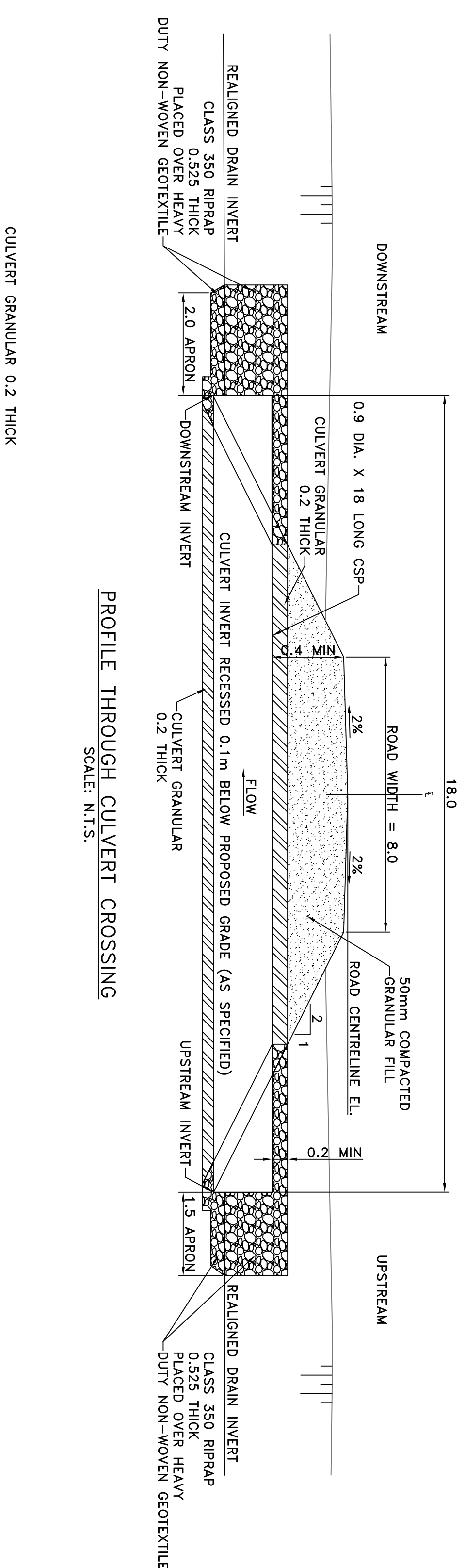

PROFILE THROUGH CULVERT CROSSING  
SCALE: N.T.S.

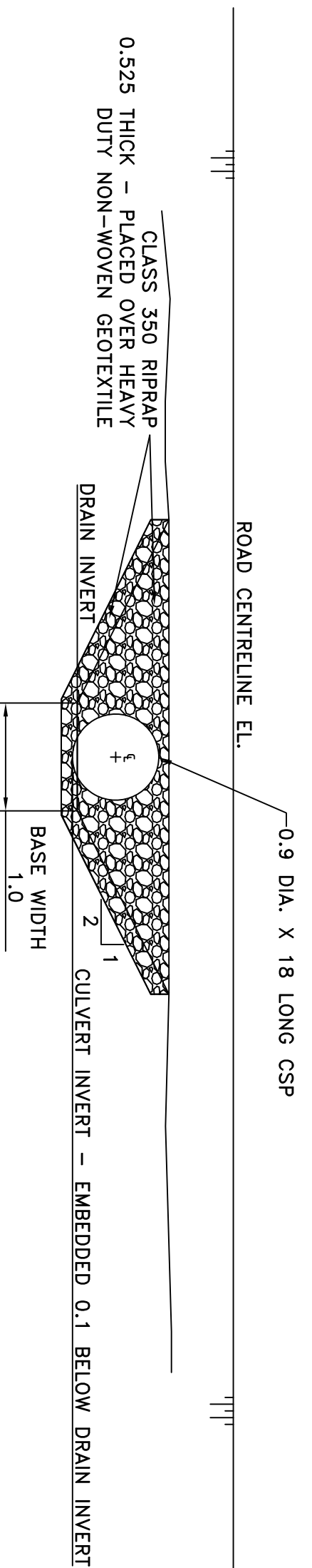

SECTION UPSTREAM/DOWNSTREAM OF CULVERT CROSSING  
SCALE: N.T.S.

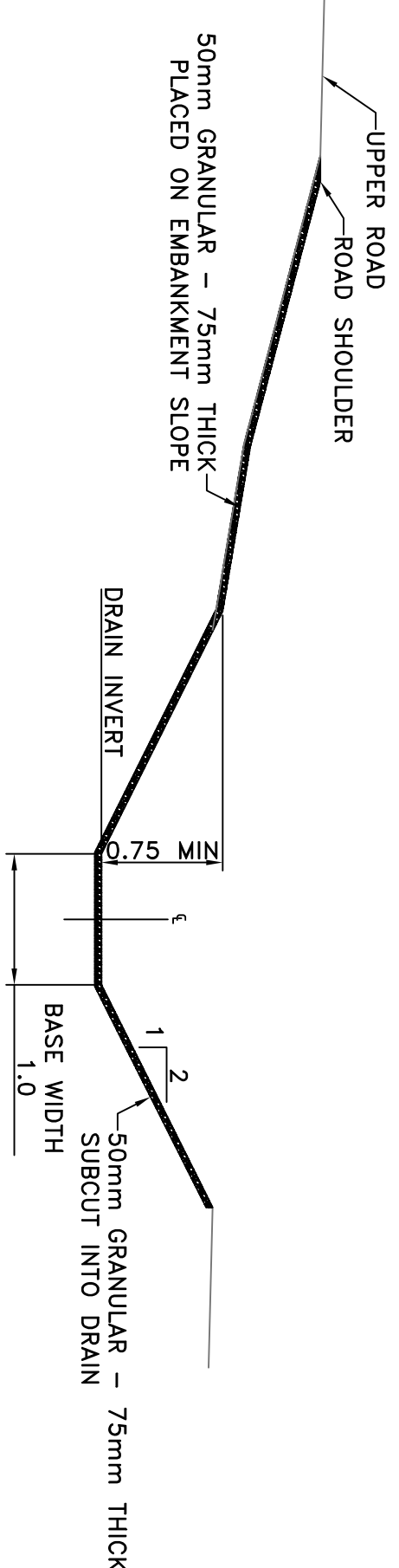

REALIGNED DRAIN SECTION - TYPICAL DETAIL  
SCALE: N.T.S.

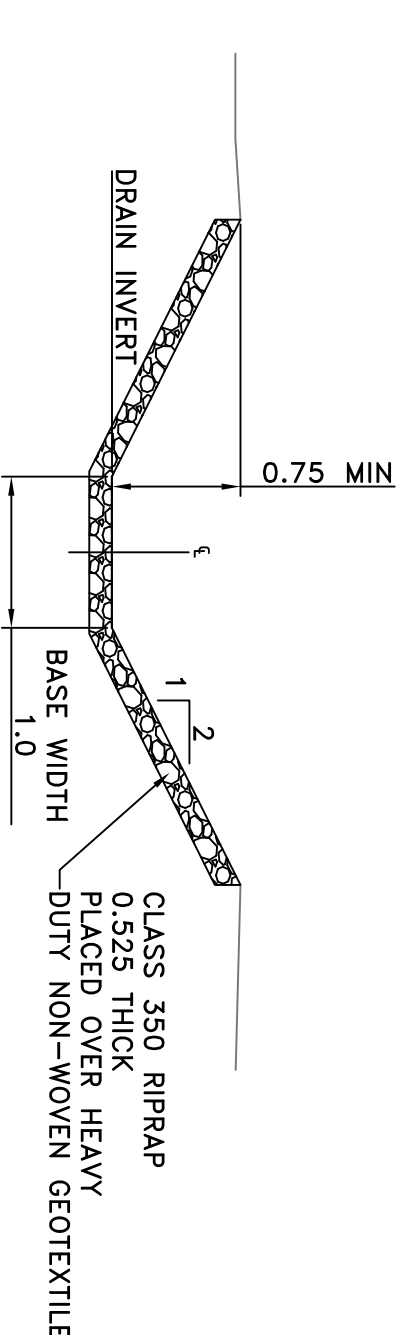

REALIGNED DRAIN SECTION - ROCK RIPRAP DETAIL  
SCALE: N.T.S.

NOTES:

- 1) CULVERT SUPPLY
- 1) ALL CULVERTS SHALL BE 2mm THICK WALL ALUMINIZED STEEL TYPE 2 CORRUGATED STEEL PIPE WITH 68mm BY 13mm CORRUGATED PROFILE.
- 2) THE CULVERT ENDS SHALL BE RE-CORRUGATED WITH 68mm BY 13mm ANNUAL PROFILE FOR A MINIMUM LENGTH OF 0.3m TO ACCEPT STANDARD COUPLERS.
- 3) CULVERT SECTION LENGTHS SHALL HAVE MINIMUM 6m LENGTH AND A MAXIMUM 8m LENGTH.
- 4) CULVERT SECTION LENGTHS SHALL BE LIMITED TO 12m.
- 5) CULVERT COUPLERS SHALL BE USED FOR ALL CULVERT COUPLERS. ALL COUPLERS TO BE 2mm THICKNESS WITH MINIMUM LENGTH OF 0.6m. THE COUPLER FASTENERS SHALL CONSIST OF A ROLLED OR FORMED ANGLE, WELDED TO THE COUPLER. COUPLERS SHALL HAVE AT LEAST FIVE 12mm DIA. GALVANIZED BOLTS C/W NUTS PER COUPLER.

- 1) CULVERT FOUNDATION
- 1) THE CULVERT FOUNDATION MEANS THE NATURAL SOIL, UNDERLYING THE EXCAVATION, UPON WHICH THE CULVERT BEING ON THE CULVERT IS TO BE PLACED.
- 2) CULVERT FOUNDATION SHALL BE REPAIRED AND COMPACTED TO THE STATED GRADUINE AND FOR A WIDTH SUFFICIENT TO PERMIT COMPACTION OF THE BEDDING UNDER THE CULVERT HAUNCHES. BED EXCAVATION TO HAVE A MINIMUM WIDTH OF 0.5 m FROM OUTSIDE EDGE OF CULVERT.
- 3) UNSUITABLE MATERIAL FROM BELOW THE STATED GRADUINE SHALL BE REMOVED TO AN APPROVED DEPTH AND REPLACED WITH SUITABLE BEDDING AND SUITABLE GEOTEXTILE IF REQUIRED, TO PROVIDE UNIFORM CONTINUOUS SUPPORT.

- 1) CULVERT PLACEMENT
- 1) CULVERT SECTIONS SHALL BE PLACED AT THE LOCATION, GRADE AND ALIGNMENT AS INDICATED ON THE PLAN AND THE CULVERT TABLE
- 2) CULVERT SECTIONS SHALL BE PLACED SO THAT THE COUPLER CORRUGATIONS SHALL PROPERLY ENGAGE PIPE CORRUGATIONS WITH THE MINIMUM GAP BETWEEN SECTION ENDS. COUPLER BOLTS SHALL BE FULLY TIGHTENED.

- 1) CULVERT GRANULAR - BEDDING
- 1) THE CULVERT BEDDING MEANS A LAYER OF SELECTED MATERIAL, GENERALLY CULVERT GRAVEL, CONSTRUCTED IN THE CULVERT FOUNDATION SO AS TO UNIFORMLY SUPPORT THE CULVERT.
- 2) CULVERT BEDDING SHALL BE PLACED IN UNIFORM LAYERS OF 150 mm TO 200 mm. THE SHALE CONTENT SHALL NOT EXCEED 25% BY WEIGHT OF THE PARTICLES RETAINED ON A 4.75 mm SIEVE. THE CULVERT GRAVEL SHALL GENERALLY MEET THE FOLLOWING GRADATION REQUIREMENTS:

PASSING 4.75 mm	25 - 100%
PASSING 75 µm	15 - 40%
PASSING 425 µm	15 - 100%
PASSING 75 µm	15 - 100%
PASSING 425 µm	15 - 100%

- 1) CULVERT GRANULAR - BACKFILLING - BELOW SPRINGLINE
- 1) MATERIAL UNDER SPRINGLINE SHALL BE PLACED IN UNIFORM LAYERS OF 150 mm TO 200 mm ON BOTH SIDES OF THE PIPE AND COMPACTED. THE MATERIAL UNDER THE HAUNCHES MUST BE IN FIRM CONTACT WITH THE ENTIRE BOTTOM SURFACE OF THE STRUCTURE. BACKFILL AND COMPACTION UNDER HAUNCHES IS A MANUAL JOB, CONSISTING OF SHOVEL PLACEMENT, TAMPER RAMMER OR HAND HELD PACKERS.
- 2) COMPACTION TO SPRINGLINE - AFTER THE HAUNCH AREA HAS BEEN BACKFILLED AND COMPACTED, ADDITIONAL BEDDING MATERIAL SHALL BE PLACED ADJACENT TO THE PIPE HAUNCHES IN LIFTS NOT EXCEEDING 150 mm. EACH LIFT SHALL BE COMPACTED WITH A PLATE TYPE MECHANICAL COMPACTOR. BEDDING MATERIAL SHALL BE PLACED IN THIS MANNER UP TO THE LEVEL OF THE SPRINGLINE. BEDDING MATERIAL PLACED ABOVE THE SPRINGLINE SHALL BE PLACED AS DESCRIBED IN BACKFILL.

- 1) BACKFILL WILL MEAN CULVERT GRAVEL OR SELECTED MATERIAL USED FOR FILL ADJACENT TO AND OVER AN ASSEMBLED CULVERT. THE LEVEL OF BACKFILL ON BOTH SIDES OF THE CULVERT SHALL BE MAINTAINED APPROXIMATELY EQUAL AT ALL TIMES TO PREVENT DISTURBING THE CULVERT.
- 2) CULVERTS SHALL BE BACKFILLED IN UNIFORM LAYERS NOT EXCEEDING 150 mm AND SHALL BE COMPACTED TO A MINIMUM OF 92% ASTM STANDARD DRY DENSITY.
- 3) A MINIMUM OF 92% ASTM STANDARD DRY DENSITY SHALL BE MAINTAINED THROUGHOUT THE ENTIRE CONSTRUCTION TO A SUFFICIENT HEIGHT ABOVE THE TOP OF THE CULVERT SO THAT NORMAL GRADING EQUIPMENT CAN OPERATE WITHOUT DISTORTING THE CULVERT.

CHANNEL EXCAVATION

- 1) THE DRAIN MAY REQUIRE EXCAVATION UPSTREAM AND DOWNSTREAM TO PROVIDE A SMOOTH TRANSITION TO THE EXISTING CHANNEL.
- 2) THE DIMS OF THE CHANNEL TRANSITION SHALL BE AS INDICATED ON THE PLAN OR AS DIRECTED BY ENGINEERING REPRESENTATIVE

- 1) THE CLASS 350 RIPRAP WILL BE WELL-GRADED, ROUNDED, CLEAN FIELD STONE OR QUARRIED CRUSHED ROCK WITH THE FOLLOWING GRADATION: 100% < 350 mm, 50% > 200 mm AND 80% > 100 mm.
- 2) RIPRAP TO BE PLACED OVER ARMYTEC 230 NON-WOVEN GEOTEXTILE OR EQUIVALENT

- 1) THE 50mm GRANULAR FOR LINING THE DRAIN AND FACING THE ROAD EMBANKMENT SLOPE WILL BE WELL-GRADED, CRUSHED ROCK WITH THE FOLLOWING GRADATION: 100% < 50 mm, 50% > 25 mm AND 80% > 10 mm.

REVISIONS:	DATE:
0	NOV. 13, 2018
ISSUED FOR REVIEW	

SCALE:	CLASS:
AS SHOWN	

PROJECT: DRAINAGE IMPROVEMENTS & SHORE PROTECTION

DESCRIPTION: TYPICAL SECTIONS & CULVERT INSTALLATION DETAILS

DRAWN:	APPROVED:
SCH	SCH
DATE:	DATE:
NOVEMBER 2018	NOVEMBER 2018

LOCATION: PANGNIIRTUNG, NUNAVUT

DRAWING NO.: C-4 OF 6 LOCATOR CODE: 5986

SMALL CRAFT HARBOURS  
CENTRAL AND ARCTIC REGION

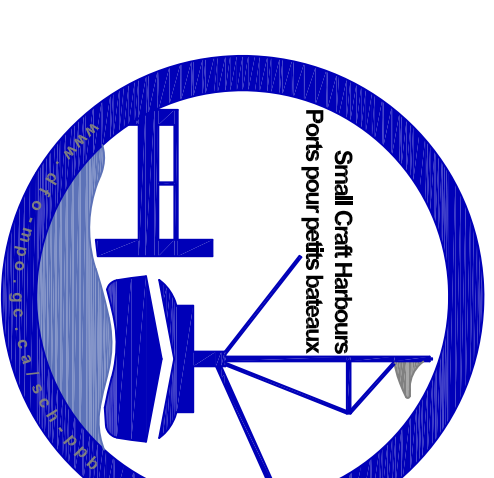

- NOTES:
- DIMENSIONS AND ELEVATIONS ARE IN METRES UNLESS OTHERWISE STATED
  - TYPICAL TIDAL RANGE - EL. 0.0M TO 7.4M

NEW BERM CONTROL POINTS			
POINT #	NORTHING	EASTING	ELEVATION
B1	7339541.605	377711.803	2.500
B2	7339483.073	377746.416	2.500

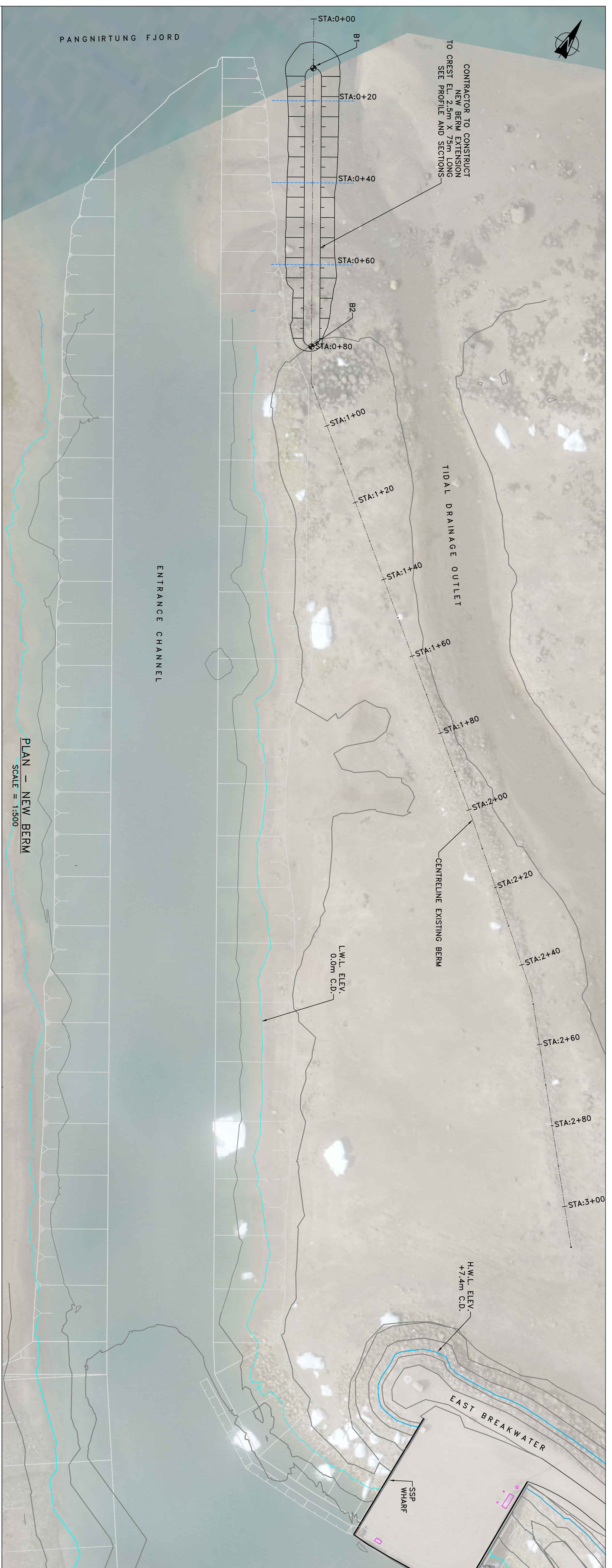

PLAN - NEW BERM  
SCALE = 1:500

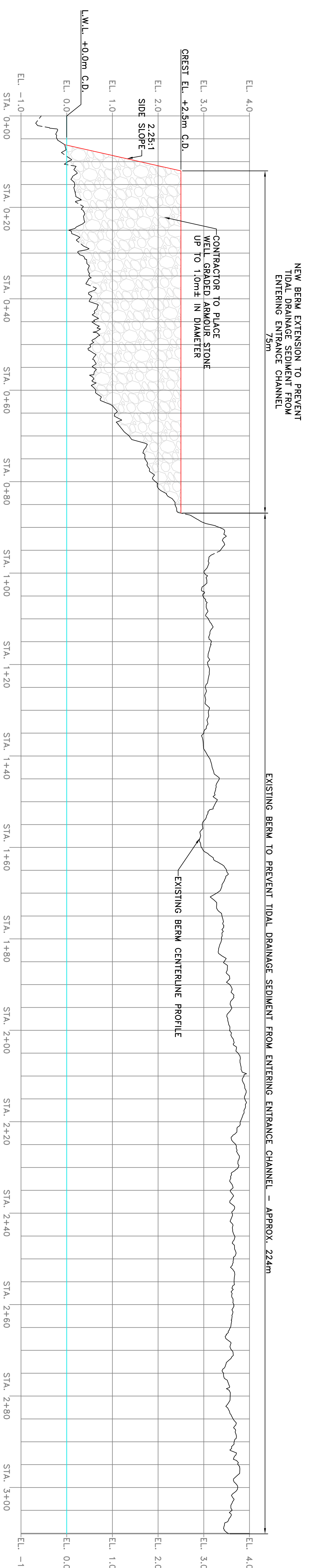

PROFILE - NEW BERM  
VERTICAL SCALE = 1:50  
HORIZONTAL SCALE = 1:500

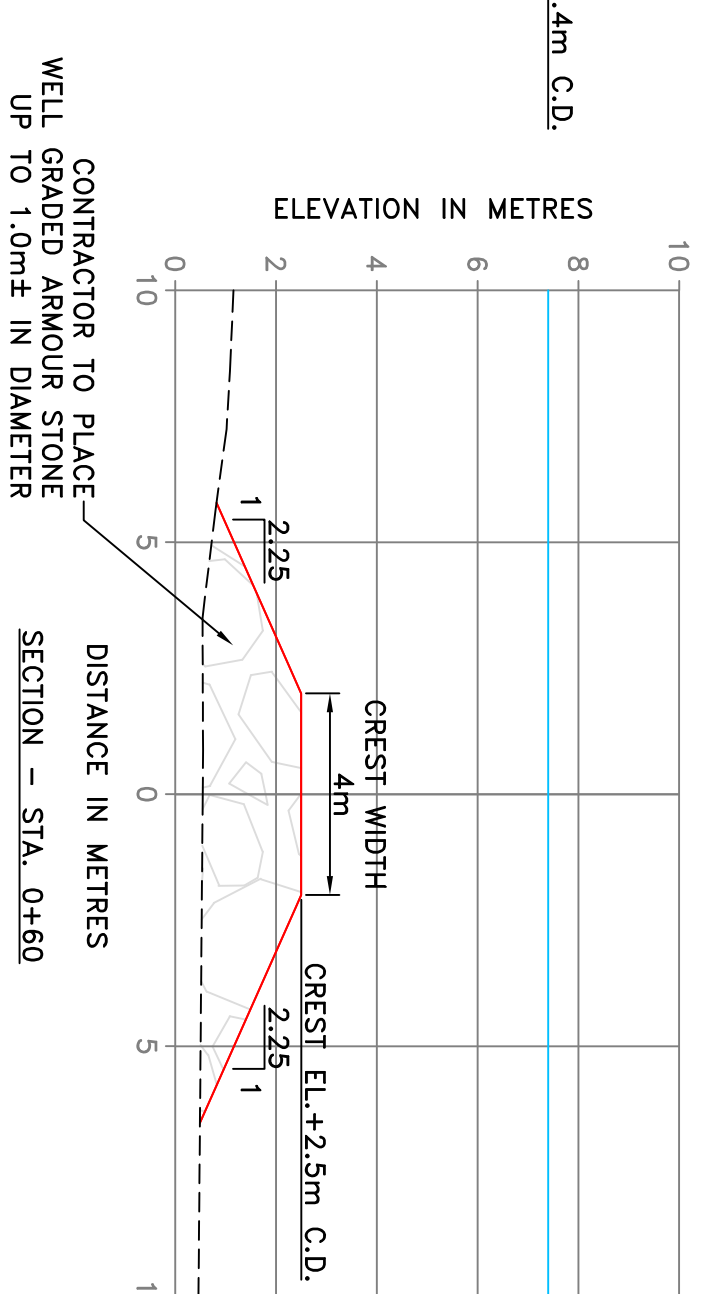
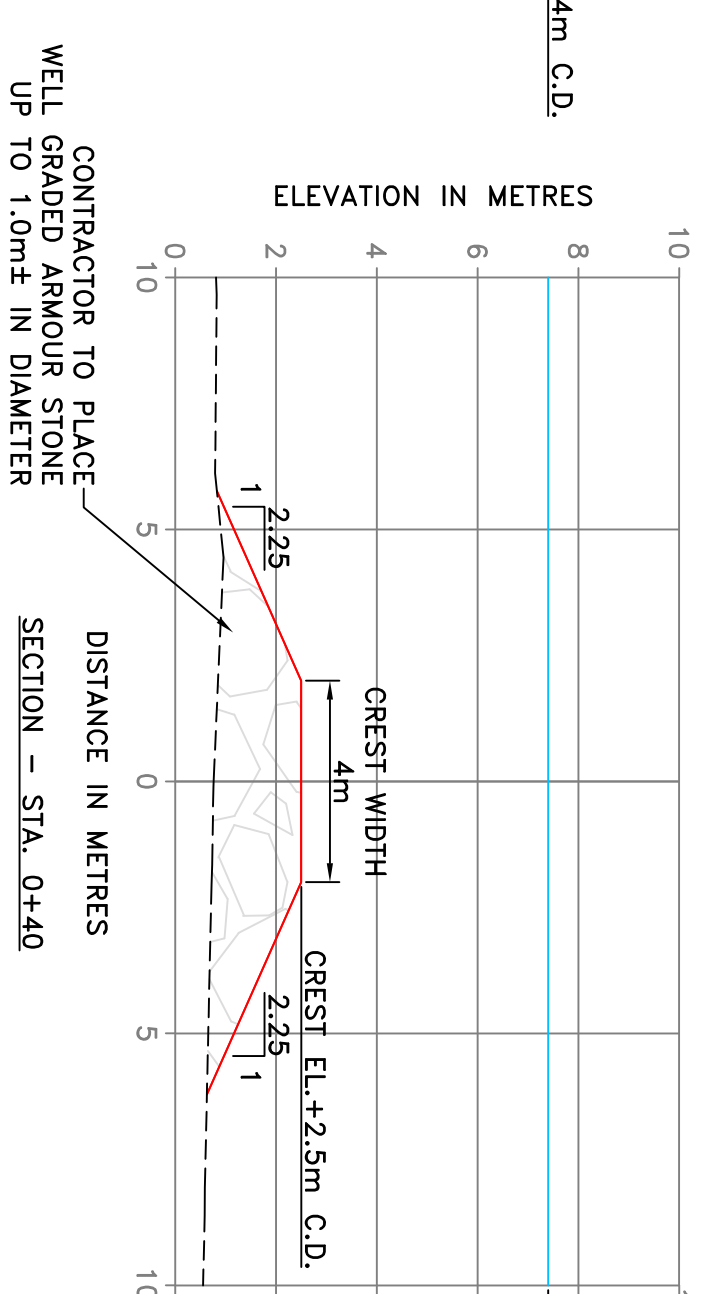
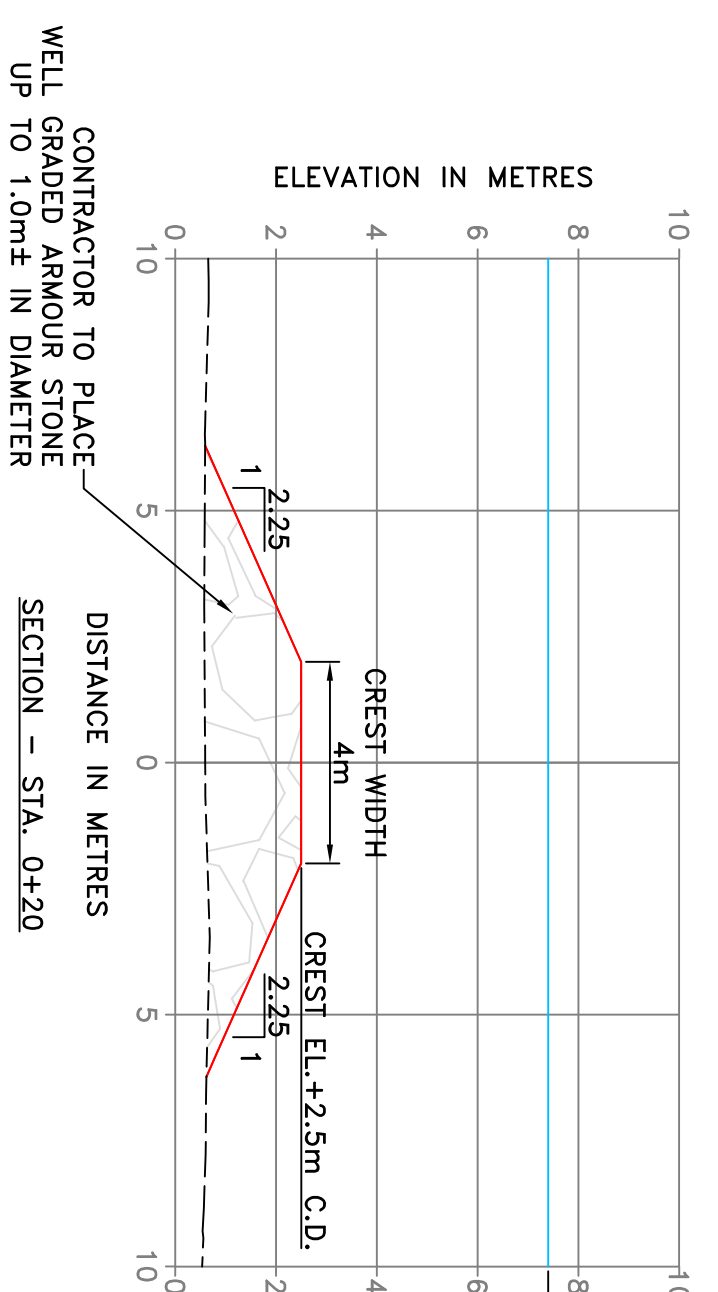

SECTIONS - NEW BERM  
SCALE = 1:150

DRAINAGE IMPROVEMENTS  
& SHORE PROTECTION

NEW BERM  
PLAN - PROFILE  
& SECTIONS

DATE:	NOVEMBER 2018	DATE:	NOVEMBER 2018
APPROVED:	SCH	APPROVED:	SCH

PANGNIRTUNG, NUNAVUT

DRAWING NO.: C-5 OF 6  
LOCATOR CODE: 5986

