



# **Spill Contingency Management Plan**

Angilak Property  
ATHA Energy Corp. and its wholly owned subsidiaries  
December 2025

## APPENDIX IV

### Safety Data Sheets

# Table of Contents

Antifreeze.....	1
Calcium Chloride.....	6
Chain Oil (Summer, Winter).....	12
Diesel Fuel.....	17
Drill Rod Heavy Grease.....	22
EPIC EP Moly Grease.....	26
Fuel System Treatment.....	32
Gasoline, Unleaded.....	37
Jet B Aviation Turbine Fuel.....	42
Marvelube WR2 Grease.....	47
Middle Distillate.....	53
Motor Oil (5W-30, 10W-30, 10W-40, 20W-50).....	60
Poly Drill 133-X.....	65
Poly Drill O.B.X.....	69
Portland Cement.....	71
Propane.....	77
Snowmobile Motor Oil.....	79
Supreme Fuel Injector G.L.A.F. & Conditioner.....	83
Tool Joint Compound.....	85
Traxon XL Synthetic Blend (75W-90, 80W-140).....	89
UNIVIS N 22.....	94
UNIVIS N 32.....	100
UNIVIS N 68.....	106
UNIREX LOTEMP Moly Grease.....	112



<b>WHMIS (Pictograms)</b>	<b>WHMIS (Classification)</b>	<b>Protective Clothing</b>	<b>TDG (pictograms)</b>
	<b>D-2A, D-2B</b>		

<b>Section 1. Chemical Product and Company Identification</b>	
<b>Product Name</b> <b>ANTIFREEZE</b>	<b>Code</b> W269
<b>Synonym</b> Universal Antifreeze, Radiator Antifreeze, Diesel Antifreeze, Petro-Canada Antifreeze-Coolant, Petro-Canada Heavy Duty Antifreeze-Coolant, Pre-Mix Antifreeze, Petro-Canada Premium Radiator Antifreeze, Diesel Engine Coolant.	<b>Validated on</b> 7/6/2004.
<b>Manufacturer</b> PETRO-CANADA P.O. Box 2844 Calgary, Alberta T2P 3E3	<b>In case of Emergency</b> Petro-Canada: 403-296-3000 Canutec Transportation: 613-996-6666 Poison Control Centre: Consult local telephone directory for emergency number(s).
<b>Material Uses</b> Used as an engine antifreeze coolant.	

<b>Section 2. Composition and Information on Ingredients</b>					
			<i>Exposure Limits (ACGIH)</i>		
<b>Name</b>	<b>CAS #</b>	<b>% (W/W)</b>	<b>TLV-TWA(8 h)</b>	<b>STEL</b>	<b>CEILING</b>
Ethylene glycol	107-21-1	≥90	Not established	Not established	100 mg/m <sup>3</sup> (aerosol)
Sodium tetraborate pentahydrate (Diesel Engine Coolant only)	12179-04-3	≤5	1 mg/m <sup>3</sup>	Not established	Not established
<b>Manufacturer Recommendation</b>	Not applicable				
<b>Other Exposure Limits</b>	Consult local, state, provincial or territory authorities for acceptable exposure limits.				

<b>Section 3. Hazards Identification.</b>	
<b>Potential Health Effects</b>	Contact with this product may cause eye irritation. Not expected to cause more than slight skin irritation. Inhalation of this product may cause respiratory tract irritation. Ingestion may be extremely hazardous. May cause teratogenicity/embryotoxicity. May cause damage to reproductive organs. For more information refer to Section 11 of this MSDS.

<b>Section 4. First Aid Measures</b>	
<b>Eye Contact</b>	IMMEDIATELY flush eyes with running water for at least 15 minutes, keeping eyelids open. Seek medical attention.
<b>Skin Contact</b>	Remove contaminated clothing - launder before reuse. Wash gently and thoroughly the contaminated skin with running water and non-abrasive soap. Seek medical attention.
<b>Inhalation</b>	Evacuate the victim to a safe area as soon as possible. If the victim is not breathing, perform artificial respiration. Allow the victim to rest in a well ventilated area. Seek medical attention.
<b>Ingestion</b>	DO NOT induce vomiting because of danger of aspirating liquid into lungs. Seek medical attention.
<b>Note to Physician</b>	Not available

<b>Section 5. Fire-fighting Measures</b>	
<b>Flammability</b>	May be combustible at high temperature.
<b>Flash Points</b>	Closed Cup: 116°C (241°F) (Tagliabue) Open Cup: 116°C (241°F) (Cleveland)
<b>Flammable Limits</b>	Lower: 3.2%, Upper: 15.3%
<b>Auto-Ignition Temperature</b>	413°C (775°F)

<b>Fire Hazards in Presence of Various Substances</b>	Low fire hazard. This material must be heated before ignition will occur.	<b>Explosion Hazards in Presence of Various Substances</b>	Do not cut, weld, heat, drill or pressurize empty container.
<b>Products of Combustion</b>	Carbon oxides (CO, CO <sub>2</sub> ), smoke and irritating vapours as products of incomplete combustion.		
<b>Fire Fighting Media and Instructions</b>	NAERG96, GUIDE 171, Substances (low to moderate hazard). If tank, rail car or tank truck is involved in a fire, ISOLATE for 800 meters (0.5 mile) in all directions; also, consider initial evacuation for 800 meters (0.5 mile) in all directions. Shut off fuel to fire if it is possible to do so without hazard. If this is impossible, withdraw from area and let fire burn out under controlled conditions. Withdraw immediately in case of rising sound from venting safety device or any discoloration of tank due to fire. Cool containing vessels with water spray in order to prevent pressure build-up, autoignition or explosion. SMALL FIRE: use DRY chemicals, foam, water spray or CO <sub>2</sub> . LARGE FIRE: use water spray, fog or foam. For small outdoor fires, portable fire extinguishers may be used, and self contained breathing apparatus (SCBA) may not be required. For all indoor fires and any significant outdoor fires, SCBA is required. Respiratory and eye protection are required for fire fighting personnel.		

### Section 6. Accidental Release Measures

<b>Material Release or Spill</b>	IN THE EVENT OF A LARGE SPILL CONSIDER THE FOLLOWING CONTROL MEASURES: Consult current National Emergency Response Guide Book (NAERG) for appropriate spill measures if necessary. Extinguish all ignition sources. Stop leak if safe to do so. Dike spilled material. Use appropriate inert absorbent material to absorb spilled product. Collect used absorbent for later disposal. Ventilate area. Ensure clean-up personnel wear appropriate personal protective equipment. Avoid breathing vapours or mists of material. Avoid contact with spilled material. Avoid contaminating sewers, streams, rivers and other water courses with spilled material. Notify appropriate authorities immediately.
----------------------------------	---

### Section 7. Handling and Storage

<b>Handling</b>	Avoid contact with any sources of ignition, flames, heat, and sparks. Avoid confined spaces and areas with poor ventilation. Avoid skin contact. Avoid eye contact. Avoid inhalation of product vapours or mists. Do not ingest this product. Wear proper personal protective equipment (See Section 8). Empty containers may contain product residue. Do not pressurize, cut, heat, or weld empty containers. Do not reuse containers without commercial cleaning and/or reconditioning. Personnel who handle this material should practice good personal hygiene during and after handling to help prevent accidental ingestion of this product. Properly dispose of contaminated leather articles including shoes that cannot be decontaminated.
<b>Storage</b>	Store in dry, cool, well-ventilated area. Store away from heat and sources of ignition. Keep container tightly closed. Store away from incompatible and reactive materials (See section 5 and 10).

### Section 8. Exposure Controls/Personal Protection

<b>Engineering Controls</b>	For normal application, special ventilation is not necessary. If user's operations generate vapours or mist, use ventilation to keep exposure to airborne contaminants below the exposure limit. Make-up air should always be supplied to balance air removed by exhaust ventilation. Ensure that eyewash station and safety shower are close to work-station.
<b>Personal Protection</b>	<b>- The selection of personal protective equipment varies, depending upon conditions of use.</b>
<b>Eyes</b>	Chemical splash goggles should be worn when handling this material.
<b>Body</b>	If this material may come into contact with the body during handling and use, we recommend wearing appropriate protective clothing to prevent contact with the skin. (Contact your PPE provider for more information).
<b>Respiratory</b>	A minimum of NIOSH-approved air-purifying respirator with a organic vapour cartridge or canister may be permissible under certain circumstances where airborne concentrations are expected to exceed exposure limits. Protection provided by air-purifying respirators is limited. Use a positive-pressure, air-supplied respirator if there is any potential for uncontrolled release, exposure levels are unknown, or any other circumstances where air-purifying respirators may not provide adequate protection.
<b>Hands</b>	If this material may come in contact with the hands during handling and use, we recommend wearing gloves of the following material(s): Neoprene, Polyvinyl chloride (PVC). Consult your PPE provider for breakthrough times and the specific glove that is best for you based on your use patterns.
<b>Feet</b>	Wear appropriate footwear to prevent product from coming in contact with feet and skin.

**Section 9. Physical and Chemical Properties**

<b>Physical State and Appearance</b>	Clear viscous liquid.	<b>Viscosity</b>	Not available
<b>Colour</b>	Green.	<b>Pour Point</b>	Not available
<b>Odour</b>	Odourless.	<b>Softening Point</b>	Not applicable.
<b>Odour Threshold</b>	Not available	<b>Dropping Point</b>	Not applicable.
<b>Boiling Point</b>	129 to 197°C (264 to 387°F)	<b>Penetration</b>	Not applicable.
<b>Density</b>	1.115 to 1.145 (Water = 1)	<b>Oil / Water Dist. Coefficient</b>	Not available
<b>Vapour Density</b>	2.1 (Air=1).	<b>Ionicity (in water)</b>	Not available
<b>Vapour Pressure</b>	0.06 mmHg @ 20°C (68°F).	<b>Dispersion Properties</b>	Not available
<b>Volatility</b>	0% (w/w)	<b>Solubility</b>	Soluble in water, methanol and diethyl ether.

**Section 10. Stability and Reactivity**

<b>Corrosivity</b>	Not available		
<b>Stability</b>	The product is stable.		
<b>Incompatible Substances / Conditions to Avoid</b>	Reactive with oxidizing agents, acids, alkalis, perchloric acid, phosphorus, silvered copper wires carrying DC current, aliphatic amines, isocyanates, chlorosulfonic acid and oluem.	<b>Hazardous Polymerization</b>	Will not occur under normal working conditions.
		<b>Decomposition Products</b>	May release CO <sub>x</sub> , smoke and irritating vapours when heated to decomposition.

**Section 11. Toxicological Information**

<b>Routes of Entry</b>	Skin contact, eye contact, inhalation and ingestion.		
<b>Acute Lethality</b>	<u>Ethylene glycol (107-21-1):</u> LD50: 4700 mg/kg (oral/rat). LD50: 9530 mg/kg (dermal/rabbit).  <u>Sodium tetraborate pentahydrate (12179-04-3):</u> LD50: 3200-3500 mg/kg (oral/rat) (Boric acid). [Sodium tetraborate pentahydrate]		
<b>Chronic or Other Toxic Effects</b>	<b>Dermal Route:</b> Short-term exposure is expected to cause only slight irritation, if any. <b>Inhalation Route:</b> Inhalation of this product may cause respiratory tract irritation. <b>Oral Route:</b> Extremely dangerous in case of ingestion. <b>Eye Irritation/Inflammation:</b> This product contains a component (at >= 1%) that can cause eye irritation. Therefore, this product is considered to be an eye irritant. <b>Immunotoxicity:</b> Not available <b>Skin Sensitization:</b> Contact with this product is not expected to cause skin sensitization, based upon the available data and the known hazards of the components. <b>Respiratory Tract Sensitization:</b> Contact with this product is not expected to cause respiratory tract sensitization, based upon the available data and the known hazards of the components. <b>Mutagenic:</b> This product is not known to contain any components at >= 0.1% that have been shown to cause mutagenicity. Therefore, based upon the available data and the known hazards of the components, this product is not expected to be a mutagen. <b>Reproductive Toxicity:</b> Borates are possible reproductive toxins based upon available animal ingestion studies in several species. These studies usually involved high doses, over prolonged periods of time. A human study following occupational exposure to borate by inhalation concluded that, no adverse effects to reproduction were found in this population, under the conditions of this study. <b>Teratogenicity/Embryotoxicity:</b> This product contains a component(s) at >= 0.1% that has been shown to cause teratogenicity and/or embryotoxicity in laboratory tests. Therefore, this product is considered to be a teratogen/embryotoxin (Ethylene glycol).		

Carcinogenicity (ACGIH):	ACGIH A4: not classifiable as a human carcinogen (Ethylene glycol). This product is not known to contain any chemicals at reportable quantities that are listed as Group A1, A2, or A3 carcinogens by ACGIH.
Carcinogenicity (IARC):	This product is not known to contain any chemicals at reportable quantities that are listed as Group 1, 2A, or 2B carcinogens by IARC.
Carcinogenicity (NTP):	This product is not known to contain any chemicals at reportable quantities that are listed as carcinogens by NTP.
Carcinogenicity (IRIS):	This product is not known to contain any chemicals at reportable quantities that are listed as carcinogens by IRIS.
Carcinogenicity (OSHA):	This product is not known to contain any chemicals at reportable quantities that are listed as carcinogens by OSHA.
<b>Other Considerations</b>	The substance may be toxic to kidneys and liver. Repeated or prolonged exposure to the substance can produce target organs damage. Repeated exposure to a highly toxic material may produce general deterioration of health by an accumulation in one or many human organs.

**Section 12. Ecological Information**

<b>Environmental Fate</b>	Not available	<b>Persistence/ Bioaccumulation Potential</b>	Not available
<b>BOD5 and COD</b>	Not available	<b>Products of Biodegradation</b>	Not available
<b>Additional Remarks</b> No additional remark.			

**Section 13. Disposal Considerations**

<b>Waste Disposal</b>	Spent/ used/ waste product may meet the requirements of a hazardous waste. Consult your local or regional authorities. Ensure that waste management processes are in compliance with government requirements and local disposal regulations.
-----------------------	--

**Section 14. Transport Information**

<b>TDG Classification</b>	Not a hazardous material for transport according to the TDG Regulations. (Canada)	<b>Special Provisions for Transport</b>	Not applicable.
---------------------------	---	---	-----------------

**Section 15. Regulatory Information**

<b>Other Regulations</b>	All of the components of this product are on the Domestic Substances List (DSL), are considered to be on the DSL, or are exempt from the New Substance Notification (NSN) requirements.																						
	All components of this formulation are listed on the US EPA-TSCA Inventory.																						
	This product has been classified in accordance with the hazard criteria of the Controlled Products Regulations (CPR) and the MSDS contains all of the information required by the CPR.																						
	Please contact Product Safety for more information.																						
<b>DSD/DPD (Europe)</b>	Not evaluated.	<b>HCS (U.S.A.)</b>	CLASS: Target organ effects. CLASS: Irritating substance.																				
<b>ADR (Europe) (Pictograms)</b>	NOT EVALUATED FOR EUROPEAN TRANSPORT  NON ÉVALUÉ POUR LE TRANSPORT EUROPÉEN.	<b>DOT (U.S.A) (Pictograms)</b>																					
<b>HMIS (U.S.A.)</b>	<table border="1"> <tr> <td>Health Hazard</td> <td>2*</td> </tr> <tr> <td>Fire Hazard</td> <td>1</td> </tr> <tr> <td>Reactivity</td> <td>0</td> </tr> <tr> <td>Personal Protection</td> <td>H</td> </tr> </table>	Health Hazard	2*	Fire Hazard	1	Reactivity	0	Personal Protection	H	<b>NFPA (U.S.A.)</b>	<table border="1"> <tr> <td>Health</td> <td>2</td> <td>Fire Hazard</td> <td>1</td> </tr> <tr> <td></td> <td></td> <td>Reactivity</td> <td>0</td> </tr> <tr> <td></td> <td></td> <td>Specific hazard</td> <td></td> </tr> </table>	Health	2	Fire Hazard	1			Reactivity	0			Specific hazard	
Health Hazard	2*																						
Fire Hazard	1																						
Reactivity	0																						
Personal Protection	H																						
Health	2	Fire Hazard	1																				
		Reactivity	0																				
		Specific hazard																					
		<b>Rating</b>	0 Insignificant 1 Slight 2 Moderate 3 High 4 Extreme																				

**Section 16. Other Information**

**References** Available upon request.  
\* Marque de commerce de Petro-Canada - Trademark

**Glossary**

ACGIH - American Conference of Governmental Industrial Hygienists	IRIS - Integrated Risk Information System
ADR - Agreement on Dangerous goods by Road (Europe)	LD50/LC50 - Lethal Dose/Concentration kill 50%
ASTM - American Society for Testing and Materials	LDLo/LCLo - Lowest Published Lethal Dose/Concentration
BOD5 - Biological Oxygen Demand in 5 days	NAERG'96 - North American Emergency Response Guide Book (1996)
CAN/CGA B149.2 Propane Installation Code	NFPA - National Fire Prevention Association
CAS - Chemical Abstract Services	NIOSH - National Institute for Occupational Safety & Health
CEPA - Canadian Environmental Protection Act	NPRI - National Pollutant Release Inventory
CERCLA - Comprehensive Environmental Response, Compensation and Liability Act	NSNR - New Substances Notification Regulations (Canada)
CFR - Code of Federal Regulations	NTP - National Toxicology Program
CHIP - Chemicals Hazard Information and Packaging Approved Supply List	OSHA - Occupational Safety & Health Administration
COD5 - Chemical Oxygen Demand in 5 days	PEL - Permissible Exposure Limit
CPR - Controlled Products Regulations	RCRA - Resource Conservation and Recovery Act
DOT - Department of Transport	SARA - Superfund Amendments and Reorganization Act
DSCL - Dangerous Substances Classification and Labeling (Europe)	SD - Single Dose
DSD/DPD - Dangerous Substances or Dangerous Preparations Directives (Europe)	STEL - Short Term Exposure Limit (15 minutes)
DSL - Domestic Substance List	TDG - Transportation Dangerous Goods (Canada)
EEC/EU - European Economic Community/European Union	TDL0/TCL0 - Lowest Published Toxic Dose/Concentration
EINECS - European Inventory of Existing Commercial Chemical Substances	Tlm - Median Tolerance Limit
EPCRA - Emergency Planning and Community Right to Know Act	TLV-TWA - Threshold Limit Value-Time Weighted Average
FDA - Food and Drug Administration	TSCA - Toxic Substances Control Act
FIFRA - Federal Insecticide, Fungicide and Rodenticide Act	USEPA - United States Environmental Protection Agency
HCS - Hazardous Communication System	USP - United States Pharmacopoeia
HMIS - Hazardous Material Information System	WHMIS - Workplace Hazardous Material Information System
IARC - International Agency for Research on Cancer	

**For Copy of MSDS**

Internet: [www.petro-canada.ca/msds](http://www.petro-canada.ca/msds)

**Fuels & Solvents:**

Western Canada, Ontario & Central Canada, telephone: 1-800-668-0220; fax: 1-800-837-1228

Quebec & Eastern Canada, telephone: 514-640-8308; fax: 514-640-8385

For Product Safety Information: (905) 804-4752

Prepared by Product Safety - TLM on 7/6/2004.

Data entry by Product Safety - RS.

*To the best of our knowledge, the information contained herein is accurate. However, neither the above named supplier nor any of its subsidiaries assumes any liability whatsoever for the accuracy or completeness of the information contained herein. Final determination of suitability of any material is the sole responsibility of the user. All materials may present unknown hazards and should be used with caution. Although certain hazards are described herein, we cannot guarantee that these are the only hazards that exist.*

# MATERIAL SAFETY DATA SHEET

## CALCIUM CHLORIDE

### 1. CHEMICAL PRODUCT AND COMPANY IDENTIFICATION

**TRADE NAME:** CALCIUM CHLORIDE

**CHEMICAL CLASS:** Inorganic salts.

**APPLICATIONS:** Oil well drilling fluid additive. Oil well completion fluid additive. Weighting agent.

**EMERGENCY TELEPHONE:** 281-561-1600

**SUPPLIER:** Supplied by a Business Unit of  
M-I L.L.C.  
P.O. Box 42842, Houston, Texas 77242-2842  
See cover sheet for local supplier.

**TELEPHONE:** 281-561-1509

**FAX:** 281-561-7240

**CONTACT PERSON:** Sam Hoskin - Manager, Occupational Health

### 2. COMPOSITION, INFORMATION ON INGREDIENTS

INGREDIENT NAME:	CAS No.:	CONTENTS :	EPA RQ:	TPQ:
Calcium chloride	10043-52-4	60-100 %		

### 3. HAZARDS IDENTIFICATION

#### EMERGENCY OVERVIEW:

CAUTION! MAY CAUSE EYE, SKIN AND RESPIRATORY TRACT IRRITATION. Avoid contact with eyes, skin and clothing. Avoid breathing airborne product. Keep container closed. Use with adequate ventilation. Wash thoroughly after handling.

This product is a/an white powder. A nuisance dust. Dike and contain spills. Keep out of sewers and waterways. No significant immediate hazards for emergency response personnel are known.

#### ACUTE EFFECTS:

##### HEALTH HAZARDS, GENERAL:

Particulates may cause mechanical irritation to the eyes, nose, throat and lungs. Particulate inhalation may lead to pulmonary fibrosis, chronic bronchitis, emphysema and bronchial asthma. Dermatitis and asthma may result from short contact periods.

**INHALATION:** Irritating to the respiratory tract if inhaled.

**INGESTION:** Harmful if swallowed. May cause gastric distress, nausea and vomiting if ingested.

**SKIN:** Irritating to the skin.

**EYES:** Irritating to the eyes.

#### CHRONIC EFFECTS:

**CARCINOGENICITY:**

IARC: Not listed. OSHA: Not regulated. NTP: Not listed.

**ROUTE OF ENTRY:**

Inhalation. Skin and/or eye contact.

**TARGET ORGANS:**

Respiratory system, lungs. Skin. Eyes.

---

**4. FIRST AID MEASURES**

---

**GENERAL:**

Persons seeking medical attention should carry a copy of this MSDS with them.

**INHALATION:**

Move the exposed person to fresh air at once. Perform artificial respiration if breathing has stopped. Get medical attention.

**INGESTION:**

Drink a couple of glasses water or milk. Do not give victim anything to drink of he is unconscious. Get medical attention.

**SKIN:**

Wash skin thoroughly with soap and water. Remove contaminated clothing. Get medical attention if any discomfort continues.

**EYES:**

Promptly wash eyes with lots of water while lifting the eye lids. Continue to rinse for at least 15 minutes. Get medical attention if any discomfort continues.

---

**5. FIRE FIGHTING MEASURES**

---

**FLAMMABILITY LIMIT - LOWER(%):** N/D

**FLAMMABILITY LIMIT - UPPER(%):** N/D

**EXTINGUISHING MEDIA:**

Use extinguishing media appropriate for surrounding fire. Carbon dioxide (CO2). Dry chemicals. Foam. Water spray, fog or mist.

**SPECIAL FIRE FIGHTING PROCEDURES:**

No specific fire fighting procedure given.

**UNUSUAL FIRE & EXPLOSION HAZARDS:**

No unusual fire or explosion hazards noted.

**HAZARDOUS COMBUSTION PRODUCTS:**

This material is not combustible. No specific hazardous combustion products noted.

---

**6. ACCIDENTAL RELEASE MEASURES**

---

**PERSONAL PRECAUTIONS:**

Wear proper personal protective equipment (see MSDS Section 8).

**SPILL CLEAN-UP PROCEDURES:**

Avoid generating and spreading of dust. Shovel into dry containers. Cover and move the containers. Flush the area with water. Do not contaminate drainage or waterways. Repackage or recycle if possible.

## 7. HANDLING AND STORAGE

### HANDLING PRECAUTIONS:

Avoid handling causing generation of dust. Wear full protective clothing for prolonged exposure and/or high concentrations. Eye wash and emergency shower must be available at the work place. Wash hands often and change clothing when needed. Provide good ventilation. Mechanical ventilation or local exhaust ventilation is required.

### STORAGE PRECAUTIONS:

Store at moderate temperatures in dry, well ventilated area. Keep in original container.

## 8. EXPOSURE CONTROLS, PERSONAL PROTECTION

INGREDIENT NAME:	CAS No.:	OSHA PEL:		ACGIH TLV:		OTHER:		UNITS:
		TWA:	STEL:	TWA:	STEL:	TWA:	STEL:	
Calcium chloride	10043-52-4	5		3				mg/m3 resp.dus

### INGREDIENT COMMENTS:

No exposure limits noted for ingredient(s). Exposure limits are for Particulates Not Otherwise Classified (PNOC).

### PROTECTIVE EQUIPMENT:



### ENGINEERING CONTROLS:

Use appropriate engineering controls such as, exhaust ventilation and process enclosure, to reduce air contamination and keep worker exposure below the applicable limits.

**VENTILATION:** Supply natural or mechanical ventilation adequate to exhaust airborne product and keep exposures below the applicable limits.

**RESPIRATORS:** Use at least a NIOSH-approved N95 half-mask disposable or reuseable particulate respirator. In work environments containing oil mist/aerosol use at least a NIOSH-approved P95 half-mask disposable or reuseable particulate respirator.

### PROTECTIVE GLOVES:

Use suitable protective gloves if risk of skin contact.

### EYE PROTECTION:

Wear dust resistant safety goggles where there is danger of eye contact.

### PROTECTIVE CLOTHING:

Wear appropriate clothing to prevent repeated or prolonged skin contact.

### HYGIENIC WORK PRACTICES:

Wash promptly with soap and water if skin becomes contaminated. Change work clothing daily if there is any possibility of contamination.

## 9. PHYSICAL AND CHEMICAL PROPERTIES

<b>APPEARANCE/PHYSICAL STATE:</b>	Powder, dust.
<b>COLOR:</b>	White.
<b>ODOR:</b>	Odorless or no characteristic odor.
<b>SOLUBILITY DESCRIPTION:</b>	Very soluble in water.

<b>SOLUBILITY VALUE (g/100g H<sub>2</sub>O 68°F):</b>	75	
<b>DENSITY/SPECIFIC GRAVITY (g/ml):</b>	2.2	<b>TEMPERATURE (°F):</b> 68
<b>VAPOR DENSITY (air=1):</b>	N/D	
<b>VAPOR PRESSURE:</b>	N/D	<b>TEMPERATURE (°F):</b>
<b>pH-VALUE, DILUTED SOLUTION:</b>	N/D	<b>CONCENTRATION (% ,M):</b>

---

## 10. STABILITY AND REACTIVITY

---

**STABILITY:** Normally stable.

**CONDITIONS TO AVOID:**  
Avoid contact with water.

**HAZARDOUS POLYMERIZATION:**  
Will not polymerize.

**POLYMERIZATION DESCRIPTION:**  
Not relevant.

**MATERIALS TO AVOID:**  
Sulfuric acid

**HAZARDOUS DECOMPOSITION PRODUCTS:**  
No specific hazardous decomposition products noted.

---

## 11. TOXICOLOGICAL INFORMATION

---

**TOXIC DOSE - LD 50:** 1000 mg/kg (oral rat)

---

## 12. ECOLOGICAL INFORMATION

---

**ECOLOGICAL INFORMATION:**  
Contact M-I Environmental Affairs for ecological information.

---

## 13. DISPOSAL CONSIDERATIONS

---

**WASTE MANAGEMENT:**  
This product, should it become a waste, is not hazardous by U.S. RCRA criteria.

**DISPOSAL METHODS:**  
Recover and reclaim or recycle, if practical. Should this product become a waste, dispose of in a permitted industrial landfill. Ensure that containers are empty by RCRA criteria prior to disposal in a permitted industrial landfill.

---

## 14. TRANSPORT INFORMATION

---

**PRODUCT RQ:** N/A

**U.S. DOT:**  
**U.S. DOT CLASS:** Not regulated.

**CANADIAN TRANSPORT:**  
**TDGR CLASS:** Not regulated.

**SEA TRANSPORT:**  
**IMDG CLASS:** Not regulated.

**AIR TRANSPORT:**  
**ICAO CLASS:** Not regulated.

## 15. REGULATORY INFORMATION

### REGULATORY STATUS OF INGREDIENTS:

NAME:	CAS No:	TSCA:	CERCLA:	SARA 302:	SARA 313:	DSL(CAN):
Calcium chloride	10043-52-4	Yes	No	No	No	Yes

### US FEDERAL REGULATIONS:

**WASTE CLASSIFICATION:** Not a hazardous waste by U.S. RCRA criteria. See Section 13.

### REGULATORY STATUS:

This Product or its components, if a mixture, is subject to following regulations (Not meant to be all inclusive - selected regulations represented):

SECTION 313: This product does not contain toxic chemical subject to the reporting requirements of Section 313 of Title III of the Superfund Amendment and Reauthorization Act of 1986 and 40 CFR Part 372.

SARA 311 Categories:

1: Immediate (Acute) Health Effects.

The components of this product are listed on or are exempt from the following international chemical registries:

TSCA (U.S.)

DSL (Canada)

EINECS (Europe)

### STATE REGULATIONS:

#### STATE REGULATORY STATUS:

This product or its components, if a mixture, is subject to following regulations (Not meant to be all inclusive - selected regulations represented):

None.

PROPOSITION 65: This product does not contain chemicals considered by the State of California's Safe Drinking Water and Toxic Enforcement Act of 1986 as causing cancer or reproductive toxicity, and for which warnings are now required.

### CANADIAN REGULATIONS:

#### LABELS FOR SUPPLY:



### REGULATORY STATUS:

This Material Safety Data Sheet has been prepared in compliance with the Controlled Product Regulations.

Canadian WHMIS Classification: D2B - Other Toxic Effects: Toxic Material

## 16. OTHER INFORMATION

### NPCA HMIS HAZARD INDEX:

1 Slight Hazard

### FLAMMABILITY:

0 Minimal Hazard

**REACTIVITY:** 1 Slight Hazard  
**NPCA HMIS PERS. PROTECT. INDEX:** E - Safety Glasses, Gloves, Dust Respirator

**USER NOTES:** N/A = Not applicable N/D = Not determined

**INFORMATION SOURCES:** OSHA Permissible Exposure Limits, 29 CFR 1910, Subpart Z, Section 1910.1000, Air Contaminants.

ACGIH Threshold Limit Values and Biological Exposure Indices for Chemical Substances and Physical Agents (latest edition).

Sax's Dangerous Properties of Industrial Materials, 9th ed., Lewis, R.J. Sr., (ed.), VNR, New York, New York, (1997).  
Product information provided by the commercial vendor(s).

**PREPARED BY:** Sam Hoskin

**REVISION No./Repl. MSDS of:** 1 / September 7, 1995

**MSDS STATUS:** Approved.

**DATE:** August 19, 1998

---

**DISCLAIMER:**

MSDS furnished independent of product sale. While every effort has been made to accurately describe this product, some of the data are obtained from sources beyond our direct supervision. We cannot make any assertions as to its reliability or completeness; therefore, user may rely on it only at user's risk. We have made no effort to censor or conceal deleterious aspects of this product. Since we cannot anticipate or control the conditions under which this information and product may be used, we make no guarantee that the precautions we have suggested will be adequate for all individuals and/or situations. It is the obligation of each user of this product to comply with the requirements of all applicable laws regarding use and disposal of this product. Additional information will be furnished upon request to assist the user; however, no warranty, either expressed or implied, nor liability of any nature with respect to this product or to the data herein is made or incurred hereunder.



WHMIS (Pictograms)	WHMIS (Classification)	Protective Clothing	TDG (pictograms)
	<b>Not controlled</b>		

<b>Section 1. Chemical Product and Company Identification</b>			
<b>Product Name</b>	<b>CHAIN OIL (SUMMER, WINTER)</b>	<b>Code</b>	CHAS, 490-431 CHAW, 490-430
<b>Synonym</b>	Not available	<b>Validated on</b>	5/6/2003.
<b>Manufacturer</b>	PETRO-CANADA P.O. Box 2844 Calgary, Alberta T2P 3E3	<b>In case of Emergency</b>	Petro-Canada: 403-296-3000 Canutec Transportation: 613-996-6666 Poison Control Centre: Consult local telephone directory for emergency number(s).
<b>Material Uses</b>	These products are designed for lubrication of chain saw chains in both high and low ambient temperatures.		

<b>Section 2. Composition and Information on Ingredients</b>					
			<i>Exposure Limits (ACGIH)</i>		
<b>Name</b>	<b>CAS #</b>	<b>% (V/V)</b>	<b>TLV-TWA(8 h)</b>	<b>STEL</b>	<b>CEILING</b>
1) Mixture of severely hydrotreated and hydrocracked and/or solvent-refined base oil (petroleum) and other proprietary, non-hazardous additives.	Mixture	100	5 mg/m <sup>3</sup> (oil mist)	10 mg/m <sup>3</sup> (oil mist)	Not established
<b>Manufacturer Recommendation</b>	Not applicable				
<b>Other Exposure Limits</b>	Consult local, state, provincial or territory authorities for acceptable exposure limits.				

<b>Section 3. Hazards Identification.</b>	
<b>Potential Health Effects</b>	Non irritating to slight transient irritation to skin and eyes, but no permanent damage. Relatively non-toxic via ingestion. This product has a low vapour pressure and is not expected to present an inhalation exposure at ambient conditions. Upon heating to high temperatures, or mechanical actions which may produce vapours or mists, inhalation of product may cause irritation of the breathing passages. For more information, refer to Section 11.

<b>Section 4. First Aid Measures</b>	
<b>Eye Contact</b>	IMMEDIATELY flush eyes with running water for at least 15 minutes, keeping eyelids open. Seek medical attention.
<b>Skin Contact</b>	Remove contaminated clothing - launder before reuse. Wash gently and thoroughly the contaminated skin with running water and non-abrasive soap. Seek medical attention.
<b>Inhalation</b>	Evacuate the victim to a safe area as soon as possible. If the victim is not breathing, perform artificial respiration. Allow the victim to rest in a well ventilated area. Seek medical attention.
<b>Ingestion</b>	DO NOT induce vomiting because of danger of aspirating liquid into lungs. Seek medical attention.
<b>Note to Physician</b>	Not available

<b>Section 5. Fire-fighting Measures</b>			
<b>Flammability</b>	May be combustible at high temperature.	<b>Flammable Limits</b>	Not available
<b>Flash Points</b>	OPEN CUP: ≥168°C (334.4°F) (Cleveland)	<b>Auto-Ignition Temperature</b>	Not available
<b>Fire Hazards in Presence of Various Substances</b>	Low fire hazard. This material must be heated before ignition will occur.	<b>Explosion Hazards in Presence of Various Substances</b>	Do not cut, weld, heat, drill or pressurize empty container. Containers may explode in heat of fire.
<b>Products of Combustion</b>	Carbon oxides (CO, CO <sub>2</sub> ), nitrogen oxides (NO <sub>x</sub> ), sulphur oxides (SO <sub>x</sub> ), sulphur compounds (H <sub>2</sub> S), phosphorus compounds (PO <sub>x</sub> ), smoke and irritating vapours as products of incomplete combustion.		

<b>Fire Fighting Media and Instructions</b>	NAERG96, GUIDE 171, Substances (low to moderate hazard). If tank, rail car or tank truck is involved in a fire, ISOLATE for 800 meters (0.5 mile) in all directions; also, consider initial evacuation for 800 meters (0.5 mile) in all directions. Shut off fuel to fire if it is possible to do so without hazard. If this is impossible, withdraw from area and let fire burn out under controlled conditions. Withdraw immediately in case of rising sound from venting safety device or any discolouration of tank due to fire. Cool containing vessels with water spray in order to prevent pressure build-up, autoignition or explosion. SMALL FIRE: use DRY chemicals, foam, water spray or CO2. LARGE FIRE: use water spray, fog or foam. For small outdoor fires, portable fire extinguishers may be used, and self contained breathing apparatus (SCBA) may not be required. For all indoor fires and any significant outdoor fires, SCBA is required. Respiratory and eye protection are required for fire fighting personnel.
---	--

### Section 6. Accidental Release Measures

<b>Material Release or Spill</b>	Consult current National Emergency Response Guide Book (NAERG) for appropriate spill measures if necessary. Extinguish all ignition sources. Stop leak if safe to do so. Dike spilled material. Use appropriate inert absorbent material to absorb spilled product. Collect used absorbent for later disposal. Avoid contact with spilled material. Avoid contaminating sewers, streams, rivers and other water courses with spilled material. Notify appropriate authorities immediately.
----------------------------------	--

### Section 7. Handling and Storage

<b>Handling</b>	Avoid contact with any sources of ignition, flames, heat, and sparks. Avoid skin contact. Avoid eye contact. Avoid inhalation of product vapours or mists. Empty containers may contain product residue. Do not pressurize, cut, heat, or weld empty containers. Do not reuse containers without commercial cleaning and/or reconditioning. Personnel who handle this material should practice good personal hygiene during and after handling to help prevent accidental ingestion of this product. Properly dispose of contaminated leather articles including shoes that cannot be decontaminated.
<b>Storage</b>	Store in dry, cool, well-ventilated area. Keep container tightly closed. Store away from incompatible and reactive materials (See section 5 and 10).

### Section 8. Exposure Controls/Personal Protection

<b>Engineering Controls</b>	For normal application, special ventilation is not necessary. If user's operations generate vapours or mist, use ventilation to keep exposure to airborne contaminants below the exposure limit. Make-up air should always be supplied to balance air removed by exhaust ventilation. Ensure that eyewash station and safety shower are close to work-station.
<b>Personal Protection - <i>The selection of personal protective equipment varies, depending upon conditions of use.</i></b>	
<b>Eyes</b>	Eye protection (i.e., safety glasses, safety goggles and/or face shield) should be determined based on conditions of use. If product is used in an application where splashing may occur, the use of safety goggles and/or a face shield should be considered.
<b>Body</b>	Wear appropriate clothing to prevent skin contact. As a minimum long sleeves and trousers should be worn.
<b>Respiratory</b>	Where concentrations in air may exceed the occupational exposure limits given in Section 2 (and those applicable to your area) and where engineering, work practices or other means of exposure reduction are not adequate, NIOSH approved respirators may be necessary to prevent overexposure by inhalation.
<b>Hands</b>	Wear appropriate chemically protective gloves. When handling hot product ensure gloves are heat resistant and insulated.
<b>Feet</b>	Wear appropriate footwear to prevent product from coming in contact with feet and skin.

### Section 9. Physical and Chemical Properties

<b>Physical State and Appearance</b>	Stringy liquid.	<b>Viscosity</b>	CHAS: 155 cSt @ 40°C (104°F), 16.2 cSt @ 100°C (212°F), VI=109 CHAW: 32 @ 40°C (104°F), 6.29 cSt @ 100°C (212°F), VI=151
<b>Colour</b>	Dark red.	<b>Pour Point</b>	CHAS: -21°C (-6°F) CHAW: -42°C (-44°F)
<b>Odour</b>	Slight petroleum oil like.	<b>Softening Point</b>	Not applicable.
<b>Odour Threshold</b>	Not available	<b>Dropping Point</b>	Not applicable.
<b>Boiling Point</b>	Not available	<b>Penetration</b>	Not applicable.
<b>Density</b>	0.831 - 0.88 kg/L @ 15°C (59°F).	<b>Oil / Water Dist. Coefficient</b>	Not available
<b>Vapour Density</b>	Not available	<b>Ionicity (in water)</b>	Not available
<b>Vapour Pressure</b>	Negligible at ambient temperature and pressure.	<b>Dispersion Properties</b>	Not available
<b>Volatility</b>	Non-volatile.	<b>Solubility</b>	Insoluble in water.

**Section 10. Stability and Reactivity**

<b>Corrosivity</b>	Copper corrosion, 3h, 100°C (ASTM D0130): 1a		
<b>Stability</b>	The product is stable under normal handling and storage conditions.	<b>Hazardous Polymerization</b>	Will not occur under normal working conditions.
<b>Incompatible Substances / Conditions to Avoid</b>	Reactive with oxidizing agents, reducing agents and acids.	<b>Decomposition Products</b>	May release CO <sub>x</sub> , NO <sub>x</sub> , SO <sub>x</sub> , H <sub>2</sub> S, PO <sub>x</sub> , smoke and irritating vapours when heated to decomposition.

**Section 11. Toxicological Information**

<b>Routes of Entry</b>	Skin contact, eye contact, inhalation and ingestion.		
<b>Acute Lethality</b>	Not available		
<b>Chronic or Other Toxic Effects</b>			
Dermal Route:	Prolonged or repeated contact may cause skin irritation characterized by dermatitis or oil acne.		
Inhalation Route:	Negligible breathing hazard at normal temperatures (up to 38°C) or recommended blending temperatures. Elevated temperatures or mechanical action may form vapours, mists or fumes. Inhalation of oil mists or vapours from hot oil may cause irritation of the upper respiratory tract.		
Oral Route:	Low toxicity; has laxative effect.		
Eye Irritation/Inflammation:	Repeated or prolonged contact may cause transient irritation, but no permanent damage.		
Immunotoxicity:	Not available		
Skin Sensitization:	This product is not expected to be a skin sensitizer, based on the available data and the known hazards of the components.		
Respiratory Tract Sensitization:	This product is not expected to be a respiratory tract sensitizer, based on the available data and the known hazards of the components.		
Mutagenic:	This product is not expected to be a mutagen, based on the available data and the known hazards of the components.		
Reproductive Toxicity:	This product is not expected to be a reproductive hazard, based on the available data and the known hazards of the components.		
Teratogenicity/Embryotoxicity:	This product is not expected to be a teratogen or an embryotoxin, based on the available data and the known hazards of the components.		
Carcinogenicity (ACGIH):	This product is not known to contain any chemicals at reportable quantities that are listed as A1 or A2 carcinogens by ACGIH.		
Carcinogenicity (IARC):	This product is not known to contain any chemicals at reportable quantities that are listed as group 1, 2A or 2B carcinogens by IARC.		
Carcinogenicity (NTP):	This product is not known to contain any chemicals at reportable quantities that are listed as carcinogens by NTP.		
Carcinogenicity (IRIS):	Not available		
Carcinogenicity (OSHA):	This product is not known to contain any chemicals at reportable quantities that are listed as carcinogens by OSHA.		
<b>Other Considerations</b>	No additional remark		

**Section 12. Ecological Information**

<b>Environmental Fate</b>	Not available	<b>Persistence/Bioaccumulation Potential</b>	Not available
<b>BOD5 and COD</b>	Not available	<b>Products of Biodegradation</b>	Not available
<b>Additional Remarks</b>	No additional remark.		



**Section 13. Disposal Considerations**

<b>Waste Disposal</b>	Spent/ used/ waste product may meet the requirements of a hazardous waste. Consult your local or regional authorities. Ensure that waste management processes are in compliance with government requirements and local disposal regulations.		
-----------------------	--	--	--

**Section 14. Transport Information**

<b>TDG Classification</b>	Not controlled under TDG (Canada).	<b>Special Provisions for Transport</b>	Not applicable.
---------------------------	------------------------------------	---	-----------------

**Section 15. Regulatory Information**

<b>Other Regulations</b>		This product is acceptable for use under the provisions of WHMIS-CPR. All components of this formulation are listed on the CEPA-DSL (Domestic Substances List).																									
		All components of this formulation are listed on the US EPA-TSCA Inventory.																									
		All components of this formulation are listed on EINECS or are exempt.																									
		This product has been classified in accordance with the hazard criteria of the Controlled Products Regulations (CPR) and the MSDS contains all of the information required by the CPR.																									
		Please contact Product Safety for more information.																									
<b>DSD/DPD (Europe)</b>	Not classified under the Dangerous Substances or Dangerous Preparations Directives.	<b>HCS (U.S.A.)</b>	Not controlled under the HCS (United States).																								
<b>ADR (Europe) (Pictograms)</b>		<b>DOT (U.S.A) (Pictograms)</b>																									
<b>HMS (U.S.A.)</b>	<table border="1"> <tr> <td>Health Hazard</td> <td>1</td> </tr> <tr> <td>Fire Hazard</td> <td>1</td> </tr> <tr> <td>Reactivity</td> <td>0</td> </tr> <tr> <td>Personal Protection</td> <td>B</td> </tr> </table>	Health Hazard	1	Fire Hazard	1	Reactivity	0	Personal Protection	B	<b>NFPA (U.S.A.)</b>	<table border="1"> <tr> <td>Health</td> <td>1</td> <td>Fire Hazard</td> <td>1</td> <td>Reactivity</td> <td>0</td> <td>Specific hazard</td> <td></td> </tr> <tr> <td></td> <td></td> <td></td> <td></td> <td></td> <td></td> <td></td> <td></td> </tr> </table>	Health	1	Fire Hazard	1	Reactivity	0	Specific hazard									
Health Hazard	1																										
Fire Hazard	1																										
Reactivity	0																										
Personal Protection	B																										
Health	1	Fire Hazard	1	Reactivity	0	Specific hazard																					
		<b>Rating</b>	0 Insignificant 1 Slight 2 Moderate 3 High 4 Extreme																								



**Section 16. Other Information**

<b>References</b>	Available upon request. * Marque de commerce de Petro-Canada - Trademark
<b>Glossary</b>	<p>ACGIH - American Conference of Governmental Industrial Hygienists ADR - Agreement on Dangerous goods by Road (Europe) ASTM - American Society for Testing and Materials ( BOD5 - Biological Oxygen Demand in 5 days CAN/CGA B149.2 Propane Installation Code CAS - Chemical Abstract Services CEPA - Canadian Environmental Protection Act CERCLA - Comprehensive Environmental Response, Compensation and Liability Act CFR - Code of Federal Regulations CHIP - Chemicals Hazard Information and Packaging Approved Supply List COD5 - Chemical Oxygen Demand in 5 days CPR - Controlled Products Regulations DOT - Department of Transport DSCL - Dangerous Substances Classification and Labeling (Europe) DSD/DPD - Dangerous Substances or Dangerous Preparations Directives (Europe) DSL - Domestic Substance List EEC/EU - European Economic Community/European Union EINECS - European Inventory of Existing Commercial Chemical Substances EPCRA - Emergency Planning and Community Right to Know Act FDA - Food and Drug Administration FIFRA - Federal Insecticide, Fungicide and Rodenticide Act HCS - Hazardous Communication System HMS - Hazardous Material Information System IARC - International Agency for Research on Cancer</p> <p>IRIS - Integrated Risk Information System LD50/LC50 - Lethal Dose/Concentration kill 50% LDLo/LCLo - Lowest Published Lethal Dose/Concentration NAERG'96 - North American Emergency Response Guide Book (1996) NFPA - National Fire Prevention Association NIOSH - National Institute for Occupational Safety &amp; Health NPRI - National Pollutant Release Inventory NSNR - New Substances Notification Regulations (Canada) NTP - National Toxicology Program OSHA - Occupational Safety &amp; Health Administration PEL - Permissible Exposure Limit RCRA - Resource Conservation and Recovery Act SARA - Superfund Amendments and Reorganization Act SD - Single Dose STEL - Short Term Exposure Limit (15 minutes) TDG - Transportation Dangerous Goods (Canada) TDL0/TCL0 - Lowest Published Toxic Dose/Concentration TLm - Median Tolerance Limit TLV-TWA - Threshold Limit Value-Time Weighted Average TSCA - Toxic Substances Control Act USEPA - United States Environmental Protection Agency USP - United States Pharmacopoeia WHMIS - Workplace Hazardous Material Information System</p>

<b>For Copy of MSDS</b> <b>Internet: <a href="http://www.petro-canada.ca">www.petro-canada.ca</a></b>	<b>Prepared by Product Safety - JDW on 5/6/2003.</b>
<b>Lubricants:</b> <b>Western Canada, telephone: 1-800-661-1199; fax: (780) 464-9564</b> <b>Ontario &amp; Central Canada, telephone: 1-800-268-5850 and (905) 822-4222; fax: 1-800-201-6285</b> <b>Quebec &amp; Eastern Canada, telephone: 1-800-576-1686; fax: 800-201-6285</b>	<b>Data entry by Product Safety - JDW.</b>
<b>For Product Safety Information: (905) 804-4752</b>	

***To the best of our knowledge, the information contained herein is accurate. However, neither the above named supplier nor any of its subsidiaries assumes any liability whatsoever for the accuracy or completeness of the information contained herein. Final determination of suitability of any material is the sole responsibility of the user. All materials may present unknown hazards and should be used with caution. Although certain hazards are described herein, we cannot guarantee that these are the only hazards that exist.***



<b>WHMIS (Pictograms)</b>	<b>WHMIS (Classification)</b>	<b>Protective Clothing</b>	<b>TDG (pictograms)</b>
	<b>B-3, D-2B</b>		

<b>Section 1. Chemical Product and Company Identification</b>	
<b>Product Name</b> <b>DIESEL FUEL</b>	<b>Code</b> W104, W293 SAP: 120, 121, 122, 287
<b>Synonym</b> Diesel 50, Diesel 50 LS, #1 Diesel, #1 Diesel LS, Diesel LC, Seasonal Diesel, Seasonal Diesel LS, Diesel AA, Domestic Marine Diesel, International marine Diesel, Seasonal Diesel Locomotive, Domestic Marine diesel LS, diesel -20°C (LS), LSD, Low Sulphur Diesel, dyed diesel, marked diesel, coloured diesel, Naval Distillate, Ultra Low Sulphur Diesel, ULS Diesel, Mining Diesel, Mining Diesel Special, Mining Diesel Special LS, High Flash Mining Diesel, Furnace Oil, Stove Oil.	<b>Validated on</b> 2/6/2004.
<b>Manufacturer</b> PETRO-CANADA P.O. Box 2844 Calgary, Alberta T2P 3E3	<b>In case of Emergency</b> Petro-Canada: 403-296-3000 Canutec Transportation: 613-996-6666 Poison Control Centre: Consult local telephone directory for emergency number(s).
<b>Material Uses</b> Diesel fuels are distillate fuels suitable for use in high and medium speed internal combustion engines of the compression ignition type. Mining Diesel has a higher flash point requirement, for safe use in underground mines.	

<b>Section 2. Composition and Information on Ingredients</b>					
			<i>Exposure Limits (ACGIH)</i>		
Name	CAS #	% (V/V)	TLV-TWA(8 h)	STEL	CEILING
1) Diesel oil.	68334-30-5	>99.9	100 mg/m <sup>3</sup> (as total hydrocarbons) *	Not established	Not established
2) Proprietary additives.	Not available	<0.1	Not established	Not established	Not established
Aromatic content is 50% maximum (benzene: nil). Sulphur content is 0-0.50%.					
<b>Manufacturer Recommendation</b>	* Avoid prolonged or repeated skin contact to diesel fuels which can lead to dermal irritation and may be associated with an increased risk of skin cancer.				
<b>Other Exposure Limits</b>	Consult local, state, provincial or territory authorities for acceptable exposure limits.				

<b>Section 3. Hazards Identification.</b>	
<b>Potential Health Effects</b>	Combustible liquid. Exercise caution when handling this material. Contact with this product may cause skin and eye irritation. Prolonged or repeated contact may cause skin irritation, defatting, drying and dermatitis. Inhalation of this product may cause respiratory tract irritation and Central Nervous System (CNS) Depression, symptoms of which may include; weakness, dizziness, slurred speech, drowsiness, unconsciousness and in cases of severe overexposure; coma and death. Ingestion of this product may cause gastro-intestinal irritation. Aspiration of this product may result in severe irritation or burns to the respiratory tract. For more information refer to Section 11 of this MSDS.

<b>Section 4. First Aid Measures</b>	
<b>Eye Contact</b>	IMMEDIATELY flush eyes with running water for at least 15 minutes, keeping eyelids open. Seek medical attention.
<b>Skin Contact</b>	Remove contaminated clothing - launder before reuse. Wash gently and thoroughly the contaminated skin with running water and non-abrasive soap. Seek medical attention.
<b>Inhalation</b>	Evacuate the victim to a safe area as soon as possible. If the victim is not breathing, perform artificial respiration. Allow the victim to rest in a well ventilated area. Seek medical attention.
<b>Ingestion</b>	DO NOT induce vomiting because of danger of aspirating liquid into lungs. Seek medical attention.
<b>Note to Physician</b>	Not available

**Section 5. Fire-fighting Measures**

<b>Flammability</b>	Class II - combustible liquid (NFPA).	<b>Flammable Limits</b>	LOWER: 0.7%, UPPER: 6% (NFPA)
<b>Flash Points</b>	Diesel Fuel: Closed Cup: >40°C (>104°F) Marine Diesel Fuel: Closed Cup: >60°C (>140°F) Mining Diesel: Closed Cup: 52°C (126°F)	<b>Auto-Ignition Temperature</b>	225°C (437°F)
<b>Fire Hazards in Presence of Various Substances</b>	Flammable in presence of open flames, sparks, or heat. Vapours are heavier than air and may travel considerable distance to sources of ignition and flash back. This product can accumulate static charge and ignite. May accumulate in confined spaces.	<b>Explosion Hazards in Presence of Various Substances</b>	Containers may explode in heat of fire. Do not cut, weld, heat, drill or pressurize empty container. Vapour explosion hazard indoors, outdoors or in sewers. Runoff to sewer may create fire or explosion hazard.
<b>Products of Combustion</b>	Carbon oxides (CO, CO <sub>2</sub> ), nitrogen oxides (NO <sub>x</sub> ), sulphur oxides (SO <sub>x</sub> ), sulphur compounds (H <sub>2</sub> S), water vapour (H <sub>2</sub> O), smoke and irritating vapours as products of incomplete combustion. See Section 11 (Other Considerations) for information regarding the toxicity of the combustion products.		
<b>Fire Fighting Media and Instructions</b>	<p>NAERG96, GUIDE 128, Flammable liquids (Non-polar/Water-immiscible). CAUTION: This product has a moderate flash point above 40°C: Use of water spray when fighting fire may be inefficient.</p> <p>If tank, rail car or tank truck is involved in a fire, ISOLATE for 800 meters (1/2 mile) in all directions; also consider initial evacuation for 800 meters (1/2 mile) in all directions.</p> <p>SMALL FIRES: Dry chemical, CO<sub>2</sub>, water spray or regular foam. LARGE FIRES: Water spray, fog or regular foam. Do not use straight streams. Move containers from fire area if you can do it without risk. Fires Involving Tanks or Car/Trailer Loads: Fight fire from maximum distance or use unmanned hose holders or monitor nozzles.</p> <p>Cool containers with flooding quantities of water until well after fire is out. Withdraw immediately in case of rising sound from venting devices or any discolouration of tank. ALWAYS stay away from the ends of tanks. For massive fire, use unmanned hose holders or monitor nozzles; if this is impossible withdraw from area and let fire burn. Wear positive pressure self-contained breathing apparatus (SCBA). Structural firefighters' protective clothing will only provide limited protection.</p>		

**Section 6. Accidental Release Measures**

<b>Material Release or Spill</b>	Consult current National Emergency Response Guide Book (NAERG) for appropriate spill measures if necessary. IN THE EVENT OF A LARGE SPILL CONSIDER THE FOLLOWING CONTROL MEASURES: Extinguish all ignition sources. Stop leak if safe to do so. Ventilate area. Dike spilled material. Use appropriate inert absorbent material to absorb spilled product. Collect used absorbent for later disposal. Avoid contact with spilled material. Avoid breathing vapours or mists of material. Avoid contaminating sewers, streams, rivers and other water courses with spilled material. Evacuate non-essential personnel. Ensure clean-up personnel wear appropriate personal protective equipment. Ground and bond all equipment used to clean up the spilled material, as it may be a static accumulator. Notify appropriate authorities immediately.
----------------------------------	---

**Section 7. Handling and Storage**

<b>Handling</b>	COMBUSTIBLE MATERIAL. Handle with care. Avoid contact with any sources of ignition, flames, heat, and sparks. Avoid skin contact. Avoid eye contact. Avoid inhalation of product vapours or mists. Empty containers may contain product residue. Do not pressurize, cut, heat, or weld empty containers. Do not reuse containers without commercial cleaning and/or reconditioning. Personnel who handle this material should practice good personal hygiene during and after handling to help prevent accidental ingestion of this product. Properly dispose of contaminated leather articles including shoes that cannot be decontaminated. Avoid confined spaces and areas with poor ventilation. Ensure all equipment is grounded/bonded. Wear proper personal protective equipment (See Section 8).
<b>Storage</b>	Store away from heat and sources of ignition. Store in dry, cool, well-ventilated area. Store away from incompatible and reactive materials (See section 5 and 10). Ensure the storage containers are grounded/bonded.

**Section 8. Exposure Controls/Personal Protection**

<b>Engineering Controls</b>	For normal application, special ventilation is not necessary. If user's operations generate vapours or mist, use ventilation to keep exposure to airborne contaminants below the exposure limit. Make-up air should always be supplied to balance air removed by exhaust ventilation. Ensure that eyewash station and safety shower are close to work-station.
<b>Personal Protection - <i>The selection of personal protective equipment varies, depending upon conditions of use.</i></b>	
<b>Eyes</b>	Eye protection (i.e., safety glasses, safety goggles and/or face shield) should be determined based on conditions of use. If product is used in an application where splashing may occur, the use of safety goggles and/or a face shield should be considered.
<b>Body</b>	Wear appropriate clothing to prevent skin contact. As a minimum long sleeves and trousers should be worn.
<b>Respiratory</b>	Where concentrations in air may exceed the occupational exposure limits given in Section 2 (and those applicable to your area) and where engineering, work practices or other means of exposure reduction are not adequate, NIOSH approved respirators may be necessary to prevent overexposure by inhalation.
<b>Hands</b>	Wear appropriate chemically protective gloves. When handling hot product ensure gloves are heat resistant and insulated.
<b>Feet</b>	Wear appropriate footwear to prevent product from coming in contact with feet and skin.

**Section 9. Physical and Chemical Properties**

<b>Physical State and Appearance</b>	Bright oily liquid.	<b>Viscosity</b>	1.3 - 4.1 cSt @ 40°C (104°F)
<b>Colour</b>	Clear to yellow / brown (may be dyed for taxation purposes).	<b>Pour Point</b>	Variable, -50°C to 0°C (-58°F to -32°F)
<b>Odour</b>	Petroleum oil like.	<b>Softening Point</b>	Not applicable.
<b>Odour Threshold</b>	Not available	<b>Dropping Point</b>	Not applicable.
<b>Boiling Point</b>	150 - 371°C (302-700°F)	<b>Penetration</b>	Not applicable.
<b>Density</b>	0.80 - 0.85 kg/L @ 15°C (59°F)	<b>Oil / Water Dist. Coefficient</b>	Not available
<b>Vapour Density</b>	4.5 (Air = 1)	<b>Ionicity (in water)</b>	Not applicable.
<b>Vapour Pressure</b>	Not available	<b>Dispersion Properties</b>	Not available
<b>Volatility</b>	Semivolatile to volatile.	<b>Solubility</b>	Insoluble in cold water, soluble in non-polar hydrocarbon solvents.

**Section 10. Stability and Reactivity**

<b>Corrosivity</b>	Not available		
<b>Stability</b>	The product is stable under normal handling and storage conditions.	<b>Hazardous Polymerization</b>	Will not occur under normal working conditions.
<b>Incompatible Substances / Conditions to Avoid</b>	Reactive with oxidizing agents and acids.	<b>Decomposition Products</b>	May release COx, NOx, SOx, H2S, H2O, smoke and irritating vapours when heated to decomposition.

**Section 11. Toxicological Information**

<b>Routes of Entry</b>	Skin contact, eye contact, inhalation, and ingestion.
<b>Acute Lethality</b>	Acute oral toxicity (LD50): 7500 mg/kg (rat).
<b>Chronic or Other Toxic Effects</b>	
Dermal Route:	This product contains a component (at $\geq 1\%$ ) that can cause skin irritation. Therefore, this product is considered to be a skin irritant. Prolonged or repeated contact may defat and dry skin, and cause dermatitis. (See Other Considerations)
Inhalation Route:	Inhalation of this product may cause respiratory tract irritation. Inhalation of this product may cause Central Nervous System (CNS) Depression, symptoms of which may include; weakness, dizziness, slurred speech, drowsiness, unconsciousness and in cases of severe overexposure; coma and death.
Oral Route:	Ingestion of this product may cause gastro-intestinal irritation. Aspiration of this product may result in severe irritation or burns to the respiratory tract. Ingestion of this product may cause Central Nervous System (CNS) Depression, symptoms of which may include; weakness, dizziness, slurred speech, drowsiness, unconsciousness and in cases of severe overexposure; coma and death.
Eye Irritation/Inflammation:	This product contains a component (at $\geq 1\%$ ) that can cause eye irritation. Therefore, this product is considered to be an eye irritant.
Immunotoxicity:	Not available
Skin Sensitization:	Contact with this product is not expected to cause skin sensitization, based upon the available data and the known hazards of the components.
Respiratory Tract Sensitization:	Contact with this product is not expected to cause respiratory tract sensitization, based upon the available data and the known hazards of the components.
Mutagenic:	This product is not known to contain any components at $\geq 0.1\%$ that have been shown to cause mutagenicity. Therefore, based upon the available data and the known hazards of the components, this product is not expected to be a mutagen.
Reproductive Toxicity:	This product is not known to contain any components at $\geq 0.1\%$ that have been shown to cause reproductive toxicity. Therefore, based upon the available data and the known hazards of the components, this product is not expected to be a reproductive toxin.
Teratogenicity/Embryotoxicity:	This product is not known to contain any components at $\geq 0.1\%$ that have been shown to cause teratogenicity and/or embryotoxicity. Therefore, based upon the available data and the known hazards of the components, this product is not expected to be a teratogen/embryotoxin.
Carcinogenicity (ACGIH):	ACGIH A3: animal carcinogen. [Diesel oil] (See Other Considerations)
Carcinogenicity (IARC):	This product is not known to contain any chemicals at reportable quantities that are listed as Group 1, 2A, or 2B carcinogens by IARC.
Carcinogenicity (NTP):	This product is not known to contain any chemicals at reportable quantities that are listed as carcinogens by NTP.
Carcinogenicity (IRIS):	This product is not known to contain any chemicals at reportable quantities that are listed as carcinogens by IRIS.

Carcinogenicity (OSHA): This product is not known to contain any chemicals at reportable quantities that are listed as carcinogens by OSHA.

**Other Considerations** Avoid prolonged or repeated skin contact to diesel fuels which can lead to dermal irritation and may be associated with an increased risk of skin cancer.

Diesel engine exhaust particulate is probably carcinogenic to humans (IARC Group 2A).

### Section 12. Ecological Information

<b>Environmental Fate</b>	Not available	<b>Persistence/ Bioaccumulation Potential</b>	Not available
<b>BOD5 and COD</b>	Not available	<b>Products of Biodegradation</b>	Not available
<b>Additional Remarks</b>	No additional remark.		

### Section 13. Disposal Considerations

**Waste Disposal** Spent/ used/ waste product may meet the requirements of a hazardous waste. Consult your local or regional authorities. Ensure that waste management processes are in compliance with government requirements and local disposal regulations.

### Section 14. Transport Information

<b>TDG Classification</b>	DIESEL FUEL, 3, UN1202, PGIII (CL-TDG)	<b>Special Provisions for Transport</b>	See Transportation of Dangerous Goods Regulations.
---------------------------	--	---	--

### Section 15. Regulatory Information

**Other Regulations** This product is acceptable for use under the provisions of WHMIS-CPR. All components of this formulation are listed on the CEPA-DSL (Domestic Substances List).

All components of this formulation are listed on the US EPA-TSCA Inventory.

All components of this product are on the European Inventory of Existing Commercial Chemical Substances (EINECS).

This product has been classified in accordance with the hazard criteria of the Controlled Products Regulations (CPR) and the MSDS contains all of the information required by the CPR.

Please contact Product Safety for more information.

<b>DSD/DPD (Europe)</b>	Not evaluated.	<b>HCS (U.S.A.)</b>	CLASS: Irritating substance. CLASS: Target organ effects. CLASS: Combustible liquid having a flash point between 37.8°C (100°F) and 93.3°C (200°F).
-------------------------	----------------	---------------------	---

<b>ADR (Europe) (Pictograms)</b>	NOT EVALUATED FOR EUROPEAN TRANSPORT NON ÉVALUÉ POUR LE TRANSPORT EUROPÉEN.	<b>DOT (U.S.A) (Pictograms)</b>	
--------------------------------------	--	-------------------------------------	---

<b>HMIS (U.S.A.)</b>	<table border="1"> <tr> <td>Health Hazard</td> <td>2*</td> </tr> <tr> <td>Fire Hazard</td> <td>2</td> </tr> <tr> <td>Reactivity</td> <td>0</td> </tr> <tr> <td>Personal Protection</td> <td>H</td> </tr> </table>	Health Hazard	2*	Fire Hazard	2	Reactivity	0	Personal Protection	H	<b>NFPA (U.S.A.)</b>		<b>Rating</b>	0 Insignificant 1 Slight 2 Moderate 3 High 4 Extreme
Health Hazard	2*												
Fire Hazard	2												
Reactivity	0												
Personal Protection	H												

### Section 16. Other Information

**References** Available upon request.  
\* Marque de commerce de Petro-Canada - Trademark

#### Glossary

ACGIH - American Conference of Governmental Industrial Hygienists  
ADR - Agreement on Dangerous goods by Road (Europe)  
ASTM - American Society for Testing and Materials ( )  
BOD5 - Biological Oxygen Demand in 5 days  
CAN/CGA B149.2 Propane Installation Code  
CAS - Chemical Abstract Services  
CEPA - Canadian Environmental Protection Act  
CERCLA - Comprehensive Environmental Response, Compensation and Liability Act  
CFR - Code of Federal Regulations  
CHIP - Chemicals Hazard Information and Packaging Approved Supply List  
COD5 - Chemical Oxygen Demand in 5 days  
CPR - Controlled Products Regulations  
DOT - Department of Transport  
DSCL - Dangerous Substances Classification and Labeling (Europe)

IRIS - Integrated Risk Information System  
LD50/LC50 - Lethal Dose/Concentration kill 50%  
LDLo/LCLo - Lowest Published Lethal Dose/Concentration  
NAERG'96 - North American Emergency Response Guide Book (1996)  
NFPA - National Fire Prevention Association  
NIOSH - National Institute for Occupational Safety & Health  
NPRI - National Pollutant Release Inventory  
NSNR - New Substances Notification Regulations (Canada)  
NTP - National Toxicology Program  
OSHA - Occupational Safety & Health Administration  
PEL - Permissible Exposure Limit  
RCRA - Resource Conservation and Recovery Act  
SARA - Superfund Amendments and Reorganization Act  
SD - Single Dose  
STEL - Short Term Exposure Limit (15 minutes)

DSD/DPD - Dangerous Substances or Dangerous Preparations Directives (Europe)	TDG - Transportation Dangerous Goods (Canada)
DSL - Domestic Substance List	TDL <sub>o</sub> /TCL <sub>o</sub> - Lowest Published Toxic Dose/Concentration
EEC/EU - European Economic Community/European Union	TL <sub>m</sub> - Median Tolerance Limit
EINECS - European Inventory of Existing Commercial Chemical Substances	TLV-TWA - Threshold Limit Value-Time Weighted Average
EPCRA - Emergency Planning and Community Right to Know Act	TSCA - Toxic Substances Control Act
FDA - Food and Drug Administration	USEPA - United States Environmental Protection Agency
FIFRA - Federal Insecticide, Fungicide and Rodenticide Act	USP - United States Pharmacopoeia
HCS - Hazardous Communication System	WHMIS - Workplace Hazardous Material Information System
HMIS - Hazardous Material Information System	
IARC - International Agency for Research on Cancer	

**For Copy of MSDS**Internet: [www.petro-canada.ca/msds](http://www.petro-canada.ca/msds)

Western Canada, Ontario &amp; Central Canada, telephone: 1-800-668-0220; fax: 1-800-837-1228

Quebec &amp; Eastern Canada, telephone: 514-640-8308; fax: 514-640-8385

For Product Safety Information: (905) 804-4752

Prepared by Product Safety - JDW on 2/6/2004.

Data entry by Product Safety - JDW.

*To the best of our knowledge, the information contained herein is accurate. However, neither the above named supplier nor any of its subsidiaries assumes any liability whatsoever for the accuracy or completeness of the information contained herein. Final determination of suitability of any material is the sole responsibility of the user. All materials may present unknown hazards and should be used with caution. Although certain hazards are described herein, we cannot guarantee that these are the only hazards that exist.*



# Material Safety Data Sheet

WHMIS (Pictograms)	WHMIS (Classification)	Protective Clothing	TDG (pictograms)
	<b>Not controlled</b>		

<b>Section 1. Chemical Product and Company Identification</b>	
<b>Product Name</b>	<b>DRILL ROD HEAVY GREASE</b>
<b>Synonym</b>	Not available.
<b>Manufacturer</b>	PETRO-CANADA P.O. Box 2844 Calgary, Alberta T2P 3E3
<b>Material Uses</b>	This product is recommended for the lubrication of diamond drill rods.
<b>Code</b>	650-265, DRODH
<b>DSL</b>	See Section 15
<b>TSCA</b>	See Section 15
<b>In case of Emergency</b>	Petro-Canada: 403-296-3000 Canutec Transportation: 613-996-6666 Poison Control Centre: Consult local telephone directory for emergency number(s).

<b>Section 2. Composition and Information on Ingredients</b>					
			<i>Exposure Limits (ACGIH)</i>		
Name	CAS #	% (W/W)	TLV-TWA(8 h)	STEL	CEILING
1) Mixture of severely hydrotreated and hydrocracked, and/or solvent-refined base oil (petroleum) and other proprietary, non-hazardous additives.	Mixture	100	5 mg/m <sup>3</sup> (oil mist)	10 mg/m <sup>3</sup> (oil mist)	Not established

<b>Section 3. Hazards Identification.</b>	
<b>Potential Health Effects</b>	Non irritating to slight transient irritation to skin and eyes, but no permanent damage. Relatively non-toxic via ingestion. This product has a low vapour pressure and is not expected to present an inhalation exposure at ambient conditions. Upon heating to high temperatures, or mechanical actions which may produce vapours or mists, inhalation of product may cause irritation of the breathing passages. For more information, refer to Section 11.

<b>Section 4. First Aid Measures</b>	
<b>Eye Contact</b>	IMMEDIATELY flush eyes with running water for at least 15 minutes, keeping eyelids open. Seek medical attention.
<b>Skin Contact</b>	Remove contaminated clothing - launder before reuse. Wash gently and thoroughly the contaminated skin with running water and non-abrasive soap. High pressure grease gun is capable of injecting grease through the skin. Grease gun injuries require immediate physician assessment. Seek medical attention.
<b>Inhalation</b>	Evacuate the victim to a safe area as soon as possible. If the victim is not breathing, perform artificial respiration. Allow the victim to rest in a well ventilated area. Seek medical attention.
<b>Ingestion</b>	DO NOT induce vomiting because of danger of aspirating liquid into lungs. Seek medical attention.
<b>Note to Physician</b>	Not available

<b>Section 5. Fire-fighting Measures</b>			
<b>Flammability</b>	May be combustible at high temperature.	<b>Flammable Limits</b>	Not available.
<b>Flash Points</b>	Mineral Oil Blend: OPEN CUP: 252°C (485.6°F). (Cleveland).	<b>Auto-Ignition Temperature</b>	Not available.
<b>Fire Hazards in Presence of Various Substances</b>	Low fire hazard. This material must be heated before ignition will occur.	<b>Explosion Hazards in Presence of Various Substances</b>	Containers may explode in heat of fire. Do not cut, weld, heat, drill or pressurize empty container.
<b>Products of Combustion</b>	Carbon oxides (CO, CO <sub>2</sub> ), smoke and irritating vapours as products of incomplete combustion.		
<b>Fire Fighting Media and Instructions</b>	NAERG96, GUIDE 171, Substances (low to moderate hazard). If tank, rail car or tank truck is involved in a fire, ISOLATE for 800 meters (0.5 mile) in all directions; also, consider initial evacuation for 800 meters (0.5 mile) in all directions. Shut off fuel to fire if it is possible to do so without hazard. If this is impossible, withdraw from area and let fire burn out under controlled conditions. Withdraw immediately in case of rising sound from venting safety device or any discolouration of tank due to fire. Cool containing vessels with water spray in order to prevent pressure build-up, autoignition or explosion. SMALL FIRE: use DRY chemicals, foam, water spray or CO <sub>2</sub> . LARGE FIRE: use water spray, fog or foam. For small outdoor fires, portable fire extinguishers may be used, and self contained breathing apparatus (SCBA) may not be required. For all indoor fires and any significant outdoor fires, SCBA is required. Respiratory and eye protection are required for fire fighting personnel.		

**Section 6. Accidental Release Measures**

<b>Material Release or Spill</b>	Consult current National Emergency Response Guide Book (NAERG) for appropriate spill measures if necessary. Extinguish all ignition sources. Stop leak if safe to do so. Dike spilled material. Use appropriate inert absorbent material to absorb spilled product. Collect used absorbent for later disposal. Avoid contact with spilled material. Avoid contaminating sewers, streams, rivers and other water courses with spilled material. Notify appropriate authorities immediately.
----------------------------------	--

**Section 7. Handling and Storage**

<b>Handling</b>	Avoid contact with any sources of ignition, flames, heat, and sparks. Avoid skin contact. Avoid eye contact. Avoid inhalation of product vapours or mists. Empty containers may contain product residue. Do not pressurize, cut, heat, or weld empty containers. Do not reuse containers without commercial cleaning and/or reconditioning. Personnel who handle this material should practice good personal hygiene during and after handling to help prevent accidental ingestion of this product. Properly dispose of contaminated leather articles including shoes that cannot be decontaminated.
<b>Storage</b>	Store in dry, cool, well-ventilated area. Keep container tightly closed. Store away from incompatible and reactive materials (See section 5 and 10).

**Section 8. Exposure Controls/Personal Protection**

<b>Engineering Controls</b>	For normal application, special ventilation is not necessary. If user's operations generate vapours or mist, use ventilation to keep exposure to airborne contaminants below the exposure limit. Make-up air should always be supplied to balance air removed by exhaust ventilation. Ensure that eyewash station and safety shower are close to work-station.
<b>Personal Protection - The selection of personal protective equipment varies, depending upon conditions of use.</b>	
<b>Eyes</b>	Eye protection (i.e., safety glasses, safety goggles and/or face shield) should be determined based on conditions of use. If product is used in an application where splashing may occur, the use of safety goggles and/or a face shield should be considered.
<b>Body</b>	Wear appropriate clothing to prevent skin contact. As a minimum long sleeves and trousers should be worn.
<b>Respiratory</b>	Where concentrations in air may exceed the occupational exposure limits given in Section 2 (and those applicable to your area) and where engineering, work practices or other means of exposure reduction are not adequate, NIOSH approved respirators may be necessary to prevent overexposure by inhalation.
<b>Hands</b>	Wear appropriate chemically protective gloves. When handling hot product ensure gloves are heat resistant and insulated.
<b>Feet</b>	Wear appropriate footwear to prevent product from coming in contact with feet and skin.
<b>Exposure Limits</b>	Consult local, state, provincial or territory authorities for acceptable exposure limits. This product is not expected to form a mist based on its properties and expected use.

**Section 9. Physical and Chemical Properties**

<b>Physical State and Appearance</b>	Paste of long fibred texture.	<b>Viscosity</b>	Mineral Oil Blend: 155.5 cSt @ 40°C (104°F), 14.42 cSt @ 100°C (212°F), VI=89
<b>Colour</b>	Dark greenish-brown	<b>Pour Point</b>	Mineral Oil Blend: -15°C (5°F)
<b>Odour</b>	Mild grease like.	<b>Softening Point</b>	Not available
<b>Odour Threshold</b>	Not available.	<b>Dropping Point</b>	201°C (394°F)
<b>Boiling Point</b>	Not available.	<b>Penetration</b>	234 (60 strokes)
<b>Specific Gravity</b>	Mineral Oil Blend: 0.8898 kg/L @ 15°C (59°F).	<b>Oil / Water Dist. Coeff.</b>	Not available.
<b>Vapor Density</b>	Not available.	<b>Ionicity (in water)</b>	Not available
<b>Vapor Pressure</b>	Negligible at ambient temperature and pressure.	<b>Dispersion Properties</b>	Not available.
<b>Volatility</b>	Non-volatile.	<b>Solubility</b>	Insoluble in water.

**Section 10. Stability and Reactivity**

<b>Corrosivity</b>	Not corrosive to copper.		
<b>Stability</b>	The product is stable under normal handling and storage conditions.	<b>Hazardous Polymerization</b>	Will not occur under normal working conditions.
<b>Incompatible Substances / Conditions to Avoid</b>	Reactive with oxidizing agents, acids and alkalis.	<b>Decomposition Products</b>	May release COx, NOx, SOx, diphenylamine, alkenes, smoke and irritating vapours when heated to decomposition.

**Section 11. Toxicological Information**

<b>Routes of Entry</b>	Skin contact, eye contact, inhalation and ingestion.
<b>Acute Lethality</b>	Based on toxicity of components. Acute oral toxicity (LD50): >5000 mg/kg (rat). Acute dermal toxicity (LD50): >2000 mg/kg (rabbit).
<b>Chronic or Other Toxic Effects</b>	
Dermal Route:	Prolonged or repeated contact may cause skin irritation characterized by dermatitis or oil acne.
Inhalation Route:	Negligible breathing hazard at normal temperatures (up to 38°C) or recommended blending temperatures. Elevated temperatures or mechanical action may form vapours, mists or fumes. Inhalation of oil mists or vapours from hot oil may cause irritation of the upper respiratory tract.
Oral Route:	Low toxicity; has laxative effect.
Eye Irritation/Inflammation:	Repeated or prolonged contact may cause transient irritation, but no permanent damage.
Immunotoxicity:	Not available.
Skin Sensitization:	This product is not expected to be a skin sensitizer, based on the available data and the known hazards of the components.
Respiratory Tract Sensitization:	This product is not expected to be a respiratory tract sensitizer, based on the available data and the known hazards of the components.
Mutagenic:	Based on actual test results of base oils and results of similar products, severely hydrotreated base oils give negative results when tested for: (a) Salmonella Typhimurium TA98 using the Modified Ames Assay for Petroleum Product; (b) Salmonella-Escherichia coli/Mammalian-Microsome Reverse Mutation Assay (Ames test) with a Confirmatory Assay; (c) Structural Chromosomal Aberrations in Chinese Hamster Ovary (CHO) Cells.
Reproductive Toxicity:	This product is not expected to be a reproductive hazard, based on the available data and the known hazards of the components.
Teratogenicity/Embryotoxicity:	This product is not expected to be a teratogen or an embryotoxin, based on the available data and the known hazards of the components.
Carcinogenicity (ACGIH):	This product is not known to contain any chemicals at reportable quantities that are listed as A1 or A2 carcinogens by ACGIH.
Carcinogenicity (IARC):	This product is not known to contain any chemicals at reportable quantities that are listed as group 1, 2A or 2B carcinogens by IARC.
Carcinogenicity (NTP):	This product is not known to contain any chemicals at reportable quantities that are listed as carcinogens by NTP.
Carcinogenicity (IRIS):	Not available.
Carcinogenicity (OSHA):	This product is not known to contain any chemicals at reportable quantities that are listed as carcinogens by OSHA.
<b>Other Considerations</b>	No additional remark.

**Section 12. Ecological Information**

<b>Environmental Fate</b>	Not available.	<b>Persistence/ Bioaccumulation Potential</b>	Not available
<b>BOD5 and COD</b>	Not available.	<b>Products of Biodegradation</b>	Not available.
<b>Additional Remarks</b>	No additional remark.		

**Section 13. Disposal Considerations**

<b>Waste Disposal</b>	Spent/ used/ waste product may meet the requirements of a hazardous waste. Consult your local or regional authorities. Ensure that waste management processes are in compliance with government requirements and local disposal regulations.
-----------------------	--

**Section 14. Transport Information**

<b>TDG Classification</b>	Not controlled under TDG (Canada).	<b>Special Provisions for Transport</b>	Not applicable.
---------------------------	------------------------------------	---	-----------------

**Section 15. Regulatory Information**

**Other Regulations** This product is acceptable for use under the provisions of WHMIS-CPR. All components of this formulation are listed on the CEPA-DSL (Domestic Substances List).

All components of this formulation are listed on the US EPA-TSCA Inventory.

This product has been classified in accordance with the hazard criteria of the Controlled Products Regulations (CPR) and the MSDS contains all of the information required by the CPR.

Please contact Product Safety for more information.

**DSD/DPD (Europe)** Not evaluated.

<b>DSD/DPD (Europe) (Pictograms)</b>	NOT EVALUATED FOR EUROPEAN TRANSPORT NON ÉVALUÉ POUR LE TRANSPORT EUROPÉEN.	<b>DOT (U.S.A) (Pictograms)</b>	
--------------------------------------	--	---------------------------------	---

<b>HMIS (U.S.A.)</b>	<table border="1" style="border-collapse: collapse; width: 100%;"> <tr><td style="padding: 2px;">Health Hazard</td><td style="text-align: center; padding: 2px;">1</td></tr> <tr><td style="padding: 2px;">Fire Hazard</td><td style="text-align: center; padding: 2px;">1</td></tr> <tr><td style="padding: 2px;">Reactivity</td><td style="text-align: center; padding: 2px;">0</td></tr> <tr><td style="padding: 2px;">Personal Protection</td><td style="text-align: center; padding: 2px;">B</td></tr> </table>	Health Hazard	1	Fire Hazard	1	Reactivity	0	Personal Protection	B	<b>NFPA (U.S.A.)</b>	
Health Hazard	1										
Fire Hazard	1										
Reactivity	0										
Personal Protection	B										

**Section 16. Other Information**

**References** Available upon request.  
\* Marque de commerce de Petro-Canada - Trademark

**Glossary**

ACGIH - American Conference of Governmental Industrial Hygienists ADR - Agreement on Dangerous goods by Road (Europe) ASTM - American Society for Testing and Materials ( BOD5 - Biological Oxygen Demand in 5 days CAN/CGA B149.2 Propane Installation Code CAS - Chemical Abstract Services CEPA - Canadian Environmental Protection Act CERCLA - Comprehensive Environmental Response, Compensation and Liability Act CFR - Code of Federal Regulations CHIP - Chemicals Hazard Information and Packaging Approved Supply List COD5 - Chemical Oxygen Demand in 5 days CPR - Controlled Products Regulations DOT - Department of Transport DSCL - Dangerous Substances Classification and Labeling (Europe) DSD/DPD - Dangerous Substances or Dangerous Preparations Directives (Europe) DSL - Domestic Substance List EEC/EU - European Economic Community/European Union EINECS - European Inventory of Existing Commercial Chemical Substances EPCRA - Emergency Planning and Community Right to Know Act FDA - Food and Drug Administration FIFRA - Federal Insecticide, Fungicide and Rodenticide Act HCS - Hazardous Communication System HMIS - Hazardous Material Information System IARC - International Agency for Research on Cancer	IRIS - Integrated Risk Information System LD50/LC50 - Lethal Dose/Concentration kill 50% LDLo/LCLo - Lowest Published Lethal Dose/Concentration NAERG'96 - North American Emergency Response Guide Book (1996) NFPA - National Fire Prevention Association NIOSH - National Institute for Occupational Safety & Health NPRI - National Pollutant Release Inventory NSNR - New Substances Notification Regulations (Canada) NTP - National Toxicology Program OSHA - Occupational Safety & Health Administration PEL - Permissible Exposure Limit RCRA - Resource Conservation and Recovery Act SARA - Superfund Amendments and Reorganization Act SD - Single Dose STEL - Short Term Exposure Limit (15 minutes) TDG - Transportation Dangerous Goods (Canada) TDLo/TCLo - Lowest Published Toxic Dose/Concentration TLm - Median Tolerance Limit TLV-TWA - Threshold Limit Value-Time Weighted Average TSCA - Toxic Substances Control Act USEPA - United States Environmental Protection Agency USP - United States Pharmacopoeia WHMIS - Workplace Hazardous Material Information System
---	---

**Information Contact Internet: [www.petro-canada.ca](http://www.petro-canada.ca)**

**Lubricants:**  
**Western Canada, telephone: 1-800-661-1199; fax: (780) 464-9564**  
**Ontario & Central Canada, telephone: 1-800-268-5850 and (905) 822-4222; fax: 1-800-201-6285**  
**Quebec & Eastern Canada, telephone: 1-800-576-1686; fax: 800-201-6285**

**For Product Safety Information: (905) 804-4752**

**Prepared by Product Safety - JDW on 4/29/2003.**

**Data entry by Product Safety - JDW.**

*To the best of our knowledge, the information contained herein is accurate. However, neither the above named supplier nor any of its subsidiaries assumes any liability whatsoever for the accuracy or completeness of the information contained herein. Final determination of suitability of any material is the sole responsibility of the user. All materials may present unknown hazards and should be used with caution. Although certain hazards are described herein, we cannot guarantee that these are the only hazards that exist.*

**MATERIAL SAFETY DATA SHEET**

---

Date Prepared: November 14, 2003  
Supersedes: April 12, 2001  
MSDS Number: 12232

---

**1. PRODUCT INFORMATION**

Product Identifier: EPIC EP MOLY GREASE

Application and Use:  
Lubricating grease

Product Description:

A grease, a mixture of lubricating oil, soap and additives.

---

**REGULATORY CLASSIFICATION**

WHMIS:

Not a controlled product

CEPA: CANADIAN ENVIRONMENTAL PROTECTION ACT

All components of this product are either on the Domestic Substances List (DSL), exempt, or have been notified under CEPA.

TDG INFORMATION (RAIL/ROAD):

Not Regulated in Canada.

Please be aware that other regulations may apply.

---

**TELEPHONE NUMBERS**

Emergency 24 hr. (519) 339-2145  
Technical Info. (800) 268-3183

**MANUFACTURER/SUPPLIER:**

IMPERIAL OIL  
Products Division  
111 St Clair Avenue West  
Toronto, Ontario  
M5W 1K3  
(416) 968-4441

---

**2. REGULATED COMPONENTS**

The following components are defined in accordance with sub-paragraph 13(a) (i) to (iv) or paragraph 14(a) of the Hazardous Products Act:

NAME	%	CAS #
Not applicable		

### 3. TYPICAL PHYSICAL & CHEMICAL PROPERTIES

Physical State: Liquid  
 Specific gravity: 0.930 at 15.6 deg C/15.6 deg C  
 Viscosity: >20.00 cSt at 40 deg C  
 Vapour Density: not available  
 Boiling Point: 249 deg C  
 Evaporation rate: 0.1 (1= n-butylacetate)  
 Solubility in water: NEGLIGIBLE  
 Freezing/Pour Point: 230 deg C DROP  
 Odour Threshold: not available  
 Vapour Pressure: <0.01 kPa at 20 deg C  
 Appearance/odour: Black paste, petroleum odour.

### 4. HEALTH HAZARD INFORMATION

#### NATURE OF HAZARD

##### INHALATION:

Negligible hazard at normal temperatures (up to 38 deg C).  
 Elevated temperatures or mechanical action may form vapours, mists or fumes which may be irritating to the eyes, nose, throat and lungs.  
 Avoid breathing vapours or mists.

##### EYE CONTACT:

Slightly irritating, but will not injure eye tissue.

##### SKIN CONTACT:

Low toxicity.  
 Frequent or prolonged contact may irritate the skin.  
 High pressure greasing equipment is capable of injecting grease under the skin which may have severe health consequences.

##### INGESTION:

Low toxicity.

##### ACUTE TOXICITY DATA:

Based on animal testing data from similar materials and products,

the acute toxicity of this product is expected to be:

Oral : LD50 > 5000 mg/kg (Rat)  
Dermal : LD50 > 3160 mg/kg (Rabbit)  
Inhalation : LC50 > 5000 mg/m3 (Rat)

**OCCUPATIONAL EXPOSURE LIMIT:**

**ACGIH recommends:**

For insoluble Molybdenum compounds, 10 mg/m3.  
For oil mists, 5 mg/m3.

Local regulated limits may vary.

---

## 5. FIRST AID MEASURES

**INHALATION:**

In case of adverse exposure to vapours, mists and/or fumes formed at elevated temperature, or by mechanical action, immediately remove the affected victim from exposure. Administer artificial respiration if breathing has stopped. Keep at rest. Call for prompt medical attention.

**EYE CONTACT:**

Flush eyes with large amounts of water until irritation subsides. If irritation persists, get medical attention.

**SKIN CONTACT:**

Flush with large amounts of water. Use soap if available. Remove severely contaminated clothing (including shoes) and launder before reuse. If irritation persists, seek medical attention. Consult a physician immediately if the material is injected under the skin from the misuse of high pressure greasing equipment.

**INGESTION:**

If swallowed, DO NOT induce vomiting. Keep at rest. Get prompt medical attention.

---

## 6. PREVENTIVE AND CORRECTIVE MEASURES

**PERSONAL PROTECTION:**

The selection of personal protective equipment varies, depending upon conditions of use. In open systems where contact is likely, wear safety goggles, chemical-resistant overalls, and chemically impervious gloves. Where only incidental contact is likely, wear safety glasses with side shields. No other special precautions are necessary provided skin/eye

contact is avoided.

Where concentrations in air may exceed the occupational exposure limits given in Section 4 and where engineering, work practices or other means of exposure reduction are not adequate, approved respirators may be necessary to prevent overexposure by inhalation.

#### **ENGINEERING CONTROLS:**

The use of local exhaust ventilation is recommended to control emissions near the source. Laboratory samples should be handled in a fumehood. Provide mechanical ventilation of confined spaces.

#### **HANDLING, STORAGE AND SHIPPING:**

Keep containers closed. Handle and open containers with care. Store in a cool, well ventilated place away from incompatible materials. In keeping with good personal hygiene practices, wash hands thoroughly after handling the material. Empty containers may contain product residue. Do not pressurize cut, heat, or weld empty containers. Do not reuse empty containers without commercial cleaning or reconditioning.

#### **LAND SPILL:**

Eliminate source of ignition. Keep public away. Prevent additional discharge of material, if possible to do so without hazard. Prevent spills from entering sewers, watercourses or low areas. Contain spilled liquid with sand or earth. Allow material to solidify and scrape up. Place material in suitable containers for recycle or disposal. Consult an expert on disposal of recovered material. Ensure disposal in compliance with government requirements and ensure conformity to local disposal regulations. Notify the appropriate authorities immediately. Take all additional action necessary to prevent and remedy the adverse effects of the spill.

#### **WATER SPILL:**

Remove from surface by skimming or with suitable absorbents. If allowed by local authorities and environmental agencies, sinking and/or suitable dispersants may be used in unconfined waters. Consult an expert on disposal of recovered material. Ensure disposal in compliance with government requirements and ensure conformity to local disposal regulations. Notify the appropriate authorities immediately. Take all additional action necessary to prevent and remedy the adverse effects of the spill.

---

## **7. FIRE AND EXPLOSION HAZARD**

Flashpoint and method: 145 deg C COC ASTM D92

Autoignition: NA Flammable Limits: LEL: NA UEL: NA

**GENERAL HAZARDS:**

Low Hazard; liquids may burn upon heating to temperatures at or above the flash point.  
Toxic gases will form upon combustion.

**FIRE FIGHTING:**

Use water spray to cool fire exposed surfaces and to protect personnel.  
Shut off fuel to fire.  
Use foam, dry chemical or water spray to extinguish fire.  
Respiratory and eye protection required for fire fighting personnel.  
Avoid spraying water directly into storage containers due to danger of boilover.  
A self-contained breathing apparatus (SCBA) should be used for all indoor fires and any significant outdoor fires. For small outdoor fires, which may easily be extinguished with a portable fire extinguisher, use of an SCBA may not be required.

**HAZARDOUS COMBUSTION PRODUCTS:**

Fumes, smoke, carbon monoxide, sulfur oxides, nitrogen oxides, phosphorus oxides, aldehydes and other decomposition products, in the case of incomplete combustion  
Various metal oxides

---

**8. REACTIVITY DATA**

**STABILITY:**

This product is stable. Hazardous polymerization will not occur.

**INCOMPATIBLE MATERIALS AND CONDITIONS TO AVOID:**

Strong oxidizing agents

**HAZARDOUS DECOMPOSITION:**

none

---

**9. NOTES**

All components of this product are listed on the U.S. TSCA inventory.

.

**REVISION SUMMARY:**

Since 12 April 2001, this MSDS has been revised in Section(s):

1

## 10. PREPARATION

Date Prepared: November 14, 2003  
Prepared by: Lubricants & Specialties  
IMPERIAL OIL  
Products Division  
111 St Clair Avenue West  
Toronto, Ontario  
M5W 1K3  
(800) 268-3183

---

CAUTION: " The information contained herein relates only to this product or material and may not be valid when used in combination with any other product or material or in any process. If the product is not to be used for a purpose or under conditions which are normal or reasonably foreseeable, this information cannot be relied upon as complete or applicable. For greater certainty, uses other than those described in Section 1 must be reviewed with the supplier. The information contained herein is based on the information available at the indicated date of preparation. This MSDS is for the use of Imperial Oil customers and their employees and agents only. Any further distribution of this MSDS by Imperial Oil customers is prohibited without the written consent of Imperial Oil."



<b>WHMIS (Pictograms)</b>	<b>WHMIS (Classification)</b>	<b>Protective Clothing</b>	<b>TDG (pictograms)</b>
	<b>B-2, D-2A, D-2B</b>		

<b>Section 1. Chemical Product and Company Identification</b>	
<b>Product Name</b>	<b>FUEL SYSTEM TREATMENT</b>
<b>Synonym</b>	Not available
<b>Manufacturer</b>	PETRO-CANADA P.O. Box 2844 Calgary, Alberta T2P 3E3
<b>Material Uses</b>	A fuel system treatment that cleans fuel systems to improve performance in gasoline engines.
<b>Code</b>	FST
<b>Validated on</b>	5/12/2004.
<b>In case of Emergency</b>	Petro-Canada: 403-296-3000 Canutec Transportation: 613-996-6666 Poison Control Centre: Consult local telephone directory for emergency number(s).

<b>Section 2. Composition and Information on Ingredients</b>					
			<i>Exposure Limits (ACGIH)</i>		
<b>Name</b>	<b>CAS #</b>	<b>% (W/W)</b>	<b>TLV-TWA(8 h)</b>	<b>STEL</b>	<b>CEILING</b>
1) Stoddard Solvent	8052-41-3	30-60%	100ppm	Not established	Not established
2) Isopropanol	67-63-0	30-60%	200ppm	400ppm	Not established
3) 1, 2, 4-Trimethylbenzene	95-63-6	0.01-0.1%	Not established	Not established	Not established
4) Xylene (mixed isomers)	1330-20-7	0.01-0.1%	100ppm	150ppm	Not established
<b>Manufacturer Recommendation</b>	Not applicable				
<b>Other Exposure Limits</b>	Consult local, state, provincial or territory authorities for acceptable exposure limits.				

<b>Section 3. Hazards Identification.</b>	
<b>Potential Health Effects</b>	Flammable liquid. Exercise caution when handling this material. Contact with this product may cause skin irritation. Inhalation of this product may cause respiratory tract irritation and Central Nervous System (CNS) Depression, symptoms of which may include; weakness, dizziness, slurred speech, drowsiness, unconsciousness and in cases of severe overexposure; coma and death. May cause teratogenicity/embryotoxicity. For more information refer to Section 11 of this MSDS.

<b>Section 4. First Aid Measures</b>	
<b>Eye Contact</b>	Quickly and gently blot or brush away chemical. Immediately flush the contaminated eye(s) with lukewarm, gently flowing water for 5 minutes or until the chemical is removed, while holding the eyelid(s) open. Obtain medical attention immediately.
<b>Skin Contact</b>	Quickly and gently, blot or brush away excess chemical. Wash gently and thoroughly with warm water and non-abrasive soap for 5 minutes or until the chemical is removed. Remove contaminated clothing, shoes, and leather goods (e.g. watchbands, belts, etc.). If breathing is stopped, trained personnel should begin artificial respiration (AR) or, if the heart has stopped, cardiopulmonary resuscitation (CPR) immediately. Immediately transport victim to an emergency care facility.
<b>Inhalation</b>	If breathing is stopped, trained personnel should begin artificial respiration (AR) or, if the heart has stopped, cardiopulmonary resuscitation (CPR) immediately. Immediately transport victim to an emergency care facility.
<b>Ingestion</b>	NEVER give anything by mouth if victim is rapidly losing consciousness, or is unconscious or convulsing. Have victim rinse mouth thoroughly with water. DO NOT INDUCE VOMITING. Have victim drink 240 to 300 mL (8 to 10 oz.) of water to dilute material in stomach. If vomiting occurs naturally, have victim lean forward to reduce risk of aspiration. If breathing is stopped, trained personnel should begin artificial respiration (AR) or, if the heart has stopped, cardiopulmonary resuscitation (CPR) immediately. Immediately transport victim to an emergency care facility.
<b>Note to Physician</b>	Not available

<b>Section 5. Fire-fighting Measures</b>	
<b>Flammability</b>	Flammable.
<b>Flash Points</b>	CLOSED CUP: 13°C (55.4°F) (TCC)
<b>Flammable Limits</b>	LOWER: 0.9% UPPER: 12%
<b>Auto-Ignition Temperature</b>	Unknown

<b>Fire Hazards in Presence of Various Substances</b>	Flammable in presence of open flames, sparks, and heat. Vapours are heavier than air and may travel considerable distance to sources of ignition and flash back. May accumulate in confined spaces.	<b>Explosion Hazards in Presence of Various Substances</b>	Do not cut, weld, heat, drill or pressurize empty container. Containers may explode in heat of fire. Vapours may form explosive mixtures with air. Sensitive to static discharge.
<b>Products of Combustion</b>	Carbon oxides (CO, CO <sub>2</sub> ), acrid smoke and irritating vapours as products of incomplete combustion.		
<b>Fire Fighting Media and Instructions</b>	<p>NAERG2000, GUIDE 128, Flammable liquids (Non-polar/Water-immiscible). CAUTION: This product has a moderate flash point above 40°C: Use of water spray when fighting fire may be inefficient.</p> <p>If tank, rail car or tank truck is involved in a fire, ISOLATE for 800 meters (1/2 mile) in all directions; also consider initial evacuation for 800 meters (1/2 mile) in all directions.</p> <p>SMALL FIRES: Dry chemical, CO<sub>2</sub>, water spray or regular foam. LARGE FIRES: Water spray, fog or regular foam. Do not use straight streams. Move containers from fire area if you can do it without risk. Fires Involving Tanks or Car/Trailer Loads: Fight fire from maximum distance or use unmanned hose holders or monitor nozzles.</p> <p>Cool containers with flooding quantities of water until well after fire is out. Withdraw immediately in case of rising sound from venting devices or any discolouration of tank. ALWAYS stay away from the ends of tanks. For massive fire, use unmanned hose holders or monitor nozzles; if this is impossible withdraw from area and let fire burn. Wear positive pressure self-contained breathing apparatus (SCBA). Structural firefighters' protective clothing will only provide limited protection.</p>		

### Section 6. Accidental Release Measures

<b>Material Release or Spill</b>	Evacuate non-essential personnel. Ventilate area. Ensure clean-up personnel wear appropriate personal protective equipment. If spilled in a confined space, ensure appropriate confined space entry protocols are followed. Extinguish all ignition sources. Stop leak if safe to do so. Avoid breathing vapours or mists of material. Avoid contact with spilled material. Use appropriate inert absorbent material to absorb spilled product. Do not use paper or other flammable materials to absorb product. Collect used absorbent for later disposal. Ground and bond all equipment used to clean up the spilled material, as it may be a static accumulator. Consult current National Emergency Response Guide Book (NAERG) for appropriate spill measures if necessary. Do not allow spilled material to enter sewer systems as vapours may accumulate and may cause an explosion/fire hazard. Avoid contaminating sewers, streams, rivers and other water courses with spilled material. Notify appropriate authorities immediately.
----------------------------------	---

### Section 7. Handling and Storage

<b>Handling</b>	FLAMMABLE MATERIAL. Handle with care. Avoid contact with any sources of ignition, flames, heat, and sparks. Ensure all equipment is grounded/bonded. Avoid contact with any incompatible or reactive materials. Wear proper personal protective equipment (See Section 8). Avoid confined spaces and areas with poor ventilation. Remove severely contaminated clothing. Properly dispose of contaminated leather articles including shoes that cannot be decontaminated. Exercise caution when washing/drying clothing contaminated with flammable materials. Avoid skin contact. Avoid eye contact. Avoid inhalation of product vapours or mists. Do not ingest this product. Avoid generating mists. Ensure container is securely closed when not in use. Personnel who handle this material should practice good personal hygiene during and after handling to help prevent accidental ingestion of this product. Empty containers may contain product residue. Do not pressurize, cut, heat, or weld empty containers. Do not reuse containers without commercial cleaning and/or reconditioning.
<b>Storage</b>	Store as flammable material. Store away from heat and sources of ignition. Avoid direct sunlight. Store away from incompatible and reactive materials (See section 5 and 10). Ensure the storage containers are grounded/bonded. Store in a dry, cool and well-ventilated area.

### Section 8. Exposure Controls/Personal Protection

<b>Engineering Controls</b>	For normal application, special ventilation is not necessary. If user's operations generate vapours or mist, use ventilation to keep exposure to airborne contaminants below the exposure limit. Make-up air should always be supplied to balance air removed by exhaust ventilation. Use explosion-proof ventilation equipment. Ensure that eyewash station and safety shower are close to work-station.
<b>Personal Protection - <i>The selection of personal protective equipment varies, depending upon conditions of use.</i></b>	
<b>Eyes</b>	Chemical splash goggles should be worn when handling this material.
<b>Body</b>	If this material may come into contact with the body during handling and use, we recommend wearing appropriate protective clothing to prevent contact with the skin. (Contact your PPE provider for more information).
<b>Respiratory</b>	A NIOSH-approved air-purifying respirator with an organic vapour cartridge or canister with particulate filter (R and/or P series) may be permissible under certain circumstances where airborne concentrations are expected to exceed exposure limits. Protection provided by air-purifying respirators is limited. Use a positive-pressure, air-supplied respirator or self contained breathing apparatus if there is any potential for uncontrolled release, exposure levels are unknown, or any other circumstances where air-purifying respirators may not provide adequate protection.
<b>Hands</b>	If this material may come in contact with the hands during handling and use, we recommend wearing gloves of the following material(s): Polyvinyl alcohol (PVA), or Fluoro-elastomer. Consult your PPE provider for breakthrough times and the specific glove that is best for you based on your use patterns.
<b>Feet</b>	Wear appropriate footwear to prevent product from coming in contact with feet and skin.

**Section 9. Physical and Chemical Properties**

<b>Physical State and Appearance</b>	Liquid.	<b>Viscosity</b>	Not available
<b>Colour</b>	Yellow.	<b>Pour Point</b>	Not applicable.
<b>Odour</b>	Alcohol like.	<b>Softening Point</b>	Not applicable.
<b>Odour Threshold</b>	Not available	<b>Dropping Point</b>	Not applicable.
<b>Boiling Point</b>	83°C (181.4°F)	<b>Penetration</b>	Not applicable.
<b>Density</b>	0.79 @ 15°C	<b>Oil / Water Dist. Coefficient</b>	Not available
<b>Vapour Density</b>	>1	<b>Ionicity (in water)</b>	Not available
<b>Vapour Pressure</b>	Not available Evaporation rate: <1 (Ether=1)	<b>Dispersion Properties</b>	Not available
<b>Volatility</b>	>95% (VOCs)	<b>Solubility</b>	Negligible.

**Section 10. Stability and Reactivity**

<b>Corrosivity</b>	Not available		
<b>Stability</b>	The product is stable under normal handling and storage conditions.	<b>Hazardous Polymerization</b>	Will not occur under normal working conditions.
<b>Incompatible Substances / Conditions to Avoid</b>	Reactive with oxidizing agents, peroxides, nitric acid, strong alkalis, strong mineral acids, and oleum.	<b>Decomposition Products</b>	May release COx, acrid smoke, and irritating vapours when heated to decomposition.

**Section 11. Toxicological Information**

<b>Routes of Entry</b>	Skin contact, eye contact, inhalation and ingestion.
<b>Acute Lethality</b>	<p>Acute toxicity information is not available for the product as a whole, therefore, data for the hazardous ingredient is provided below:</p> <p><u>Stoddard Solvent (8052-41-3):</u>          Acute Oral toxicity (LD50): &gt;5000 mg/kg (rat)          Acute Dermal toxicity (LD50): &gt;3000 mg/kg (rabbit)          Acute Inhalation toxicity (LC50): &gt;1300 ppm/4h (rat)</p> <p><u>Isopropanol (67-63-0):</u>          Acute Oral toxicity (LD50): 5000 mg/kg (rat)          Acute Dermal toxicity (LD50): 12,800 mg/kg (rabbit)          Acute Inhalation toxicity (LC50): 17,000 ppm/4h (rat)</p> <p><u>1, 2, 4-Trimethylbenzene (95-63-6):</u>          Acute Oral toxicity (LD50): 5000 mg/kg (rat)          Acute Inhalation toxicity (LC50): 18,000 mg/m<sup>3</sup>/4h (rat)</p> <p><u>Xylene (mixed isomers) (1330-20-7):</u>          Acute Oral toxicity (LD50): 1590 mg/kg (rat)          Acute Dermal toxicity (LD50): &gt;1,700 mg/kg (rabbit)          Acute Inhalation toxicity (LC50): 4785 ppm/4h (mouse)</p>
<b>Chronic or Other Toxic Effects</b>	<p><b>Dermal Route:</b> This product contains a component (at &gt;= 1%) that can cause skin irritation. Therefore, this product is considered to be a skin irritant.</p> <p><b>Inhalation Route:</b> Inhalation of this product may cause respiratory tract irritation. Inhalation of this product may cause Central Nervous System (CNS) Depression, symptoms of which may include; weakness, dizziness, slurred speech, drowsiness, unconsciousness and in cases of severe overexposure; coma and death. Frequent or prolonged inhalation of this product may lead to absorption of this product in harmful amounts which may have adverse effects on the: kidneys.</p> <p><b>Oral Route:</b> Ingestion of this product may cause gastro-intestinal irritation. Ingestion of this product may cause Central Nervous System (CNS) Depression, symptoms of which may include; weakness, dizziness, slurred speech, drowsiness, unconsciousness and in cases of severe overexposure; coma and death. Ingestion of this product may lead to aspiration of the liquid, especially if vomiting occurs. This may result in chemical pneumonitis (inflammation of the lungs) and/or pulmonary edema (an accumulation of fluid in the lungs).</p> <p><b>Eye Irritation/Inflammation:</b> This product contains a component (at &gt;= 1%) that can cause eye irritation. Therefore, this product is considered to be an eye irritant.</p> <p><b>Immunotoxicity:</b> Not available</p> <p><b>Skin Sensitization:</b> Contact with this product is not expected to cause skin sensitization, based upon the available data and the known hazards of the components.</p>

Respiratory Tract Sensitization:	Contact with this product is not expected to cause respiratory tract sensitization, based upon the available data and the known hazards of the components.
Mutagenic:	This product is not known to contain any components at >= 0.1% that have been shown to cause mutagenicity. Therefore, based upon the available data and the known hazards of the components, this product is not expected to be a mutagen.
Reproductive Toxicity:	This product is not known to contain any components at >= 0.1% that have been shown to cause reproductive toxicity. Therefore, based upon the available data and the known hazards of the components, this product is not expected to be a reproductive toxin.
Teratogenicity/Embryotoxicity:	This product contains a component(s) at >= 0.1% that has been shown to cause teratogenicity and/or embryotoxicity in some laboratory tests at non-maternally toxic doses. Therefore, this product is considered to be a teratogen/embryotoxin.
Carcinogenicity (ACGIH):	This product is not known to contain any chemicals at reportable quantities that are listed as Group A1, A2, or A3 carcinogens by ACGIH.
Carcinogenicity (IARC):	This product is not known to contain any chemicals at reportable quantities that are listed as Group 1, 2A, or 2B carcinogens by IARC.
Carcinogenicity (NTP):	This product is not known to contain any chemicals at reportable quantities that are listed as carcinogens by NTP.
Carcinogenicity (IRIS):	This product is not known to contain any chemicals at reportable quantities that are listed as carcinogens by IRIS.
Carcinogenicity (OSHA):	This product is not known to contain any chemicals at reportable quantities that are listed as carcinogens by OSHA.
<b>Other Considerations</b>	No additional remark.

<b>Section 12. Ecological Information</b>			
<b>Environmental Fate</b>	Not available	<b>Persistence/Bioaccumulation Potential</b>	Not available
<b>BOD5 and COD</b>	Not available	<b>Products of Biodegradation</b>	Not available
<b>Additional Remarks</b>	No additional remark.		

<b>Section 13. Disposal Considerations</b>	
<b>Waste Disposal</b>	Spent/ used/ waste product may meet the requirements of a hazardous waste. Consult your local or regional authorities. Ensure that waste management processes are in compliance with government requirements and local disposal regulations.

<b>Section 14. Transport Information</b>			
<b>TDG Classification</b>	FLAMMABLE LIQUIDS, N.O.S. (Isopropanol), Class 3, UN 1993, PGII (CL-TDG)	<b>Special Provisions for Transport</b>	This product may be shipped as a Limited Quantity if the volume is ≤1L and in accordance with the Limited Quantity Provisions, (CL-TDG).

<b>Section 15. Regulatory Information</b>																							
<b>Other Regulations</b>	<p>This product is acceptable for use under the provisions of WHMIS-CPR. All components of this formulation are listed on the CEPA-DSL (Domestic Substances List).</p> <p>This product has been classified in accordance with the hazard criteria of the Controlled Products Regulations (CPR) and the MSDS contains all of the information required by the CPR.</p> <p>Please contact Product Safety for more information.</p>																						
<b>DSD/DPD (Europe)</b>	Not evaluated.	<b>HCS (U.S.A.)</b>	CLASS: Combustible liquid. CLASS: Irritating substance. CLASS: Target organ effects.																				
<b>ADR (Europe) (Pictograms)</b>	NOT EVALUATED FOR EUROPEAN TRANSPORT NON ÉVALUÉ POUR LE TRANSPORT EUROPÉEN.	<b>DOT (U.S.A) (Pictograms)</b>																					
<b>HMIS (U.S.A.)</b>	<table border="1"> <tr> <td>Health Hazard</td> <td>2*</td> </tr> <tr> <td>Fire Hazard</td> <td>3</td> </tr> <tr> <td>Reactivity</td> <td>0</td> </tr> <tr> <td>Personal Protection</td> <td>n, p, u</td> </tr> </table>	Health Hazard	2*	Fire Hazard	3	Reactivity	0	Personal Protection	n, p, u	<b>NFPA (U.S.A.)</b>	<table border="1"> <tr> <td>Health</td> <td>2</td> <td>Fire Hazard</td> <td>3</td> </tr> <tr> <td></td> <td>0</td> <td>Reactivity</td> <td>0</td> </tr> <tr> <td></td> <td></td> <td>Specific hazard</td> <td></td> </tr> </table>	Health	2	Fire Hazard	3		0	Reactivity	0			Specific hazard	
Health Hazard	2*																						
Fire Hazard	3																						
Reactivity	0																						
Personal Protection	n, p, u																						
Health	2	Fire Hazard	3																				
	0	Reactivity	0																				
		Specific hazard																					
		<b>Rating</b>	0 Insignificant 1 Slight 2 Moderate 3 High 4 Extreme																				

**Section 16. Other Information**

**References** Available upon request.  
 \* Marque de commerce de Petro-Canada - Trademark

**Glossary**

ACGIH - American Conference of Governmental Industrial Hygienists	IRIS - Integrated Risk Information System
ADR - Agreement on Dangerous goods by Road (Europe)	LD50/LC50 - Lethal Dose/Concentration kill 50%
ASTM - American Society for Testing and Materials	LDLo/LCLo - Lowest Published Lethal Dose/Concentration
BOD5 - Biological Oxygen Demand in 5 days	NAERG'96 - North American Emergency Response Guide Book (1996)
CAN/CGA B149.2 Propane Installation Code	NFPA - National Fire Prevention Association
CAS - Chemical Abstract Services	NIOSH - National Institute for Occupational Safety & Health
CEPA - Canadian Environmental Protection Act	NPRI - National Pollutant Release Inventory
CERCLA - Comprehensive Environmental Response, Compensation and Liability Act	NSNR - New Substances Notification Regulations (Canada)
CFR - Code of Federal Regulations	NTP - National Toxicology Program
CHIP - Chemicals Hazard Information and Packaging Approved Supply List	OSHA - Occupational Safety & Health Administration
COD5 - Chemical Oxygen Demand in 5 days	PEL - Permissible Exposure Limit
CPR - Controlled Products Regulations	RCRA - Resource Conservation and Recovery Act
DOT - Department of Transport	SARA - Superfund Amendments and Reorganization Act
DSCL - Dangerous Substances Classification and Labeling (Europe)	SD - Single Dose
DSD/DPD - Dangerous Substances or Dangerous Preparations Directives (Europe)	STEL - Short Term Exposure Limit (15 minutes)
DSL - Domestic Substance List	TDG - Transportation Dangerous Goods (Canada)
EEC/EU - European Economic Community/European Union	TDL <sub>o</sub> /TCL <sub>o</sub> - Lowest Published Toxic Dose/Concentration
EINECS - European Inventory of Existing Commercial Chemical Substances	TL <sub>m</sub> - Median Tolerance Limit
EPCRA - Emergency Planning and Community Right to Know Act	TLV-TWA - Threshold Limit Value-Time Weighted Average
FDA - Food and Drug Administration	TSCA - Toxic Substances Control Act
FIFRA - Federal Insecticide, Fungicide and Rodenticide Act	USEPA - United States Environmental Protection Agency
HCS - Hazardous Communication System	USP - United States Pharmacopoeia
HMIS - Hazardous Material Information System	WHMIS - Workplace Hazardous Material Information System
IARC - International Agency for Research on Cancer	

**For Copy of MSDS**  
 Internet: [www.petro-canada.ca/msds](http://www.petro-canada.ca/msds)

Western Canada, Ontario & Central Canada, telephone: 1-800-668-0220; fax: 1-800-837-1228  
 Quebec & Eastern Canada, telephone: 514-640-8308; fax: 514-640-8385

**For Product Safety Information: (905) 804-4752**

Prepared by Product Safety - TLM on 5/12/2004.  
 Data entry by Product Safety - RS.

*To the best of our knowledge, the information contained herein is accurate. However, neither the above named supplier nor any of its subsidiaries assumes any liability whatsoever for the accuracy or completeness of the information contained herein. Final determination of suitability of any material is the sole responsibility of the user. All materials may present unknown hazards and should be used with caution. Although certain hazards are described herein, we cannot guarantee that these are the only hazards that exist.*



# Material Safety Data Sheet

<b>WHMIS (Pictograms)</b>	<b>WHMIS (Classification)</b>	<b>Protective Clothing</b>	<b>TDG (pictograms)</b>
	<b>B-2, D-2A, D-2B</b>		

<b>Section 1. Chemical Product and Company Identification</b>	
<b>Product Name</b> <b>GASOLINE, UNLEADED</b>	<b>Code</b> W102E
<b>Synonym</b> Regular, Unleaded Gasoline (US Grade), Mid-Grade, Plus, Super, WinterGas, SummerGas, Supreme, SuperClean WinterGas, RegularClean, PlusClean, Premium, marked or dyed gasoline, Super Premium (94 RO)	<b>Validated on</b> 6/9/2004.
<b>Manufacturer</b> PETRO-CANADA P.O. Box 2844 Calgary, Alberta T2P 3E3	<b>In case of Emergency</b> Petro-Canada: 403-296-3000 Canutec Transportation: 613-996-6666 Poison Control Centre: Consult local telephone directory for emergency number(s).
<b>Material Uses</b> Unleaded gasoline is used in spark ignition engines including motor vehicles, inboard and outboard boat engines, small engines such as chain saws and lawn mowers, and recreational vehicles.	

<b>Section 2. Composition and Information on Ingredients</b>					
			<i>Exposure Limits (ACGIH)</i>		
<b>Name</b>	<b>CAS #</b>	<b>% (V/V)</b>	<b>TLV-TWA(8 h)</b>	<b>STEL</b>	<b>CEILING</b>
Gasoline	8006-61-9	85-100	300 ppm (890 mg/m <sup>3</sup> )	500 ppm (1480 mg/m <sup>3</sup> )	Not established
Methyl tert-butyl ether	1634-04-4	0-15	40 ppm (144mg/m <sup>3</sup> )	Not established	Not established
Note: Petro-Canada does not use MTBE in the manufacturing of its gasoline, however MTBE can be introduced from time to time through the use of external gasoline blendstocks.					
<b>Manufacturer Recommendation</b>	Not applicable				
<b>Other Exposure Limits</b>	Consult local, state, provincial or territory authorities for acceptable exposure limits.				

<b>Section 3. Hazards Identification.</b>	
<b>Potential Health Effects</b>	Possible cancer hazard. Inhalation of vapours can be irritating to respiratory tract and cause CNS depression with symptoms of nausea, headaches, vomiting, dizziness, fatigue, light-headedness, reduced coordination, unconsciousness and possibly death. Skin and eye contact can cause irritation. Toxic if ingested. For more information, refer to Section 11.

<b>Section 4. First Aid Measures</b>	
<b>Eye Contact</b>	IMMEDIATELY flush eyes with running water for at least 15 minutes, keeping eyelids open. Seek medical attention if irritation persists.
<b>Skin Contact</b>	Remove contaminated clothing - launder before reuse. Wash gently and thoroughly the contaminated skin with running water and non-abrasive soap. Seek medical attention.
<b>Inhalation</b>	Evacuate the victim to a safe area as soon as possible. If the victim is not breathing, perform artificial respiration. Allow the victim to rest in a well ventilated area. Seek medical attention.
<b>Ingestion</b>	DO NOT induce vomiting because of danger of aspirating liquid into lungs. Seek medical attention.
<b>Note to Physician</b>	Not available

**Section 5. Fire-fighting Measures**

<b>Flammability</b>	Flammable liquid (NFPA).	<b>Flammable Limits</b>	Lower: 1.3%; Upper: 7.6% (NFPA).
<b>Flash Points</b>	Closed Cup: -50 to -38°C (-58 to -36°F), ASTM D56 Standard Test Method for Flash Point by Tag Closed Tester.	<b>Auto-Ignition Temperature</b>	257°C (495°F) (NFPA).
<b>Fire Hazards in Presence of Various Substances</b>	Extremely flammable in presence of open flames, sparks, and heat. Vapours are heavier than air and may travel considerable distance to sources of ignition and flash back. Rapid escape of vapour may generate static charge causing ignition.	<b>Explosion Hazards in Presence of Various Substances</b>	Do not cut, weld, heat, drill or pressurize empty container. Containers may explode in heat of fire. Vapours may form explosive mixtures with air.
<b>Products of Combustion</b>	Carbon oxides (CO, CO <sub>2</sub> ), nitrogen oxides (NO <sub>x</sub> ), polynuclear aromatic hydrocarbons, phenols, smoke and irritating vapours as products of incomplete combustion.		
<b>Fire Fighting Media and Instructions</b>	NAERG96, GUIDE 128, flammable/combustible liquid (non-polar/water-immiscible). CAUTION: This product has a very low flash point, use of water spray when fighting fire may be inefficient. SMALL FIRE: Use DRY chemicals, CO <sub>2</sub> , water spray or foam. LARGE FIRE: Use water spray, fog or foam. DO NOT use water jet. If tank, rail car or tank truck is involved in a fire, ISOLATE for 1600 meters (1 mile) in all directions; also, consider initial evacuation for 1600 meters (1 mile) in all directions. DO NOT extinguish a leaking gas flame unless leak can be stopped. Shut off fuel to fire if it is possible to do so without hazard. If this is impossible, withdraw from area and let fire burn out under controlled conditions. Withdraw immediately in case of rising sound from venting safety device or any discolouration of tank due to fire. Cool containing vessels with water spray in order to prevent pressure build-up, autoignition or explosion. Avoid flushing spilled material into sewers, streams or other bodies of water. Self-contained breathing apparatus (SCBA) will be required if approaching the fire from downwind, or to enter enclosed areas or buildings.		

**Section 6. Accidental Release Measures**

<b>Material Release or Spill</b>	NAERG96, GUIDE 128, flammable/combustible liquid (non-polar/water-immiscible). Evacuate in a downwind direction for at least 300 meters (1000 feet). ELIMINATE ALL IGNITION SOURCES. Ventilate closed spaces before entering. By forced ventilation, maintain concentration of vapour below the range of explosive mixture. Avoid contact, fully-encapsulating, vapour-protective clothing should be worn for spills and leaks with no fire. Stop leak if without risk. Use vapour suppressing foam or water spray to reduce vapours; it may reduce vapour, but it may not prevent ignition in closed spaces; isolate area until vapour has dispersed. Contain spill. Absorb with inert absorbents such as dry clay, or diatomaceous earth, or recover using electrically grounded explosion-proof pumps. Avoid inhaling dust of diatomaceous earth for it may contain silica (very fine particle size), making this a potential respiratory hazard. Place used absorbent in closed metal containers for later disposal or burn absorbent in a suitable combustion chamber. DO NOT FLUSH TO SEWERS, STREAMS OR OTHER BODIES OF WATER. Check with applicable jurisdiction for specific disposal requirements of spilled material and empty containers. Notify the appropriate authorities immediately.
----------------------------------	---

**Section 7. Handling and Storage**

<b>Handling</b>	Keep away from heat, spark and other sources of ignition. Empty container may contain flammable/explosive residues or vapours. DO NOT reuse empty containers without commercial cleaning or reconditioning. Ground/bond line and equipment during pumping or transfer to avoid accumulation of static charge. DO NOT USE AS CLEANING FLUID OR SIPHON BY MOUTH. Wear proper protective equipment. Avoid inhalation and contact with skin or eyes. Practice good personal hygiene. Wash hands after handling and before eating. Launder work clothes frequently. Discard saturated leather goods.
<b>Storage</b>	Store in cool, dry, isolated, well-ventilated area, and away from direct sunlight, sources of ignition and incompatibles. Flammable materials should be stored in a separate safety storage cabinet or room. Ground all equipment containing material.

**Section 8. Exposure Controls/Personal Protection**

<b>Engineering Controls</b>	For normal application, special ventilation is not necessary. If user's operations generate vapours or mist, use ventilation to keep exposure to airborne contaminants below the exposure limit. Make-up air should always be supplied to balance air removed by exhaust ventilation. Ensure that eyewash station and safety shower are close to work-station.
<b>Personal Protection - The selection of personal protective equipment varies, depending upon conditions of use.</b>	
<b>Eyes</b>	Eye protection (i.e., safety glasses, safety goggles and/or face shield) should be determined based on conditions of use. If product is used in an application where splashing may occur, the use of safety goggles and/or a face shield should be considered.
<b>Body</b>	Wear appropriate clothing to prevent skin contact. As a minimum long sleeves and trousers should be worn.

**Respiratory** Where concentrations in air may exceed the occupational exposure limits given in Section 2 (and those applicable to your area) and where engineering, work practices or other means of exposure reduction are not adequate, NIOSH approved respirators may be necessary to prevent overexposure by inhalation.

**Hands** Wear appropriate chemically protective gloves. When handling hot product ensure gloves are heat resistant and insulated.

**Feet** Wear appropriate footwear to prevent product from coming in contact with feet and skin.

### Section 9. Physical and Chemical Properties

<b>Physical State and Appearance</b>	Clear liquid.	<b>Viscosity</b>	Not available
<b>Colour</b>	Clear to slightly yellow, undyed liquid. May be dyed red for taxation purposes.	<b>Pour Point</b>	Not applicable.
<b>Odour</b>	Gasoline. MTBE has a terpene-like odour.	<b>Softening Point</b>	Not applicable.
<b>Odour Threshold</b>	Less than 1 ppm.	<b>Dropping Point</b>	Not applicable.
<b>Boiling Point</b>	25 to 220°C (77 to 428°F) Initial boiling point by ASTM D86 Standard Test Method.	<b>Penetration</b>	Not applicable.
<b>Density</b>	0.7 kg/L @ 15°C (59°F).	<b>Oil / Water Dist. Coefficient</b>	Not available
<b>Vapour Density</b>	3 to 4 (Air = 1) (NFPA).	<b>Ionicity (in water)</b>	Insoluble in water.
<b>Vapour Pressure</b>	<107 kPa @ 37.8°C (100°F)	<b>Dispersion Properties</b>	Not available
<b>Volatility</b>	Volatile.	<b>Solubility</b>	Hydrocarbon components virtually insoluble in water. Soluble in alcohol, ether, chloroform, and benzene. Dissolves fats, oils and natural resins.

### Section 10. Stability and Reactivity

<b>Corrosivity</b>	Non corrosive.		
<b>Stability</b>	The product is stable under normal handling and storage conditions.	<b>Hazardous Polymerization</b>	Will not occur under normal working conditions.
<b>Incompatible Substances / Conditions to Avoid</b>	Reactive with oxidizing agents, acids.	<b>Decomposition Products</b>	May release COx, NOx, phenols, polynuclear aromatic hydrocarbons, smoke and irritating vapours when heated to decomposition.

### Section 11. Toxicological Information

<b>Routes of Entry</b>	Skin contact, eye contact, inhalation, and ingestion.		
<b>Acute Lethality</b>	<p>Gasoline: Acute oral toxicity (LD50): 13 600 mg/kg (rat).          Acute dermal toxicity (LD50): &gt;5000 mg/kg (rabbit).          Acute inhalation toxicity (LC50): &gt;300 000 mg/m<sup>3</sup>/4h (rat).</p> <p>MTBE: Acute oral toxicity (LD50): 29630 mg/kg (rat).          Acute dermal toxicity (LD50): &gt;6800 mg/kg (rabbit).          Acute inhalation toxicity (LC50): 23 576 ppm/4h (rat).</p>		
<b>Chronic or Other Toxic Effects</b>	<p><b>Dermal Route:</b> This product can cause skin irritation. Prolonged or repeated contact with skin may cause dermatitis.</p> <p><b>Inhalation Route:</b> Inhalation of vapours can be irritating to respiratory tract and cause CNS depression with symptoms of nausea, headaches, vomiting, dizziness, fatigue, light-headedness, reduced coordination, unconsciousness and possibly death.</p> <p><b>Oral Route:</b> Swallowing or vomiting of the liquid may result in aspiration into the lungs. Can cause CNS depression. (See Inhalation Route for symptoms).</p> <p><b>Eye Irritation/Inflammation:</b> Can cause irritation to the eyes.</p> <p><b>Immunotoxicity:</b> Not available</p>		

Skin Sensitization:	This product is not expected to be a skin sensitizer, based on the available data and the known hazards of the components.
Respiratory Tract Sensitization:	This product is not expected to be a respiratory tract sensitizer, based on the available data and the known hazards of the components.
Mutagenic:	This product is not considered to be a mutagen, based on the available data and the known hazards of the components.
Reproductive Toxicity:	This product is not considered to be a reproductive hazard, based on the available data and the known hazards of the components.
Teratogenicity/Embryotoxicity:	This product is not considered to be a teratogen or an embryotoxin, based on the available data and the known hazards of the components.
Carcinogenicity (ACGIH):	ACGIH A3: animal carcinogen. [Gasoline, MTBE]
Carcinogenicity (IARC):	IARC Group 2B: possibly carcinogenic to humans. [Gasoline]
Carcinogenicity (NTP):	This product is not known to contain any chemicals at reportable quantities that are listed as carcinogens by NTP.
Carcinogenicity (IRIS):	Not available
Carcinogenicity (OSHA):	This product is not known to contain any chemicals at reportable quantities that are listed as carcinogens by OSHA.
<b>Other Considerations</b>	Unleaded gasoline caused kidney effects in male rats and liver effects in female mice.

**Section 12. Ecological Information**

<b>Environmental Fate</b>	Not available	<b>Persistence/Bioaccumulation Potential</b>	Not available
<b>BOD5 and COD</b>	Not available	<b>Products of Biodegradation</b>	Not available
<b>Additional Remarks</b>	Not available		

**Section 13. Disposal Considerations**

<b>Waste Disposal</b>	Preferred waste management priorities are: (1) recycle or reprocess; (2) incineration with energy recovery; (3) disposal at licensed waste disposal facility. Ensure that disposal or reprocessing is in compliance with government requirements and local disposal regulations. Consult your local or regional authorities.
-----------------------	--

**Section 14. Transport Information**

<b>TDG Classification</b>	GASOLINE, 3, UN1203, PGII (CL-TDG)	<b>Special Provisions for Transport</b>	See Transportation of Dangerous Goods Regulations.
---------------------------	------------------------------------	---	--

**Section 15. Regulatory Information**

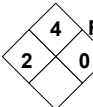
<b>Other Regulations</b>	CEPA: This product is acceptable for use under the provisions of WHMIS-CPR. All components of this formulation are listed on the CEPA-DSL (Domestic Substances List). EPA: All components of this formulation are listed on the US EPA-TSCA Inventory.  This product has been classified in accordance with the hazard criteria of the Controlled Products Regulations (CPR) and the MSDS contains all of the information required by the CPR. Please contact Product Safety for more information.		
<b>DSD/DPD (Europe)</b>	Not evaluated.	<b>HCS (U.S.A.)</b>	CLASS: Contains material which may cause cancer. CLASS: Flammable liquid having a flash point lower than 37.8°C (100°F). CLASS: Irritating substance. CLASS: Target organ effects.
<b>ADR (Europe) (Pictograms)</b>	NOT EVALUATED FOR EUROPEAN TRANSPORT NON ÉVALUÉ POUR LE TRANSPORT EUROPÉEN.	<b>DOT (U.S.A) (Pictograms)</b>	
<b>HMIS (U.S.A.)</b>	Health Hazard (2*) Fire Hazard (4) Reactivity (0)	<b>NFPA (U.S.A.)</b>	Rating 0 Insignificant 1 Slight 2 Moderate
			Fire Hazard Reactivity

Personal Protection (H)

Specific hazard

3 High

4 Extreme

**Section 16. Other Information****References**

Available upon request.

\* Marque de commerce de Petro-Canada - Trademark

**Glossary**

ACGIH - American Conference of Governmental Industrial Hygienists  
 ADR - Agreement on Dangerous goods by Road (Europe)  
 ASTM - American Society for Testing and Materials  
 BOD5 - Biological Oxygen Demand in 5 days  
 CAN/CGA B149.2 Propane Installation Code  
 CAS - Chemical Abstract Services  
 CEPA - Canadian Environmental Protection Act  
 CERCLA - Comprehensive Environmental Response, Compensation and Liability Act  
 CFR - Code of Federal Regulations  
 CHIP - Chemicals Hazard Information and Packaging Approved Supply List  
 COD5 - Chemical Oxygen Demand in 5 days  
 CPR - Controlled Products Regulations  
 DOT - Department of Transport  
 DSCL - Dangerous Substances Classification and Labeling (Europe)  
 DSD/DPD - Dangerous Substances or Dangerous Preparations Directives (Europe)  
 DSL - Domestic Substance List  
 EEC/EU - European Economic Community/European Union  
 EINECS - European Inventory of Existing Commercial Chemical Substances  
 EPCRA - Emergency Planning and Community Right to Know Act  
 FDA - Food and Drug Administration  
 FIFRA - Federal Insecticide, Fungicide and Rodenticide Act  
 HCS - Hazardous Communication System  
 HMIS - Hazardous Material Information System  
 IARC - International Agency for Research on Cancer

IRIS - Integrated Risk Information System  
 LD50/LC50 - Lethal Dose/Concentration kill 50%  
 LDLo/LCLo - Lowest Published Lethal Dose/Concentration  
 NAERG'96 - North American Emergency Response Guide Book (1996)  
 NFPA - National Fire Prevention Association  
 NIOSH - National Institute for Occupational Safety & Health  
 NPRI - National Pollutant Release Inventory  
 NSNR - New Substances Notification Regulations (Canada)  
 NTP - National Toxicology Program  
 OSHA - Occupational Safety & Health Administration  
 PEL - Permissible Exposure Limit  
 RCRA - Resource Conservation and Recovery Act  
 SARA - Superfund Amendments and Reorganization Act  
 SD - Single Dose  
 STEL - Short Term Exposure Limit (15 minutes)  
 TDG - Transportation Dangerous Goods (Canada)  
 TDLo/TCLo - Lowest Published Toxic Dose/Concentration  
 TLM - Median Tolerance Limit  
 TLV-TWA - Threshold Limit Value-Time Weighted Average  
 TSCA - Toxic Substances Control Act  
 USEPA - United States Environmental Protection Agency  
 USP - United States Pharmacopoeia  
 WHMIS - Workplace Hazardous Material Information System

**For Copy of MSDS****Fuels & Solvents:**

Western Canada, telephone: 403-296-4158; fax: 403-296-6551

Ontario &amp; Central Canada, telephone: 1-800-668-0220; fax: 1-800-837-1228

Quebec &amp; Eastern Canada, telephone: 514-640-8308; fax: 514-640-8385

**For Product Safety Information: (905) 804-4752**

Prepared by Product Safety - JDW on 6/9/2004.

Data entry by Product Safety - RS.

***To the best of our knowledge, the information contained herein is accurate. However, neither the above named supplier nor any of its subsidiaries assumes any liability whatsoever for the accuracy or completeness of the information contained herein. Final determination of suitability of any material is the sole responsibility of the user. All materials may present unknown hazards and should be used with caution. Although certain hazards are described herein, we cannot guarantee that these are the only hazards that exist.***



<b>WHMIS (Pictograms)</b>	<b>WHMIS (Classification)</b>	<b>Protective Clothing</b>	<b>TDG (pictograms)</b>
	<b>B-2, D-2A, D-2B</b>		

<b>Section 1. Chemical Product and Company Identification</b>	
<b>Product Name</b>	<b>JET B AVIATION TURBINE FUEL</b>
<b>Synonym</b>	Jet B; Jet B DI; JP-4; Jet F-40; NATO F-40; Turbine Fuel, Aviation, Wide Cut Type (CAN/CGSB-3.22).
<b>Manufacturer</b>	PETRO-CANADA P.O. Box 2844 Calgary, Alberta T2P 3E3
<b>Material Uses</b>	Used as aviation turbine fuel. May contain a fuel system icing inhibitor.
<b>Code</b>	W219 SAP: 150, 151, 152
<b>Validated on</b>	12/3/2001.
<b>In case of Emergency</b>	Petro-Canada: 403-296-3000 Canutec Transportation: 613-996-6666 Poison Control Centre: Consult local telephone directory for emergency number(s).

<b>Section 2. Composition and Information on Ingredients</b>					
Name	CAS #	% (V/V)	Exposure Limits (ACGIH)		
			TLV-TWA(8 h)	STEL	CEILING
1) Complex mixture of petroleum hydrocarbons (C6-C14).	64741-41-9	>99	Not established	Not established	Not established
2) Benzene	71-43-2	<0.5	0.5 ppm	2.5 ppm	Not established
3) Fuel System Icing Inhibitor (FSII) (if added*): Diethylene Glycol Monomethyl Ether	111-77-3	≤0.15	Not established	Not established	Not established
4) Anti-static, antioxidant and metal deactivator additives.	Not applicable	<0.1	Not applicable	Not applicable	Not applicable
* Please note that Jet B DI, JP-4, Jet F-40 and NATO F-40 all contain Fuel System Icing Inhibitor (FSII).					
<b>Manufacturer Recommendation</b>	Not applicable				
<b>Other Exposure Limits</b>	Consult local, state, provincial or territory authorities for acceptable exposure limits.				

<b>Section 3. Hazards Identification.</b>	
<b>Potential Health Effects</b>	Skin and eye contact can cause irritation. Inhalation of vapours can cause irritation of the respiratory tract and CNS depression with symptoms of nausea, headaches, vomiting, dizziness, fatigue, light-headedness, reduced coordination, unconsciousness and possibly death. Aspiration into the lungs may produce potentially fatal chemical pneumonitis (fluid in the lungs), severe lung damage, or respiratory failure. This product contains a cancer causing agent. For more information, refer to Section 11.

<b>Section 4. First Aid Measures</b>	
<b>Eye Contact</b>	IMMEDIATELY flush eyes with running water for at least 15 minutes, keeping eyelids open. Seek medical attention.
<b>Skin Contact</b>	Remove contaminated clothing - launder before reuse. Wash gently and thoroughly the contaminated skin with running water and non-abrasive soap. Seek medical attention.
<b>Inhalation</b>	Evacuate the victim to a safe area as soon as possible. If the victim is not breathing, perform artificial respiration. Allow the victim to rest in a well ventilated area. Seek medical attention.
<b>Ingestion</b>	DO NOT induce vomiting because of danger of aspirating liquid into lungs. Seek medical attention.
<b>Note to Physician</b>	Not available

<b>Section 5. Fire-fighting Measures</b>	
<b>Flammability</b>	Flammable liquid (NFPA).
<b>Flash Points</b>	CLOSED CUP: -31°C (-24°F) (NFPA)
<b>Fire Hazards in Presence of Various Substances</b>	Flammable in presence of open flames, sparks, and heat. Vapours are heavier than air and may travel considerable distance to sources of ignition and flash back. This product can accumulate static charge and ignite. May accumulate in confined spaces.
<b>Products of Combustion</b>	Carbon oxides (CO, CO <sub>2</sub> ), nitrogen oxides (NO <sub>x</sub> ), sulphur oxides (SO <sub>x</sub> ), aldehydes, ketones, smoke and irritating vapours as products of incomplete combustion.
<b>Flammable Limits</b>	LOWER: 1.3% UPPER: 8% (NFPA)
<b>Auto-Ignition Temperature</b>	240°C (464°F) (NFPA)
<b>Explosion Hazards in Presence of Various Substances</b>	Do not cut, weld, heat, drill or pressurize empty container. Containers may explode in heat of fire.

<b>Fire Fighting Media and Instructions</b>	<p>NAERG96, GUIDE 128, Flammable liquids (Non-polar/Water-immiscible). CAUTION: This product has a very low flash point: Use of water spray when fighting fire may be inefficient.</p> <p>If tank, rail car or tank truck is involved in a fire, ISOLATE for 800 meters (1/2 mile) in all directions; also consider initial evacuation for 800 meters (1/2 mile) in all directions.</p> <p>SMALL FIRES: Dry chemical, CO<sub>2</sub>, water spray or regular foam. LARGE FIRES: Water spray, fog or regular foam. Do not use straight streams. Move containers from fire area if you can do it without risk. Fires Involving Tanks or Car/Trailer Loads: Fight fire from maximum distance or use unmanned hose holders or monitor nozzles.</p> <p>Cool containers with flooding quantities of water until well after fire is out. Withdraw immediately in case of rising sound from venting devices or any discoloration of tank. ALWAYS stay away from the ends of tanks. For massive fire, use unmanned hose holders or monitor nozzles; if this is impossible withdraw from area and let fire burn. Wear positive pressure self-contained breathing apparatus (SCBA). Structural firefighters' protective clothing will only provide limited protection.</p>
---	---

### Section 6. Accidental Release Measures

<b>Material Release or Spill</b>	<p>NAERG96, GUIDE 128, Flammable Liquids (Non-polar/ Water-immiscible). ELIMINATE ALL IGNITION SOURCES. Avoid contact. Stop leak if without risk. Contain spill. Absorb with inert absorbents, dry clay, or diatomaceous earth. Avoid inhaling dust of diatomaceous earth for it may contain silica in very fine particle size, making this a potential respiratory hazard. Place used absorbent in closed metal containers for later disposal or burn absorbent in a suitable combustion chamber. DO NOT FLUSH TO SEWERS, STREAMS OR OTHER BODIES OF WATER. Check with applicable jurisdiction for specific disposal requirements of spilled material and empty containers. Notify the appropriate authorities immediately.</p>
----------------------------------	--

### Section 7. Handling and Storage

<b>Handling</b>	<p>Keep away from heat. Keep away from sources of ignition. Empty containers pose a fire risk. DO NOT reuse empty containers without commercial cleaning or reconditioning. Ground/bond line and equipment during pumping or transfer to avoid accumulation of static charge. DO NOT ingest. Do not breathe gas/vapour/spray. In case of insufficient ventilation, wear suitable respiratory equipment. If ingested, seek medical advice immediately. Avoid contact with skin and eyes. Practice good personal hygiene. Wash hands after handling and before eating. Launder work clothes frequently. Discard saturated leather goods.</p>
<b>Storage</b>	<p>Store in tightly closed containers in cool, dry, isolated, well-ventilated area, and away from incompatibles. Ground all equipment containing material. Keep away from direct sunlight.</p>

### Section 8. Exposure Controls/Personal Protection

<b>Engineering Controls</b>	<p>For normal application, special ventilation is not necessary. If user's operations generate vapours or mist, use ventilation to keep exposure to airborne contaminants below the exposure limit. Make-up air should always be supplied to balance air removed by exhaust ventilation. Ensure that eyewash station and safety shower are close to work-station.</p>
<b>Personal Protection - <i>The selection of personal protective equipment varies, depending upon conditions of use.</i></b>	
<b>Eyes</b>	<p>Eye protection (i.e., safety glasses, safety goggles and/or face shield) should be determined based on conditions of use. If product is used in an application where splashing may occur, the use of safety goggles and/or a face shield should be considered.</p>
<b>Body</b>	<p>Wear appropriate clothing to prevent skin contact. As a minimum long sleeves and trousers should be worn.</p>
<b>Respiratory</b>	<p>Where concentrations in air may exceed the occupational exposure limits given in Section 2 (and those applicable to your area) and where engineering, work practices or other means of exposure reduction are not adequate, NIOSH approved respirators may be necessary to prevent overexposure by inhalation.</p>
<b>Hands</b>	<p>Wear appropriate chemically protective gloves. When handling hot product ensure gloves are heat resistant and insulated.</p>
<b>Feet</b>	<p>Wear appropriate footwear to prevent product from coming in contact with feet and skin.</p>

### Section 9. Physical and Chemical Properties

<b>Physical State and Appearance</b>	Clear liquid.	<b>Viscosity</b>	Not available (similar to gasoline)
<b>Colour</b>	Clear and colourless.	<b>Pour Point</b>	Freezing Point: <-51°C (<-60°F) for Jet B/Jet B DI; <-58°C (<-72°F) for Jet Fuel F-40.
<b>Odour</b>	Gasoline like.	<b>Softening Point</b>	Not applicable.
<b>Odour Threshold</b>	Not available	<b>Dropping Point</b>	Not applicable.
<b>Boiling Point</b>	50 to 270°C (122 to 518°F)	<b>Penetration</b>	Not applicable.
<b>Density</b>	0.75 to 0.80 kg/L @ 15°C (59°F).	<b>Oil / Water Dist. Coefficient</b>	Not available
<b>Vapour Density</b>	3.5 (Air = 1)	<b>Ionicity (in water)</b>	Not available
<b>Vapour Pressure</b>	21 kPa (158 mmHg) @ 37.8°C (100°F).	<b>Dispersion Properties</b>	Not available
<b>Volatility</b>	Volatile.	<b>Solubility</b>	Insoluble in water. Partially miscible in some alcohols. Miscible in other petroleum solvents.

Continued on Next Page

Available in French

**Section 10. Stability and Reactivity**

<b>Corrosivity</b>	Not available		
<b>Stability</b>	The product is stable under normal handling and storage conditions.	<b>Hazardous Polymerization</b>	Will not occur under normal working conditions.
<b>Incompatible Substances / Conditions to Avoid</b>	Reactive with oxidizing agents and acids.	<b>Decomposition Products</b>	May release CO <sub>x</sub> , NO <sub>x</sub> , SO <sub>x</sub> , aldehydes, ketones, smoke and irritating vapours when heated to decomposition.

**Section 11. Toxicological Information**

<b>Routes of Entry</b>	Skin contact, eye contact, inhalation and ingestion.		
<b>Acute Lethality</b>	<p><b>Based on toxicity of similar product.</b>          Acute oral toxicity (LD50): &gt;20000 mg/kg (rat).          Acute dermal toxicity (LD50): &gt;5000 mg/kg (rabbit).          Acute inhalation toxicity (LC50): &gt;5000 mg/m<sup>3</sup>/4h (rat).</p> <p><b>Benzene</b>          Acute oral toxicity (LD50): 930 mg/kg (rat).          Acute dermal toxicity (LD50): &gt;9400 mg/kg (rabbit).          Acute inhalation toxicity (LC50): 13200 ppm/4h (rat).</p> <p><b>Diethylene Glycol Monomethyl Ether</b>          Acute oral toxicity (LD50): 4140-5180 mg/kg (rat).          Acute dermal toxicity (LD50): &gt;2000 mg/kg (rabbit).          Acute inhalation toxicity (LC50): &gt;50000 mg/m<sup>3</sup>/4h (rat).</p>		
<b>Chronic or Other Toxic Effects</b>	<p><b>Dermal Route:</b> Skin contact can cause irritation.</p> <p><b>Inhalation Route:</b> Inhalation of vapours can cause irritation of the respiratory tract and CNS depression with symptoms of nausea, headaches, vomiting, dizziness, fatigue, light-headedness, reduced coordination, unconsciousness and possibly death.</p> <p><b>Oral Route:</b> Aspiration into the lungs may produce potentially fatal chemical pneumonitis (fluid in the lungs), severe lung damage, or respiratory failure.</p> <p><b>Eye Irritation/Inflammation:</b> Eye contact can cause irritation.</p> <p><b>Immunotoxicity:</b> Not available</p> <p><b>Skin Sensitization:</b> This product is not expected to be a skin sensitizer, based on the available data and the known hazards of the components.</p> <p><b>Respiratory Tract Sensitization:</b> This product is not expected to be a respiratory tract sensitizer, based on the available data and the known hazards of the components.</p> <p><b>Mutagenic:</b> Benzene is tumorigenic by RTECS criteria.</p> <p><b>Reproductive Toxicity:</b> This product is not expected to be a reproductive hazard, based on the available data and the known hazards of the components.</p> <p><b>Teratogenicity/Embryotoxicity:</b> Fetotoxicity, embryotoxicity and/or teratogenicity have been observed in rats or rabbits following oral or dermal administration, in the absence of maternal toxicity. [Diethylene Glycol Monomethyl Ether]</p> <p><b>Carcinogenicity (ACGIH):</b> ACGIH A1: confirmed human carcinogen. [Benzene]</p> <p><b>Carcinogenicity (IARC):</b> IARC Group 1: carcinogenic to Humans. [Benzene]</p> <p><b>Carcinogenicity (NTP):</b> NTP Group 1: known to be a carcinogen. [Benzene]</p> <p><b>Carcinogenicity (IRIS):</b> Not available</p> <p><b>Carcinogenicity (OSHA):</b> Benzene is an OSHA known carcinogen.</p>		
<b>Other Considerations</b>	No additional remark.		

**Section 12. Ecological Information**

<b>Environmental Fate</b>	Not available	<b>Persistence/Bioaccumulation Potential</b>	Not available
<b>BOD5 and COD</b>	Not available	<b>Products of Biodegradation</b>	Not available
<b>Additional Remarks</b>	No additional remark.		

**Section 13. Disposal Considerations**

**Waste Disposal** Preferred waste management priorities are: (1) recycle or reprocess; (2) incineration with energy recovery; (3) disposal at licensed waste disposal facility. Ensure that disposal or reprocessing is in compliance with government requirements and local disposal regulations. Consult your local or regional authorities.

**Section 14. Transport Information**

<b>TDG Classification</b>	Currently: Fuel, aviation, turbine engine, 3, UN1863, PGII As of August 15, 2002: FUEL, AVIATION, TURBINE ENGINE, 3, UN1863, PGII	<b>Special Provisions for Transport</b>	Not applicable.
---------------------------	--	---	-----------------

**Section 15. Regulatory Information**

**Other Regulations** This product is acceptable for use under the provisions of WHMIS-CPR. All components of this formulation are listed on the CEPA-DSL (Domestic Substances List).

All components of this formulation are listed on the US EPA-TSCA Inventory.

All components of this product are on the European Inventory of Existing Commercial Chemical Substances (EINECS).

This product has been classified in accordance with the hazard criteria of the Controlled Products Regulations (CPR) and the MSDS contains all of the information required by the CPR.

Please contact Product Safety for more information.

<b>DSD/DPD (Europe)</b>	Not evaluated.	<b>HCS (U.S.A.)</b>	CLASS: Contains material which may cause cancer. CLASS: Flammable liquid having a flash point lower than 37.8°C (100°F). CLASS: Toxic. CLASS: Irritating substance. CLASS: Target organ effects.																																																
<b>ADR (Europe) (Pictograms)</b>	NOT EVALUATED FOR EUROPEAN TRANSPORT NON ÉVALUÉ POUR LE TRANSPORT EUROPÉEN.	<b>DOT (U.S.A) (Pictograms)</b>																																																	
<b>HMIS (U.S.A.)</b>	<table border="1"> <tr> <td>Health Hazard</td> <td>2*</td> </tr> <tr> <td>Fire Hazard</td> <td>3</td> </tr> <tr> <td>Reactivity</td> <td>0</td> </tr> <tr> <td>Personal Protection</td> <td>H</td> </tr> </table>	Health Hazard	2*	Fire Hazard	3	Reactivity	0	Personal Protection	H	<b>NFPA (U.S.A.)</b>	<table border="1"> <tr> <td>Health</td> <td>2</td> <td>Fire Hazard</td> <td>3</td> <td>Reactivity</td> <td>0</td> <td>Rating</td> <td>0 Insignificant</td> </tr> <tr> <td></td> <td></td> <td></td> <td></td> <td></td> <td></td> <td></td> <td>1 Slight</td> </tr> <tr> <td></td> <td></td> <td></td> <td></td> <td></td> <td></td> <td></td> <td>2 Moderate</td> </tr> <tr> <td></td> <td></td> <td></td> <td></td> <td></td> <td></td> <td></td> <td>3 High</td> </tr> <tr> <td></td> <td></td> <td></td> <td></td> <td></td> <td></td> <td></td> <td>4 Extreme</td> </tr> </table> <p>Specific hazard</p>	Health	2	Fire Hazard	3	Reactivity	0	Rating	0 Insignificant								1 Slight								2 Moderate								3 High								4 Extreme
Health Hazard	2*																																																		
Fire Hazard	3																																																		
Reactivity	0																																																		
Personal Protection	H																																																		
Health	2	Fire Hazard	3	Reactivity	0	Rating	0 Insignificant																																												
							1 Slight																																												
							2 Moderate																																												
							3 High																																												
							4 Extreme																																												

**Section 16. Other Information**

**References** Available upon request.  
\* Marque de commerce de Petro-Canada - Trademark

**Glossary**

ACGIH - American Conference of Governmental Industrial Hygienists	IRIS - Integrated Risk Information System
ADR - Agreement on Dangerous goods by Road (Europe)	LD50/LC50 - Lethal Dose/Concentration kill 50%
ASTM - American Society for Testing and Materials (	LDLo/LCLo - Lowest Published Lethal Dose/Concentration
BOD5 - Biological Oxygen Demand in 5 days	NAERG'96 - North American Emergency Response Guide Book (1996)
CAN/CGA B149.2 Propane Installation Code	NFPA - National Fire Prevention Association
CAS - Chemical Abstract Services	NIOSH - National Institute for Occupational Safety & Health
CEPA - Canadian Environmental Protection Act	NPRI - National Pollutant Release Inventory
CERCLA - Comprehensive Environmental Response, Compensation and Liability Act	NSNR - New Substances Notification Regulations (Canada)
CFR - Code of Federal Regulations	NTP - National Toxicology Program
CHIP - Chemicals Hazard Information and Packaging Approved Supply List	OSHA - Occupational Safety & Health Administration
COD5 - Chemical Oxygen Demand in 5 days	PEL - Permissible Exposure Limit
CPR - Controlled Products Regulations	RCRA - Resource Conservation and Recovery Act
DOT - Department of Transport	SARA - Superfund Amendments and Reorganization Act
DSCL - Dangerous Substances Classification and Labeling (Europe)	SD - Single Dose
DSD/DPD - Dangerous Substances or Dangerous Preparations Directives (Europe)	STEL - Short Term Exposure Limit (15 minutes)
DSL - Domestic Substance List	TDG - Transportation Dangerous Goods (Canada)
EEC/EU - European Economic Community/European Union	TDLo/TCLo - Lowest Published Toxic Dose/Concentration
EINECS - European Inventory of Existing Commercial Chemical Substances	TLm - Median Tolerance Limit
EPCRA - Emergency Planning and Community Right to Know Act	TLV-TWA - Threshold Limit Value-Time Weighted Average
FDA - Food and Drug Administration	TSCA - Toxic Substances Control Act
FIFRA - Federal Insecticide, Fungicide and Rodenticide Act	USEPA - United States Environmental Protection Agency
HCS - Hazardous Communication System	USP - United States Pharmacopoeia
HMIS - Hazardous Material Information System	WHMIS - Workplace Hazardous Material Information System
IARC - International Agency for Research on Cancer	

**For Copy of MSDS****Prepared by Product Safety - TAR on 12/3/2001.**

Western Canada, telephone: 403-296-4158; fax: 403-296-6551  
Ontario & Central Canada, telephone: 1-800-668-0220; fax: 1-800-837-1228  
Quebec & Eastern Canada, telephone: 514-640-8308; fax: 514-640-8385

Data entry by Product Safety - JDW.

For Product Safety Information: (905) 804-4752

*To the best of our knowledge, the information contained herein is accurate. However, neither the above named supplier nor any of its subsidiaries assumes any liability whatsoever for the accuracy or completeness of the information contained herein. Final determination of suitability of any material is the sole responsibility of the user. All materials may present unknown hazards and should be used with caution. Although certain hazards are described herein, we cannot guarantee that these are the only hazards that exist.*

**MATERIAL SAFETY DATA SHEET**

---

Date Prepared: November 14, 2003  
Supersedes: May 31, 2000  
MSDS Number: 08509

---

**1. PRODUCT INFORMATION**

Product Identifier: MARVELUBE WR2 GREASE

Application and Use:  
Lubricating grease

Product Description:

A grease, a mixture of lubricating oil, soap and additives.

---

**REGULATORY CLASSIFICATION**

WHMIS:  
Not a controlled product

CEPA: CANADIAN ENVIRONMENTAL PROTECTION ACT  
All components of this product are either on the Domestic  
Substances List (DSL) or are exempt.

TDG INFORMATION (RAIL/ROAD):  
Not Regulated in Canada.

Please be aware that other regulations may apply.

---

**TELEPHONE NUMBERS**

Emergency 24 hr. (519) 339-2145  
Technical Info. (800) 268-3183

**MANUFACTURER/SUPPLIER:**

IMPERIAL OIL  
Products Division  
111 St Clair Avenue West  
Toronto, Ontario  
M5W 1K3  
(416) 968-4441

---

**2. REGULATED COMPONENTS**

The following components are defined in accordance with sub-paragraph 13(a) (i) to (iv) or paragraph 14(a) of the Hazardous Products Act:

NAME	%	CAS #
Not applicable		

### 3. TYPICAL PHYSICAL & CHEMICAL PROPERTIES

Physical State: Liquid  
 Specific gravity: not available  
 Viscosity: >20.00 cSt at 40 deg C  
 Vapour Density: >5  
 Boiling Point: not available  
 Evaporation rate: <1 (1= n-butylacetate)  
 Solubility in water: negligible  
 Freezing/Pour Point: 182 deg C DROP  
 Odour Threshold: not available  
 Vapour Pressure: <1 kPa at 38 deg C  
 Density: 0.91 g/cc at 15 deg C  
 Appearance/odour: Black paste, petroleum odour.

### 4. HEALTH HAZARD INFORMATION

#### NATURE OF HAZARD

##### INHALATION:

Negligible hazard at normal temperatures (up to 38 deg C).  
 Elevated temperatures or mechanical action may form vapours, mists or fumes which may be irritating to the eyes, nose, throat and lungs.  
 Avoid breathing vapours or mists.

##### EYE CONTACT:

Slightly irritating, but will not injure eye tissue.

##### SKIN CONTACT:

Low toxicity.  
 Frequent or prolonged contact may irritate the skin.  
 High pressure greasing equipment is capable of injecting grease under the skin which may have severe health consequences.

##### INGESTION:

Low toxicity.

##### ACUTE TOXICITY DATA:

Based on animal testing data from similar materials and products, the acute toxicity of this product is expected to be:

Oral : LD50 > 5000 mg/kg (Rat)  
Dermal : LD50 > 3160 mg/kg (Rabbit)  
Inhalation : LC50 > 5000 mg/m3 (Rat)

**OCCUPATIONAL EXPOSURE LIMIT:**

**ACGIH recommends:**

For oil mists, 5 mg/m3.

Local regulated limits may vary.

---

## 5. FIRST AID MEASURES

**INHALATION:**

In case of adverse exposure to vapours, mists and/or fumes formed at elevated temperature, or by mechanical action, immediately remove the affected victim from exposure. Administer artificial respiration if breathing has stopped. Keep at rest. Call for prompt medical attention.

**EYE CONTACT:**

Flush eyes with large amounts of water until irritation subsides. If irritation persists, get medical attention.

**SKIN CONTACT:**

Flush with large amounts of water. Use soap if available. Remove severely contaminated clothing (including shoes) and launder before reuse. If irritation persists, seek medical attention. Consult a physician immediately if the material is injected under the skin from the misuse of high pressure greasing equipment.

**INGESTION:**

If swallowed, DO NOT induce vomiting. Keep at rest. Get prompt medical attention.

---

## 6. PREVENTIVE AND CORRECTIVE MEASURES

**PERSONAL PROTECTION:**

The selection of personal protective equipment varies, depending upon conditions of use. In open systems where contact is likely, wear safety goggles, chemical-resistant overalls, and chemically impervious gloves. Where only incidental contact is likely, wear safety glasses with side shields. No other special precautions are necessary provided skin/eye

contact is avoided.

Where concentrations in air may exceed the occupational exposure limits given in Section 4 and where engineering, work practices or other means of exposure reduction are not adequate, approved respirators may be necessary to prevent overexposure by inhalation.

**ENGINEERING CONTROLS:**

The use of local exhaust ventilation is recommended to control emissions near the source. Laboratory samples should be handled in a fumehood. Provide mechanical ventilation of confined spaces.

**HANDLING, STORAGE AND SHIPPING:**

Keep containers closed. Handle and open containers with care. Store in a cool, well ventilated place away from incompatible materials. In keeping with good personal hygiene practices, wash hands thoroughly after handling the material. Empty containers may contain product residue. Do not pressurize cut, heat, or weld empty containers. Do not reuse empty containers without commercial cleaning or reconditioning.

**LAND SPILL:**

Eliminate source of ignition. Keep public away. Prevent additional discharge of material, if possible to do so without hazard. Prevent spills from entering sewers, watercourses or low areas. Contain spilled liquid with sand or earth. Allow material to solidify and scrape up. Place material in suitable containers for recycle or disposal. Consult an expert on disposal of recovered material. Ensure disposal in compliance with government requirements and ensure conformity to local disposal regulations. Notify the appropriate authorities immediately. Take all additional action necessary to prevent and remedy the adverse effects of the spill.

**WATER SPILL:**

Remove from surface by skimming or with suitable absorbents. If allowed by local authorities and environmental agencies, sinking and/or suitable dispersants may be used in unconfined waters. Consult an expert on disposal of recovered material. Ensure disposal in compliance with government requirements and ensure conformity to local disposal regulations. Notify the appropriate authorities immediately. Take all additional action necessary to prevent and remedy the adverse effects of the spill.

**7. FIRE AND EXPLOSION HAZARD**

Flashpoint and method: 204 deg C COC ASTM D92

Autoignition: 227 deg C Flammable Limits: LEL: NA UEL: NA

**GENERAL HAZARDS:**

Low Hazard; liquids may burn upon heating to temperatures at or above the flash point.  
Toxic gases will form upon combustion.

**FIRE FIGHTING:**

Use water spray to cool fire exposed surfaces and to protect personnel.  
Shut off fuel to fire.  
Use foam, dry chemical or water spray to extinguish fire.  
Respiratory and eye protection required for fire fighting personnel.  
A self-contained breathing apparatus (SCBA) should be used for all indoor fires and any significant outdoor fires. For small outdoor fires, which may easily be extinguished with a portable fire extinguisher, use of an SCBA may not be required.

**HAZARDOUS COMBUSTION PRODUCTS:**

Smoke, carbon monoxide, carbon dioxide and traces of oxides of sulphur

---

**8. REACTIVITY DATA**

**STABILITY:**

This product is stable. Hazardous polymerization will not occur.

**INCOMPATIBLE MATERIALS AND CONDITIONS TO AVOID:**

Strong oxidizing agents

**HAZARDOUS DECOMPOSITION:**

none

---

**9. NOTES**

All components of this product are listed on the U.S. TSCA inventory.

.

**REVISION SUMMARY:**

Since 31 May 2000, this MSDS has been revised in Section(s):  
3, 7

---

**10. PREPARATION**

Date Prepared: November 14, 2003  
Prepared by: Lubricants & Specialties

IMPERIAL OIL  
Products Division  
111 St Clair Avenue West  
Toronto, Ontario  
M5W 1K3  
(800) 268-3183

---

CAUTION: " The information contained herein relates only to this product or material and may not be valid when used in combination with any other product or material or in any process. If the product is not to be used for a purpose or under conditions which are normal or reasonably foreseeable, this information cannot be relied upon as complete or applicable. For greater certainty, uses other than those described in Section 1 must be reviewed with the supplier. The information contained herein is based on the information available at the indicated date of preparation. This MSDS is for the use of Imperial Oil customers and their employees and agents only. Any further distribution of this MSDS by Imperial Oil customers is prohibited without the written consent of Imperial Oil."



## MATERIAL SAFETY DATA SHEET

Date Prepared: November 06, 2002  
 Supersedes: November 01, 2002  
 MSDS Number: 00826

### 1. PRODUCT INFORMATION

Product Identifier: MIDDLE DISTILLATE

- ESSO MARINE GAS OIL (DYED OR CLEAR)
- ESSO RAILROAD DIESEL (DYED OR CLEAR)
- HEATING OIL (DYED OR CLEAR)
- DIESEL (DYED OR CLEAR)
- DIESEL QUALITY FURNACE FUEL (DYED OR CLEAR)
- DIESEL QUALITY HEATING OIL (DYED OR CLEAR)
- ESSO DIESEL (DYED OR CLEAR)
- ESSO DIESEL QUALITY COMMERCIAL FUEL (DYED OR CLEAR)
- ESSO DIESEL QUALITY FURNACE FUEL
- ESSO DIESEL QUALITY HEATING OIL
- ESSO FURNACE FUEL (DYED OR CLEAR)
- ESSO HEATING OIL (DYED OR CLEAR)
- ESSO MARINE DIESEL FUEL (DYED OR CLEAR)
- ESSO RAILROAD DIESEL FUEL #3 (DYED OR CLEAR)
- ESSO TOBACCO CURING OIL
- FUEL OIL 75
- FUEL OIL 76
- DIESEL MARINE (DYED OR CLEAR)
- DIESEL MARINE GAS OIL (DYED OR CLEAR)
- FURNACE (DYED OR CLEAR)
- DIESEL MARINE - POUR DEPRESSED (DYED OR CLEAR)
- NO.2 FUEL OIL
- NAVAL FUEL OIL 3-GP-11M (DYED)
- ESSO DIESEL FUEL LS
- DIESEL LOW SULFUR (DYED OR CLEAR)
- NO.2 FUEL OIL FOR EXPORT
- DIESEL FOR EXPORT (DYED OR CLEAR)
- FURNACE TOBACCO CURING OIL
- DIESEL NAVAL 3GP-11 (DYED OR CLEAR)
- DIESEL NAVAL 3GP-15 (DYED OR CLEAR)
- DIESEL LOW SULFUR RAIL (DYED OR CLEAR)
- DIESEL LOW SULFUR DYED EP
- DIESEL RAIL (DYED OR CLEAR)
- DIESEL RAIL #3 (DYED OR CLEAR)
- DIESEL RAIL #3 (HD) (DYED OR CLEAR)
- DIESEL LOW SULFUR (032) (DYED OR CLEAR)

FURNACE URBAN (DYED OR CLEAR)  
 DIESEL (032) (DYED OR CLEAR)  
 DIESEL LOW SULFUR (EXP DYED)  
 FURNACE FUEL (032) DYED  
 DIESEL LOW SULFUR (EXPORT)  
 MARINE GAS OIL  
 MDO - MARINE DIESEL OIL 3 CST (CLEAR)

Application and Use:  
 Multi-purpose fuel

Product Description:

A complex mixture of aliphatic, olefinic, naphthenic and aromatic hydrocarbons.

#### REGULATORY CLASSIFICATION

##### WHMIS:

Class B, Division 3: Combustible Liquids.  
 Class D, Division 2, Subdivision B: Toxic Material

##### CEPA: CANADIAN ENVIRONMENTAL PROTECTION ACT

All components of this product are either on the Domestic Substances List (DSL) or are exempt.

##### TDG INFORMATION (RAIL/ROAD):

Shipping Name: FUEL OIL  
 Class: 3  
 Packing Group: III  
 PIN Number: UN1202  
 Marine Pollutant:N

Please be aware that other regulations may apply.

#### TELEPHONE NUMBERS

Emergency 24 hr. (519) 339-2145  
 Technical Info. (800) 268-3183

#### MANUFACTURER/SUPPLIER:

IMPERIAL OIL  
 Products Division  
 111 St Clair Avenue West  
 Toronto, Ontario  
 M5W 1K3  
 (416) 968-4441

## 2. REGULATED COMPONENTS

The following components are defined in accordance with sub-paragraph 13(a) (i) to (iv) or paragraph 14(a) of the Hazardous Products Act:

NAME	%	CAS #
------	---	-------

Fuel Oil No.2

&gt;99.9 V/V 68476-30-2

---

### 3. TYPICAL PHYSICAL & CHEMICAL PROPERTIES

Physical State: Liquid  
Specific gravity: 0.820 to 0.900 at 15.5 deg C  
Viscosity: 1.30 cSt at 40 deg C  
to 11.00 cSt at 40 deg C  
Vapour Density: 4  
Boiling Point: 150 to 370 deg C  
Evaporation rate: <1 (1= n-butylacetate)  
Solubility in water: negligible  
Freezing/Pour Point: -4 deg C -39 (RANGE)  
Odour Threshold: not available  
Vapour Pressure: 4 kPa at 38 deg C  
Appearance/odour: White or pale yellow liquid, petroleum odour

---

### 4. HEALTH HAZARD INFORMATION

#### NATURE OF HAZARD

##### INHALATION:

Negligible hazard at normal temperatures (up to 38 deg C).  
High vapour concentrations are irritating to the eyes, nose, throat and lungs; may cause headaches and dizziness; may be anesthetic and may cause other central nervous system effects.  
Avoid breathing vapours or mists.

##### EYE CONTACT:

Slightly irritating, but will not injure eye tissue.

##### SKIN CONTACT:

Low toxicity.  
Irritating.

##### INGESTION:

Low toxicity.  
Small amounts of this liquid drawn into the lungs from swallowing or vomiting may cause severe health effects (e.g. bronchopneumonia or pulmonary edema).

##### CHRONIC:

Lifetime skin painting tests indicate that materials of similar composition have produced skin cancer in experimental animals. The relationship of these results to humans has not been fully established.

**ACUTE TOXICITY DATA:**

Based on animal testing data from similar materials and products, the acute toxicity of this product is expected to be:

Oral : LD50 > 5000 mg/kg (Rat)  
Dermal : LD50 > 2000 mg/kg (Rabbit)  
Inhalation : LC50 > 2500 mg/m<sup>3</sup> (Rat)

**OCCUPATIONAL EXPOSURE LIMIT:**

Manufacturer Recommends:  
100 ppm based on composition.

Local regulated limits may vary.

---

## 5. FIRST AID MEASURES

**INHALATION:**

In emergency situations use proper respiratory protection to immediately remove the affected victim from exposure. Administer artificial respiration if breathing has stopped. Keep at rest. Call for prompt medical attention.

**EYE CONTACT:**

Flush eyes with large amounts of water until irritation subsides. If irritation persists, get medical attention.

**SKIN CONTACT:**

Immediately flush with large amounts of water. Use soap if available. Remove contaminated clothing, including shoes, after flushing has begun. If irritation persists, seek medical attention.

**INGESTION:**

DO NOT induce vomiting since it is important that no amount of the material should enter the lungs (aspiration). Keep at rest. Get prompt medical attention.

---

## 6. PREVENTIVE AND CORRECTIVE MEASURES

**PERSONAL PROTECTION:**

The selection of personal protective equipment varies, depending upon conditions of use.

In open systems where contact is likely, wear safety goggles, chemical-resistant overalls, and chemically impervious gloves.

Where only incidental contact is likely, wear safety goggles, long sleeves, and chemical-resistant gloves.

Where concentrations in air may exceed the occupational exposure limits given in Section 4 and where engineering, work practices or other means of exposure reduction are not adequate, approved respirators may be necessary to prevent overexposure by inhalation.

**ENGINEERING CONTROLS:**

The use of local exhaust ventilation is recommended to control emissions near the source. Laboratory samples should be handled in a fumehood. Provide mechanical ventilation of confined spaces.

**HANDLING, STORAGE AND SHIPPING:**

Keep containers closed. Handle and open containers with care. Store in a cool, well ventilated place away from incompatible materials. In keeping with good personal hygiene practices, wash hands thoroughly after handling the material. Do not handle or store near an open flame, sources of heat, or sources of ignition. Material will accumulate static charges which may cause a spark. Static charge build-up could become an ignition source. Use proper relaxation and grounding procedures. Empty containers may contain product residue. Do not pressurize cut, heat, or weld empty containers. Do not reuse empty containers without commercial cleaning or reconditioning.

**LAND SPILL:**

Eliminate source of ignition. Keep public away. Prevent additional discharge of material, if possible to do so without hazard. Prevent spills from entering sewers, watercourses or low areas. Contain spilled liquid with sand or earth. Do not use combustible materials such as sawdust. Recover by pumping (use an explosion proof motor or hand pump), or by using a suitable absorbent. Consult an expert on disposal of recovered material. Ensure disposal in compliance with government requirements and ensure conformity to local disposal regulations. Notify the appropriate authorities immediately. Take all additional action necessary to prevent and remedy the adverse effects of the spill.

**WATER SPILL:**

Remove from surface by skimming or with suitable absorbents. If allowed by local authorities and environmental agencies, sinking and/or suitable dispersants may be used in unconfined waters. Consult an expert on disposal of recovered material. Ensure disposal in compliance with government requirements and ensure conformity to local disposal regulations. Notify the appropriate authorities immediately. Take all additional action necessary to prevent and remedy the adverse effects of the spill.

---

**7. FIRE AND EXPLOSION HAZARD**

Flashpoint and method: >40 deg C PMCT ASTM D93

Autoignition: NA Flammable Limits: LEL: 0.7% UEL: 6.5%

**GENERAL HAZARDS:**

Combustible Liquid; may form combustible mixtures at or above the flash point.

Toxic gases will form upon combustion.

Static Discharge; material may accumulate static charges which may cause a fire.

**FIRE FIGHTING:**

Use water spray to cool fire exposed surfaces and to protect personnel. Shut off fuel to fire.

Use foam, dry chemical or water spray to extinguish fire.

Respiratory and eye protection required for fire fighting personnel.

Avoid spraying water directly into storage containers due to danger of boilover.

A self-contained breathing apparatus (SCBA) should be used for all indoor fires and any significant outdoor fires. For small outdoor fires, which may easily be extinguished with a portable fire extinguisher, use of an SCBA may not be required.

**HAZARDOUS COMBUSTION PRODUCTS:**

Smoke, carbon monoxide, carbon dioxide and traces of oxides of sulphur

---

## 8. REACTIVITY DATA

**STABILITY:**

This product is stable. Hazardous polymerization will not occur.

**INCOMPATIBLE MATERIALS AND CONDITIONS TO AVOID:**

Strong oxidizing agents

**HAZARDOUS DECOMPOSITION:**

none

---

## 9. NOTES

All components of this product are listed on the U.S. TSCA inventory.

REVISED.

## 10. PREPARATION

Date Prepared: November 06, 2002  
Prepared by: Lubricants & Specialties  
IMPERIAL OIL  
Products Division  
111 St Clair Avenue West  
Toronto, Ontario  
M5W 1K3  
(800) 268-3183

---

CAUTION: " The information contained herein relates only to this product or material and may not be valid when used in combination with any other product or material or in any process. If the product is not to be used for a purpose or under conditions which are normal or reasonably foreseeable, this information cannot be relied upon as complete or applicable. For greater certainty, uses other than those described in Section 1 must be reviewed with the supplier. The information contained herein is based on the information available at the indicated date of preparation. This MSDS is for the use of Imperial Oil customers and their employees and agents only. Any further distribution of this MSDS by Imperial Oil customers is prohibited without the written consent of Imperial Oil."



WHMIS (Pictograms)	WHMIS (Classification)	Protective Clothing	TDG (pictograms)
	<b>Not controlled</b>		

<b>Section 1. Chemical Product and Company Identification</b>			
<b>Product Name</b>	<b>PETRO-CANADA SUPREME 5W-30, 10W-30, 10W-40, 20W-50 MOTOR OIL</b>	<b>Code</b>	410-344, MOSP53 410-341, MOSP13 410-342, MOSP14 410-343, MOSP25
<b>Synonym</b>	Not available.	<b>Validated on</b>	<b>8/31/2004.</b>
<b>Manufacturer</b>	PETRO-CANADA P.O. Box 2844 Calgary, Alberta T2P 3E3	<b>In case of Emergency</b>	Petro-Canada: 403-296-3000 Canutec Transportation: 613-996-6666 Poison Control Centre: Consult local telephone directory for emergency number(s).
<b>Material Uses</b>	Supreme is designed for the lubrication of all gasoline, propane and CNG engines where the manufacturer recommends the use of API SM quality oils. SAE 5W-30 and 10W-30 grades also meet the requirements of ILSAC GF-4.		

<b>Section 2. Composition and Information on Ingredients</b>					
			<i>Exposure Limits (ACGIH)</i>		
Name	CAS #	% (W/W)	TLV-TWA(8 h)	STEL	CEILING
Mixture of severely hydrotreated and hydrocracked base oil (petroleum) and other proprietary, non-hazardous additives.	Mixture	100	5 mg/m <sup>3</sup> (oil mist)	10 mg/m <sup>3</sup> (oil mist)	Not established
<b>Manufacturer Recommendation</b>	Not applicable				
<b>Other Exposure Limits</b>	Consult local, state, provincial or territory authorities for acceptable exposure limits.				

<b>Section 3. Hazards Identification.</b>	
<b>Potential Health Effects</b>	Prolonged or repeated contact may cause skin irritation, defatting, drying and dermatitis. Not expected to cause more than slight skin or eye irritation. With its relatively low vapour pressure, this product is not expected to be inhaled in any appreciable quantity at ambient conditions. If heated to high temperatures or subjected to mechanical actions which produce vapours or mists, inhalation may cause respiratory tract irritation. Ingestion may produce a laxative effect. For more information refer to Section 11 of this MSDS.

<b>Section 4. First Aid Measures</b>	
<b>Eye Contact</b>	IMMEDIATELY flush eyes with running water for at least 15 minutes, keeping eyelids open. Seek medical attention.
<b>Skin Contact</b>	Remove contaminated clothing - launder before reuse. Wash gently and thoroughly the contaminated skin with running water and non-abrasive soap. Seek medical attention.
<b>Inhalation</b>	Evacuate the victim to a safe area as soon as possible. If the victim is not breathing, perform artificial respiration. Allow the victim to rest in a well ventilated area. Seek medical attention.
<b>Ingestion</b>	DO NOT induce vomiting because of danger of aspirating liquid into lungs. Seek medical attention.
<b>Note to Physician</b>	Not available

<b>Section 5. Fire-fighting Measures</b>			
<b>Flammability</b>	May be combustible at high temperature.	<b>Flammable Limits</b>	Not available.
<b>Flash Points</b>	OPEN CUP: 223°C (433.4°F) (Cleveland)	<b>Auto-Ignition Temperature</b>	Not available
<b>Fire Hazards in Presence of Various Substances</b>	Low fire hazard. This material must be heated before ignition will occur.	<b>Explosion Hazards in Presence of Various Substances</b>	Do not cut, weld, heat, drill or pressurize empty container. Containers may explode in heat of fire.

<b>Products of Combustion</b>	Carbon oxides (CO, CO <sub>2</sub> ), nitrogen oxides (NO <sub>x</sub> ), sulphur oxides (SO <sub>x</sub> ), calcium oxides (CaO <sub>x</sub> ), phosphorus compounds (PO <sub>x</sub> ), zinc oxides, boron oxides and molybdenum, smoke and irritating vapours as products of incomplete combustion.
<b>Fire Fighting Media and Instructions</b>	NAERG96, GUIDE 171, Substances (low to moderate hazard). If tank, rail car or tank truck is involved in a fire, ISOLATE for 800 meters (0.5 mile) in all directions; also, consider initial evacuation for 800 meters (0.5 mile) in all directions. Shut off fuel to fire if it is possible to do so without hazard. If this is impossible, withdraw from area and let fire burn out under controlled conditions. Withdraw immediately in case of rising sound from venting safety device or any discolouration of tank due to fire. Cool containing vessels with water spray in order to prevent pressure build-up, autoignition or explosion. <b>SMALL FIRE:</b> use DRY chemicals, foam, water spray or CO <sub>2</sub> . <b>LARGE FIRE:</b> use water spray, fog or foam. For small outdoor fires, portable fire extinguishers may be used, and self contained breathing apparatus (SCBA) may not be required. For all indoor fires and any significant outdoor fires, SCBA is required. Respiratory and eye protection are required for fire fighting personnel.

**Section 6. Accidental Release Measures**

<b>Material Release or Spill</b>	Consult current National Emergency Response Guide Book (NAERG) for appropriate spill measures if necessary. Extinguish all ignition sources. Stop leak if safe to do so. Dike spilled material. Use appropriate inert absorbent material to absorb spilled product. Collect used absorbent for later disposal. Avoid contact with spilled material. Avoid contaminating sewers, streams, rivers and other water courses with spilled material. Notify appropriate authorities immediately.
----------------------------------	--

**Section 7. Handling and Storage**

<b>Handling</b>	Avoid contact with any sources of ignition, flames, heat, and sparks. Avoid skin contact. Avoid eye contact. Avoid inhalation of product vapours or mists. Empty containers may contain product residue. Do not pressurize, cut, heat, or weld empty containers. Do not reuse containers without commercial cleaning and/or reconditioning. Personnel who handle this material should practice good personal hygiene during and after handling to help prevent accidental ingestion of this product. Properly dispose of contaminated leather articles including shoes that cannot be decontaminated.
<b>Storage</b>	Store away from incompatible and reactive materials (See section 5 and 10). Keep container tightly closed. Store in dry, cool, well-ventilated area.

**Section 8. Exposure Controls/Personal Protection**

<b>Engineering Controls</b>	For normal application, special ventilation is not necessary. If user's operations generate vapours or mist, use ventilation to keep exposure to airborne contaminants below the exposure limit. Make-up air should always be supplied to balance air removed by exhaust ventilation. Ensure that eyewash station and safety shower are close to work-station.
<b>Personal Protection - The selection of personal protective equipment varies, depending upon conditions of use.</b>	
<b>Eyes</b>	Eye protection (i.e., safety glasses, safety goggles and/or face shield) should be determined based on conditions of use. If product is used in an application where splashing may occur, the use of safety goggles and/or a face shield should be considered.
<b>Body</b>	Wear appropriate clothing to prevent skin contact. As a minimum long sleeves and trousers should be worn.
<b>Respiratory</b>	Where concentrations in air may exceed the occupational exposure limits given in Section 2 (and those applicable to your area) and where engineering, work practices or other means of exposure reduction are not adequate, NIOSH approved respirators may be necessary to prevent overexposure by inhalation.
<b>Hands</b>	Wear appropriate chemically protective gloves. When handling hot product ensure gloves are heat resistant and insulated.
<b>Feet</b>	Wear appropriate footwear to prevent product from coming in contact with feet and skin.

**Section 9. Physical and Chemical Properties**

<b>Physical State and Appearance</b>	Viscous liquid.	<b>Viscosity</b>	5W-30: 62.3 cSt @ 40°C (104°F), 10.6 cSt @ 100°C (212°F). VI=160 10W-30: 67.4 cSt @ 40°C (104°F), 10.5 cSt @ 100°C (212°F). VI=143 10W-40: 97.2 cSt @ 40°C (104°F), 14.1 cSt @ 100°C (212°F). VI=143 20W-50: 170 cSt @ 40°C (104°F), 19.0 cSt @ 100°C (212°F). VI=127
<b>Colour</b>	Light amber.	<b>Pour Point</b>	5W-30: -36°C (-33°F) 10W-30: -36°C (-33°F) 10W-40: -30°C (-22°F) 20W-50: -24°C (-11°F)
<b>Odour</b>	Mild petroleum oil like.	<b>Softening Point</b>	Not applicable.
<b>Odour Threshold</b>	Not available.	<b>Dropping Point</b>	Not applicable.
<b>Boiling Point</b>	Not available.	<b>Penetration</b>	Not applicable.

<b>Density</b>	0.8566 - 0.8775 kg/L @ 15°C (59°F).	<b>Oil / Water Dist. Coefficient</b>	Not available.
<b>Vapour Density</b>	Not available.	<b>Ionicity (in water)</b>	Not available
<b>Vapour Pressure</b>	Negligible at ambient temperature and pressure.	<b>Dispersion Properties</b>	Not available
<b>Volatility</b>	Non-volatile	<b>Solubility</b>	Insoluble in water.

### Section 10. Stability and Reactivity

<b>Corrosivity</b>	Copper corrosion, 3h, 121°C (ASTM D0130): 1a		
<b>Stability</b>	The product is stable under normal handling and storage conditions.	<b>Hazardous Polymerization</b>	Will not occur under normal working conditions.
<b>Incompatible Substances / Conditions to Avoid</b>	Reactive with oxidizing agents and acids.	<b>Decomposition Products</b>	May release CO <sub>x</sub> , H <sub>2</sub> S, methacrylate monomers, alkyl mercaptans, smoke and irritating vapours when heated to decomposition.

### Section 11. Toxicological Information

<b>Routes of Entry</b>	Skin contact, eye contact, inhalation, and ingestion.		
<b>Acute Lethality</b>	Acute toxicity information is not available for the product as a whole, therefore, data for some of the ingredients is provided below: Acute oral toxicity (LD50): >5000 mg/kg (rat). Acute dermal toxicity (LD50): >2000 mg/kg (rabbit). Acute inhalation toxicity (LC50): >2500 mg/m <sup>3</sup> /4h (rat).		
<b>Chronic or Other Toxic Effects</b>			
Dermal Route:	Prolonged or repeated contact may defat and dry skin, and cause dermatitis. Short-term exposure is expected to cause only slight irritation, if any.		
Inhalation Route:	With its relatively low vapour pressure, this product is not expected to be inhaled in any appreciable quantity at ambient conditions. If heated to high temperatures or subjected to mechanical actions which produce vapours or mists, inhalation may cause respiratory tract irritation.		
Oral Route:	Ingestion of this product may lead to aspiration of the liquid, especially if vomiting occurs. This may result in chemical pneumonitis (inflammation of the lungs) and/or pulmonary edema (an accumulation of fluid in the lungs). May produce a laxative effect.		
Eye Irritation/Inflammation:	Short-term exposure is expected to cause only slight irritation, if any.		
Immunotoxicity:	Not available.		
Skin Sensitization:	Contact with this product is not expected to cause skin sensitization, based upon the available data and the known hazards of the components.		
Respiratory Tract Sensitization:	Contact with this product is not expected to cause respiratory tract sensitization, based upon the available data and the known hazards of the components.		
Mutagenic:	This product is not known to contain any components at >= 0.1% that have been shown to cause mutagenicity. Therefore, based upon the available data and the known hazards of the components, this product is not expected to be a mutagen.		
Reproductive Toxicity:	This product is not known to contain any components at >= 0.1% that have been shown to cause reproductive toxicity. Therefore, based upon the available data and the known hazards of the components, this product is not expected to be a reproductive toxin.		
Teratogenicity/Embryotoxicity:	This product is not known to contain any components at >= 0.1% that have been shown to cause teratogenicity and/or embryotoxicity. Therefore, based upon the available data and the known hazards of the components, this product is not expected to be a teratogen/embryotoxin.		
Carcinogenicity (ACGIH):	This product is not known to contain any chemicals at reportable quantities that are listed as Group A1 or A2 carcinogens by ACGIH.		
Carcinogenicity (IARC):	This product is not known to contain any chemicals at reportable quantities that are listed as Group 1, 2A, or 2B carcinogens by IARC.		
Carcinogenicity (NTP):	This product is not known to contain any chemicals at reportable quantities that are listed as carcinogens by NTP.		
Carcinogenicity (IRIS):	This product is not known to contain any chemicals at reportable quantities that are listed as carcinogens by IRIS.		
Carcinogenicity (OSHA):	This product is not known to contain any chemicals at reportable quantities that are listed as carcinogens by OSHA.		
<b>Other Considerations</b>	No additional remark.		

**Section 12. Ecological Information**

<b>Environmental Fate</b>	Not available	<b>Persistence/Bioaccumulation Potential</b>	Not available
<b>BOD5 and COD</b>	Not available.	<b>Products of Biodegradation</b>	Not available.
<b>Additional Remarks</b>	No additional remark.		

**Section 13. Disposal Considerations**

<b>Waste Disposal</b>	Spent/ used/ waste product may meet the requirements of a hazardous waste. Consult your local or regional authorities. Ensure that waste management processes are in compliance with government requirements and local disposal regulations.
-----------------------	--

**Section 14. Transport Information**

<b>TDG Classification</b>	Not a hazardous material for transport according to the TDG Regulations. (Canada)	<b>Special Provisions for Transport</b>	Not applicable.
---------------------------	---	---	-----------------

**Section 15. Regulatory Information**

<b>Other Regulations</b>	<p>This product is acceptable for use under the provisions of WHMIS-CPR. All components of this formulation are listed on the CEPA-DSL (Domestic Substances List).</p> <p>All components of this formulation are listed on the US EPA-TSCA Inventory.</p> <p>All components of this product are on the European Inventory of Existing Commercial Chemical Substances (EINECS).</p> <p>This product has been classified in accordance with the hazard criteria of the Controlled Products Regulations (CPR) and the MSDS contains all of the information required by the CPR.</p> <p>Please contact Product Safety for more information.</p>		
--------------------------	---	--	--

<b>DSD/DPD (Europe)</b>	Not evaluated.	<b>HCS (U.S.A.)</b>	Does not meet the definitions of a health or physical hazard according to the OSHA - Hazard Communication Standard. (United States)
-------------------------	----------------	---------------------	---

<b>ADR (Europe) (Pictograms)</b>	NOT EVALUATED FOR EUROPEAN TRANSPORT NON ÉVALUÉ POUR LE TRANSPORT EUROPÉEN.	<b>DOT (U.S.A) (Pictograms)</b>	
----------------------------------	--	---------------------------------	--

<b>HMIS (U.S.A.)</b>	<table border="1"> <tr><td>Health Hazard</td><td>1</td></tr> <tr><td>Fire Hazard</td><td>1</td></tr> <tr><td>Reactivity</td><td>0</td></tr> <tr><td>Personal Protection</td><td>B</td></tr> </table>	Health Hazard	1	Fire Hazard	1	Reactivity	0	Personal Protection	B	<b>NFPA (U.S.A.)</b>	<table border="1"> <tr><td>Health</td><td>1</td><td>Fire Hazard</td><td>1</td></tr> <tr><td></td><td>1</td><td>Reactivity</td><td>0</td></tr> <tr><td></td><td></td><td>Specific hazard</td><td></td></tr> </table>	Health	1	Fire Hazard	1		1	Reactivity	0			Specific hazard		<b>Rating</b>	0 Insignificant 1 Slight 2 Moderate 3 High 4 Extreme
Health Hazard	1																								
Fire Hazard	1																								
Reactivity	0																								
Personal Protection	B																								
Health	1	Fire Hazard	1																						
	1	Reactivity	0																						
		Specific hazard																							

**Section 16. Other Information**

<b>References</b>	Available upon request. * Marque de commerce de Petro-Canada - Trademark
-------------------	---

<b>Glossary</b>	<p>ACGIH - American Conference of Governmental Industrial Hygienists</p> <p>ADR - Agreement on Dangerous goods by Road (Europe)</p> <p>ASTM - American Society for Testing and Materials</p> <p>BOD5 - Biological Oxygen Demand in 5 days</p> <p>CAN/CGA B149.2 Propane Installation Code</p> <p>CAS - Chemical Abstract Services</p> <p>CEPA - Canadian Environmental Protection Act</p> <p>CERCLA - Comprehensive Environmental Response, Compensation and Liability Act</p> <p>CFR - Code of Federal Regulations</p> <p>CHIP - Chemicals Hazard Information and Packaging Approved Supply List</p> <p>COD5 - Chemical Oxygen Demand in 5 days</p> <p>CPR - Controlled Products Regulations</p> <p>DOT - Department of Transport</p> <p>DSCL - Dangerous Substances Classification and Labeling (Europe)</p> <p>DSD/DPD - Dangerous Substances or Dangerous Preparations</p> <p>IRIS - Integrated Risk Information System</p> <p>LD50/LC50 - Lethal Dose/Concentration kill 50%</p> <p>LDLo/LCLo - Lowest Published Lethal Dose/Concentration</p> <p>NAERG'96 - North American Emergency Response Guide Book (1996)</p> <p>NFPA - National Fire Prevention Association</p> <p>NIOSH - National Institute for Occupational Safety &amp; Health</p> <p>NPRI - National Pollutant Release Inventory</p> <p>NSNR - New Substances Notification Regulations (Canada)</p> <p>NTP - National Toxicology Program</p> <p>OSHA - Occupational Safety &amp; Health Administration</p> <p>PEL - Permissible Exposure Limit</p> <p>RCRA - Resource Conservation and Recovery Act</p> <p>SARA - Superfund Amendments and Reorganization Act</p> <p>SD - Single Dose</p> <p>STEL - Short Term Exposure Limit (15 minutes)</p> <p>TDG - Transportation Dangerous Goods (Canada)</p> <p>TDL0/TCLo - Lowest Published Toxic Dose/Concentration</p>
-----------------	--

Directives (Europe)  
DSL - Domestic Substance List  
EEC/EU - European Economic Community/European Union  
EINECS - European Inventory of Existing Commercial Chemical Substances  
EPCRA - Emergency Planning and Community Right to Know Act  
FDA - Food and Drug Administration  
FIFRA - Federal Insecticide, Fungicide and Rodenticide Act  
HCS - Hazard Communication Standard  
HMIS - Hazardous Material Information System  
IARC - International Agency for Research on Cancer

TLM - Median Tolerance Limit  
TLV-TWA - Threshold Limit Value-Time Weighted Average  
TSCA - Toxic Substances Control Act  
USEPA - United States Environmental Protection Agency  
USP - United States Pharmacopoeia  
WHMIS - Workplace Hazardous Material Information System

**For Copy of MSDS**

**The Canadian Controlled Products Regulations (CPR) (Under the Hazardous Products Act, part of the WHMIS legislation) only apply to WHMIS Controlled (i.e., hazardous) products. Therefore, the CPR and the 3-year update rule specified therein do not apply to WHMIS Non-Controlled products. Although this is true, customarily Petro-Canada reviews and updates Non-Controlled product MSDS if a customer requests such an update. These Non-Controlled product updates are given a lower priority than Controlled products but are handled as soon as practicable. If you would like to verify if the MSDS you have is the most current, or you require any further information, please contact:**

Internet: [www.petro-canada.ca](http://www.petro-canada.ca)

**Lubricants:**

Western Canada, telephone: 1-800-661-1199; fax: (780) 464-9564

Ontario & Central Canada, telephone: 1-800-268-5850 and (905) 822-4222; fax: 1-800-201-6285

Quebec & Eastern Canada, telephone: 1-800-576-1686; fax: 800-201-6285

**For Product Safety Information: (905) 804-4752**

Prepared by Product Safety - TLM on 8/31/2004.

Data entry by Product Safety - RS.

*To the best of our knowledge, the information contained herein is accurate. However, neither the above named supplier nor any of its subsidiaries assumes any liability whatsoever for the accuracy or completeness of the information contained herein. Final determination of suitability of any material is the sole responsibility of the user. All materials may present unknown hazards and should be used with caution. Although certain hazards are described herein, we cannot guarantee that these are the only hazards that exist.*

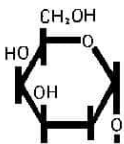

## Poly-Drill Drilling Systems

1824 - 104 Avenue, S.W.  
Calgary, Alberta, Canada T2W-OA8  
(403) 259-5112 FAX (403) 255-7185  
email: polydril@telus.net  
[www.poly-drill.com](http://www.poly-drill.com)

**poly-drill.com**



## MATERIAL SAFETY DATA SHEET/FICHE SIGNALÉTIQUE

### 1. PRODUCT IDENTIFICATION

PRODUCT TRADE NAME: Poly-Drill 133-X  
PRODUCT DESCRIPTION: LIQUID ANIONIC POLYMER  
CHEMICAL DESCRIPTION: Polymer, Surfactant(s), Water, Hydrocarbon solvent  
UPDATED: March 15, 2004

#### NFPA704M/HMIS RATING

HEALTH: 0/1	FLAMMABILITY: 1/1	REACTIVITY: 0/0	OTHER:
0=Insignificant	1=Slight 2=Moderate	3=High	4=Extreme

### 2. COMPOSITION

A liquid polymer: Evaluation of the ingredient(s) has found no ingredient(s) hazardous as per WHMIS regulations. None of the substances in this product are hazardous.

### 3. PHYSICAL DATA

Flash Point: >100°C (PMCC)  
Specific Gravity (@ 25°C.): 1.08  
Solubility in Water: Emulsifiable  
pH: 8.1 (1.0% solution)  
Freeze Point: -10 °C (14 Degrees F)  
Density (g/ml): 1.08 at 25 °C  
Physical State: Liquid  
Appearance: Blue liquid  
Odor: Hydrocarbon

Note: These physical properties are typical values for this product.

### 4. FIRE AND EXPLOSION DATA

INCOMPATIBILITY: Avoid contact with strong oxidizers (eg. Chlorine, peroxides, chromates, nitric acid, perchlorates, concentrated oxygen, permanganates) which can generate heat, fires, explosions and the release of toxic fumes.

THERMAL DECOMPOSITION PRODUCTS: In the event of combustion CO, oxides of carbon (CO<sub>x</sub>), oxides of nitrogen (NO<sub>x</sub>) may be formed. Do not breathe smoke or fumes. Wear suitable protective equipment.

### 5. FIRE FIGHTING MEASURES

FLASH POINT: >100°C (PMCC)

**EXTINGUISHING MEDIA:** Based on the NFPA guide, use dry chemical, foam, carbon dioxide or other extinguishing agent suitable for Class B fires. Use water to cool containers exposed to fire. For larger fires, use water spray or fog, thoroughly drenching the burning material.

**UNSUITABLE EXTINGUISHING MEDIA:**  
Do not use water unless flooding amounts are available.

**UNUSUAL FIRE AND EXPLOSION HAZARD:** May evolve oxides of nitrogen (NOx) under fire conditions.

## **6. HEALTH HAZARD DATA**

### **EMERGENCY OVERVIEW:**

**CAUTION:** May cause irritation to skin and eyes. Avoid contact with skin, eyes and clothing. Do not take internally.

Empty containers may contain residual product. Do not reuse container unless properly reconditioned.

**PRIMARY ROUTE(S) OF EXPOSURE:** Eye & Skin

**EYE CONTACT:** Can cause mild to moderate irritation

**SKIN CONTACT:** Can cause mild, short-lasting irritation

**SYMPTOMS OF EXPOSURE:** A review of available data does not identify any symptoms from exposure not previously mentioned.

**AGGRAVATION OF EXISTING CONDITIONS:** A review of available data does not identify any worsening of existing conditions.

## **7. EMERGENCY AND FIRST AID PROCEDURES**

**SKIN:** Wash exposed area with soap and water. If irritation or abnormalities persist, call a physician.

**EYE:** Immediately flush eyes with water for 15 minutes, if irritation or abnormalities persist, call a physician.

**INHALATION:** Remove to fresh air. If breathing becomes difficult, give oxygen and call a physician.

**INGESTION:** Do not induce vomiting: Call a physician immediately.

**CAUTION:** If unconscious, having trouble breathing or in convulsions, do not induce vomiting or give water. Call for medical assistance immediately.

## **8. HANDLING, ACCIDENTAL RELEASE MEASURES & DISPOSAL CONSIDERATIONS**

**Storage:** Keep container tightly closed when not in use.

### **DISPOSAL:**

In Ontario, the waste class under Regulation 347 is: 233L

### **SMALL SPILLS:**

Soak up spill with absorbent material. Place residues in a suitable, covered, properly labeled container. Wash affected area.

### **LARGE SPILLS:**

Contain liquid using absorbent material, by digging trenches or by dyking. Reclaim into recovery or salvage drums or tank truck for proper disposal. Contact approved waste hauler for disposal of contaminated recovered material. Dispose of material in compliance with regulations indicated.

Dispose of wastes in an approved incinerator or waste treatment/disposal site, in accordance with all applicable regulations. Do not dispose of wastes in local sewer or with normal garbage.

## ENVIRONMENTAL PRECAUTIONS

This product should NOT be directly discharged into lakes, ponds, streams, waterways or public water supplies.

As a non-hazardous liquid waste, it should be solidified with stabilizing agents (such as sand, fly ash, or cement) so that no free liquid remains before disposal to an industrial waste landfill. A non-hazardous liquid waste can also be incinerated in accordance with local, state, provincial and federal regulations.

## 9. INDUSTRIAL HYGIENE CONTROL MEASURES

### OCCUPATIONAL EXPOSURE LIMITS:

This product does not contain any substance that has an established exposure limit.

Respiratory Protection: None normally required.

For large spills, entry into large tanks, vessels or enclosed small spaces with inadequate ventilation, a positive pressure, self-contained breathing apparatus is recommended.

Ventilation: General ventilation is recommended.

Eye Protection: Safety glasses, if personally preferred

Gloves: Generally not necessary. Personal preference. Examples of impermeable gloves available on the market are neoprene, nitrile, PVC, natural rubber, viton, and butyl (compatibility studies have not been performed).

If clothing is contaminated, remove clothing and thoroughly wash the affected area. Launder contaminated clothing before reuse.

## 10. TOXICOLOGICAL PROPERTIES

### SENSITIZATION:

This product is not expected to be a sensitizer.

A "LC50-96" Pass/Fail Bioassay test. This test determines the lethality of a fluid on young aquatic organisms. The fluid fails if 50% or more of the animals are dead after 96 hours in the fluid.

96 hour static acute LC50 to Rainbow Trout = Greater than 1,000 mg/L

96 hour no observed effect concentration = 125 mg/L based on no mortality or abnormal effects

96 hour static acute LC50 to Sheepshead Minnow = Greater than 1,000 mg/L

96 hour no observed effect concentration = 1,000 mg/L (highest concentration tested) based on no mortality or abnormal effects.

96 hour static acute LC50 to Mysid Shrimp = 400 mg/L

96 hour no observed effect concentration = 180 mg/L based on no mortality or abnormal effects.

96 hour static acute LC50 to Daphnia Magna - 400 mg/L

96 hour no observed effect concentration = 56 mg/L (lowest concentration tested) based on no mortality or abnormal effects.

### Microtoxicity

The Microtox bioassay has been established as the reference test for mud additive toxicity testing.

Test Method: Luminescent Bacteria, IC50@ 15 min

Reference: Appendix 1: Microtox Bioassay Procedure, Drilling Waste Management, Guide G50. 1993. Alberta Energy and Utilities Board, Calgary, AB, Canada.

Sample: Poly Drill 1330, sample #97324-1 for test #970723, 97/05/09 by D. Lintott

Preparation: Sample was diluted to 2 g/L, which formed thick, slightly cloudy liquid. The sample was then centrifuged for 1 hour.

Test Results:

SAMPLE	TREATMENT	%CTL	IC20%	IC50	RESULT
97324-1	None	N/A	14 (9-22)	>91	PASS

The following results are for a 1% aqueous solution of product.

**CARCINOGENICITY:**

None of the substances in this product are listed as carcinogens by the International Agency for Research on Cancer (IARC), the National Toxicology Program (NTP) or the American Conference of Government Industrial Hygienists (ACGIH).

**HUMAN HAZARD CHARACTERIZATION:**

Based on our Hazard Characterization, the potential human hazard is: LOW

**ENVIRONMENTAL HAZARD AND EXPOSURE CHARACTERIZATION:**

Based on our Hazard Characterization, the potential environmental hazard is: LOW.

**11. DEPARTMENT OF TRANSPORTATION INFORMATION**

PROPER SHIPPING NAME/HAZARD CLASS MAY VARY BY PACKAGING, PROPERTIES, AND MODE OF TRANSPORTATION. TYPICAL PROPER SHIPPING NAMES FOR THIS PRODUCT ARE:

ALL TRANSPORTATION MODES: PRODUCT IS NOT REGULATED DURING TRANSPORTATION

Shipping Name: Liquid Drilling Additive

Hazard Class: Not hazardous

Cautionary Labeling: None required

**14. OTHER INFORMATION**

This information contained herein is given in good faith, but no warranty, expressed or implied is made

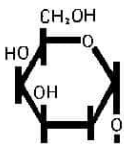

## Poly-Drill Drilling Systems

1824 - 104 Avenue, S.W.  
Calgary, Alberta, Canada T2W-OA8  
(403) 259-5112 FAX (403) 255-7185  
email: polydril@telus.net  
[www.poly-drill.com](http://www.poly-drill.com)

**poly-drill.com**



## MATERIAL SAFETY DATA SHEET/FICHE SIGNALÉTIQUE

---

### 1. PRODUCT IDENTIFICATION

PRODUCT TRADE NAME(S): Poly Drill O.B.X.  
WHMIS CLASSIFICATION: Non-regulated  
TDG Classification: Non dangerous goods  
DATE: January 17, 2004

A liquid polymer containing guar gum, mineral oil, vegetable oil, acrylamide copolymer and a surfactant: Evaluation of the ingredient(s) has found no ingredient(s) hazardous as per WHMIS regulations.

### 2. PHYSICAL DATA

Boiling Point: Not available  
Specific Gravity: 0.9 g/cm  
Solubility in Water: disperses in water(forms viscous, slippery solution).  
pH: 3.8 (1% concentration)  
Density (g/ml): Not available  
Physical State: Liquid  
Appearance and Odor: Brown. Odor slight.

### 3. FIRE AND EXPLOSION DATA

Flash Point (method used): (PMCC) greater than 100 C.  
Conditions of flammability: Very low risk.  
Hazardous combustion products: None known.  
Upper and Lower flammable limits: Not available.  
Extinguishing media: Carbon dioxide, dry chemicals, foam, in preference to water spray

### 4. REACTIVITY

Chemical stability: Stable under normal conditions.  
Hazardous Polymerization: Will not occur.  
Incompatible substances: Avoid strong oxidants such as liquid chlorine, concentrated oxygen, sodium or calcium hypo chloride.  
Hazardous decomposition products: None known

### 5. HEALTH HAZARD DATA

TOXICITY RATING: Practically non-harmful.

Routes of Exposure and Effects:

SKIN: Slight irritant: prolonged contact may cause skin irritation or dermatitis in some individuals

EYE: No effects of exposure expected with the exception of possible irritation.

INHALATION: Due to low volatility of mineral distillates a small inhalation hazard exists.

INGESTION: can cause nausea, vomiting, cramps, diarrhea  
Chronic exposure limits: None  
Sensitization of product: Not suspected to be a sensitizer.  
Teratogenicity: Not available.  
Mutagenicity: Not available.  
Carcinogenicity: None of the components of this product are listed as carcinogens by IARC and ACGIH

## 6. EMERGENCY AND FIRST AID PROCEDURES

SKIN: Wash exposed area with soap and water. Remove contaminated clothing. Launder contaminated clothing before re-use. If irritation or abnormalities persist, call a physician.

EYE: Immediately flush eyes with water for 15 minutes, lifting upper and lower lids occasionally. Get medical attention.

INHALATION: Remove to fresh air. If breathing becomes difficult, give oxygen and call a physician.

INGESTION: Do not induce vomiting: Call a physician immediately or poison control center. Never give anything by mouth to an unconscious person. Seek medical advice.

## 8. INDUSTRIAL HYGIENE CONTROL MEASURES

Respiratory Protection: None normally required.

Ventilation: If mist and/or vapors are present, use air purifying respirator or self-contained breathing apparatus, but this is rarely required.

Eye Protection: Safety glasses, if personally preferred

Gloves: Generally not necessary. Personal preference.

## 7. HANDLING AND USE PRECTIONS

Storage requirements: keep container closed when no in use. Store in a cool dry location away from oxidizing and reducing agents.

Waste Disposal: product should be disposed of in accordance with applicable local, Provincial and Federal regulations.

Steps must be taken if product is released or spilled: clean spill areas thoroughly to avoid hazardous slippery conditions.

## 8. TOXICOLOGICAL PROPERTIES

G50 Microtox Analysis prepared by HydroQual Laboratories, Calgary, AB--97/6/26 Test#970978:

Test Description	EC20	EC50	Pass/Fail
MTX	>91	>91	PASS

## 9. DEPARTMENT OF TRANSPORTATION INFORMATION

Shipping Name: Liquid Drilling Additive

Hazard Class: Not hazardous

Hazardous Substances: None

Cautionary Labeling: None required

## MATERIAL SAFETY DATA SHEET

### SECTION 1 - CHEMICAL PRODUCT AND COMPANY IDENTIFICATION

<b>Product Name:</b>	Portland Cement, GU (General use hydraulic cement, formerly Normal Portland Cement), HE (High early-strength hydraulic cement) and HS (High sulphate-resistant hydraulic cement).		
<b>CAS #:</b>	65997-15-1		
<b>Product Use:</b>	Preparation of concrete and mortar.		
<b>MSDS Information:</b>	This MSDS was produced in November, 2002, and replaces any previous versions. This MSDS covers all types of portland cement. Individual composition of constituents will vary within the range shown in Section 2.		
<b>Product Code:</b>	Not Applicable.		
<b>Chemical Family:</b>	Calcium compounds. Calcium silicate compounds and other calcium compounds containing iron and aluminum make up the majority of this product.		
<b>Chemical Name And Synonyms:</b>	Portland cement. Portland cement is also known as hydraulic cement and/or normal portland cement.		
<b>Formula:</b>	This product consists of finely ground portland cement clinker, gypsum and limestone (for some products).		
<b>Supplier/Manufacturer:</b>	Lehigh Inland Cement Limited P.O. Box 3961, Station D, 12640 - 156 Street Edmonton, Alberta, Canada, T5L 4P5		Telephone (780) 420 2500
<b>Emergency Contact Information:</b>	Lehigh Inland Cement Limited P.O. Box 3961, Station D, 12640 - 156 Street Edmonton, Alberta, Canada, T5L 4P5		Telephone (780) 420 2541

### SECTION 2 - COMPOSITION/INFORMATION ON INGREDIENTS

<b>Portland Cement Exposure Limits:</b>	ACGIH TLV-TWA	10 mg total dust/m <sup>3</sup>
	OSHA PEL-TWA	15 mg total dust/m <sup>3</sup>
	OSHA PEL-TWA	5 mg respirable dust/m <sup>3</sup>

#### Portland Cement Ingredients & Their Exposure Limits:

Ingredient	CAS#	% By Weight	ACGIH TLV-TWA	OSHA PEL-TWA
Calcium Silicates	various	60-80%	10 mg total dust/m <sup>3</sup>	15 mg total dust/m <sup>3</sup> 5 mg respirable dust/m <sup>3</sup>
Gypsum	7778-18-9	3-7%	10 mg total dust/m <sup>3</sup>	15 mg total dust/m <sup>3</sup> 5 mg respirable dust/m <sup>3</sup>
Crystalline Silica	14808-60-7	less than 0.1%	0.10 mg respirable quartz/m <sup>3</sup> NIOSH REL (8-hour TWA) = 0.05 mg respirable quartz dust/m <sup>3</sup>	(10 mg respirable dust/m <sup>3</sup> )/(percent silica+2)
Calcium Carbonate	1317-65-3	0-5%	10 mg total dust/m <sup>3</sup>	15 mg total dust/m <sup>3</sup> 5 mg respirable dust/m <sup>3</sup>
Magnesium Oxide	1309-48-4	1-4%	10 mg total dust/m <sup>3</sup>	10 mg total dust/m <sup>3</sup>
Calcium Oxide	1305-78-8	0.5-1.5%	2 mg total dust/m <sup>3</sup>	5 mg total dust/m <sup>3</sup>

#### Trace Elements:

Portland cement is made from materials mined from the earth and is processed using energy provided by fuels. Trace amounts of chemicals, some of which may be potentially harmful, might be detected during chemical analysis. For example, in addition to the ingredients listed above, portland cement may contain potassium and sodium sulfate compounds, chromium compounds (including up to 0.003% hexavalent chromium) and nickel compounds.

# MATERIAL SAFETY DATA SHEET

## SECTION 3 - HAZARDS IDENTIFICATION

### **Emergency Overview:**

Portland cement is a light gray powder that poses little immediate hazard. A single short term exposure to the dry powder is not likely to cause serious harm. However, exposure of sufficient duration to wet portland cement can cause serious, potentially irreversible tissue (skin or eye) destruction in the form of chemical (caustic) burns, including third degree burns. The same type of tissue destruction can occur if wet or moist areas of the body are exposed for sufficient duration to dry portland cement.

### **Potential Health Effects:**

- **Relevant routes of exposure are:**

Eye contact, skin contact, inhalation, and ingestion.

#### **Effects Resulting From EYE CONTACT:**

Exposure to airborne dust may cause immediate or delayed irritation or inflammation.

Eye contact by larger amounts of dry powder or splashes of wet portland cement may cause effects ranging from moderate eye irritation to chemical burns and blindness. Such exposures require immediate first aid (see Section 4) and medical attention to prevent significant damage to the eye.

#### **Effects Resulting From SKIN CONTACT:**

Discomfort or pain cannot be relied upon to alert a person to a hazardous skin exposure. Consequently, the only effective means of avoiding skin injury or illness involves minimizing skin contact, particularly contact with wet cement. Exposed persons may not feel discomfort until hours after the exposure has ended and significant injury has occurred.

Exposure to dry portland cement may cause drying of the skin with consequent mild irritation or more significant effects attributable to aggravation of other conditions. Dry portland cement contacting wet skin or exposure to moist or wet portland cement may cause more severe skin effects including thickening, cracking, or fissuring of the skin. Prolonged exposure can cause severe skin damage in the form of (caustic) chemical burns.

Some individuals may exhibit an allergic response upon exposure to portland cement, possibly due to trace amounts of chromium. The response may appear in a variety of forms ranging from a mild rash to severe skin ulcers. Persons already sensitized may react to their first contact with the product. Other persons may first experience this effect after years of contact with portland cement products.

#### **Effects Resulting From INHALATION:**

Portland cement may contain trace amounts of crystalline silica. Prolonged exposure to respirable free crystalline silica may aggravate other lung conditions. It also may cause delayed lung injury including silicosis, a disabling and potentially fatal lung disease, and/or other diseases. (Also see "Carcinogenic Potential" below.)

Exposure to portland cement may cause irritation to the moist mucous membranes of the nose, throat, and upper respiratory system. It may also leave unpleasant deposits in the nose.

#### **Effects Resulting From INGESTION:**

Although small quantities of dust are not known to be harmful, ill effects are possible if larger quantities are consumed. Portland cement should not be eaten.

- **Carcinogenic Potential:**

Portland cement is not listed as a carcinogen by NTP, OSHA, or IARC. It may, however, contain trace amounts of substances listed as carcinogens by these organizations.

Crystalline silica, a potential trace level contaminant in portland cement, is now classified by IARC as a known human carcinogen (Group 1). NTP has characterized respirable silica as "reasonably anticipated to be [a] carcinogen".

- **Medical Conditions That May Be Aggravated By Inhalation Or Dermal Exposure:**

Pre-existing upper respiratory and lung diseases.  
Unusual (hyper) sensitivity to hexavalent chromium (chromium<sup>+6</sup>) salts.

## MATERIAL SAFETY DATA SHEET

### SECTION 4 - FIRST-AID MEASURES

**Eyes:**

Immediately flush eyes thoroughly with water. Continue flushing for at least 15 minutes, including under lids, to remove all particles. Call physician immediately.

**Skin:**

Wash skin with cool water and pH-neutral soap or a mild detergent intended for use on skin. Seek medical treatment in all cases of prolonged exposure to wet cement, cement mixtures, liquids from fresh cement products, or prolonged wet skin exposure to dry cement.

**Inhalation Of Airborne Dust:**

Remove to fresh air. Seek medical help if coughing and other symptoms do not subside. ("Inhalation" of gross amounts of portland cement requires immediate medical attention.)

**Ingestion:**

Do not induce vomiting. If conscious, have the victim drink plenty of water and call a physician immediately.

### SECTION 5 - FIRE-FIGHTING MEASURES

<b>Flammability:</b>	Not Flammable.
<b>Flash Point:</b>	Not Applicable.
<b>Lower Explosive Limit:</b>	Not Applicable.
<b>Upper Explosive Limit:</b>	Not Applicable.
<b>Auto Ignition Temperature:</b>	Not Applicable.
<b>Sensitivity To Static Discharge:</b>	Not Applicable.
<b>Sensitivity To Impact:</b>	Not Applicable.
<b>Extinguishing Media:</b>	Not Applicable.
<b>Special Fire-Fighting Procedures:</b>	None.
<b>Hazardous Combustion Products:</b>	Not Applicable.
<b>Unusual Fire And Explosion Hazards:</b>	Not Applicable.

### SECTION 6 - ACCIDENTAL RELEASE MEASURES

Collect dry material using a scoop. Avoid actions that cause dust to become airborne. Avoid inhalation of dust and contact with skin. Wear appropriate personal protective equipment as described in Section 8.

Scrape up wet material and place in an appropriate container. Allow the material to "dry" before disposal. Do not attempt to wash portland cement down drains.

Dispose of waste material according to local, provincial, state and federal regulations.

### SECTION 7 - HANDLING AND STORAGE

Keep portland cement dry until used. Normal temperatures and pressures do not affect the material.

Promptly remove dusty clothing or clothing which is wet with cement fluids and launder before reuse. Wash thoroughly after exposure to dust or wet cement mixtures or fluids.

## MATERIAL SAFETY DATA SHEET

### SECTION 8 - EXPOSURE CONTROLS/PERSONAL PROTECTION

#### Eye Protection:

When engaged in activities where cement dust or wet cement or concrete could contact the eye, wear safety glasses with side shields or goggles. In extremely dusty environments and unpredictable environments, wear unvented or indirectly vented goggles to avoid eye irritation or injury. Contact lenses should not be worn when working with portland cement or fresh cement products.

#### Skin Protection:

Prevention is essential to avoiding potentially severe skin injury. Avoid contact with unhardened (wet) portland cement products. If contact occurs, promptly wash affected area with soap and water. Where prolonged exposure to unhardened portland cement products might occur, wear impervious clothing and gloves to eliminate skin contact. Where required, wear boots that are impervious to water to eliminate foot and ankle exposure.

Do not rely on barrier creams; barrier creams should not be used in place of gloves.

Periodically wash areas contacted by dry portland cement or by wet cement or concrete fluids with a pH-neutral soap. Wash again at the end of work. If irritation occurs, immediately wash the affected area and seek treatment. If clothing becomes saturated with wet concrete, it should be removed and replaced with clean dry clothing.

#### Respiratory Protection:

Avoid actions that cause dust to become airborne. Use local or general ventilation to control exposures below applicable exposure limits.

Use NIOSH/MSHA-approved (under 30 CFR 11) or NIOSH-approved (under 42 CFR 84 after July 10, 1998) respirators in poorly ventilated areas, if an applicable exposure limit is exceeded, or when dust causes discomfort or irritation.

#### Ventilation:

Use local exhaust or general dilution ventilation to control exposure within applicable limits.

### SECTION 9 - PHYSICAL AND CHEMICAL PROPERTIES

<b>Appearance:</b>	White to gray powder.
<b>Odor:</b>	No distinct odor.
<b>Odor Threshold:</b>	Not applicable.
<b>Physical State:</b>	Solid (powder).
<b>pH (as a solid):</b>	Not applicable.
<b>pH (in water) (ASTM D 1293-95):</b>	12 to 13
<b>Solubility In Water:</b>	Slightly soluble (0.1 to 1.0 %).
<b>Vapor Pressure:</b>	Not applicable.
<b>Vapor Density:</b>	Not applicable.
<b>Boiling Point:</b>	Not applicable (i.e., >1000°C).
<b>Freezing Point:</b>	Not applicable.
<b>Melting Point:</b>	Not applicable.
<b>Specific Gravity (H<sub>2</sub>O = 1.0):</b>	3.15
<b>Evaporation Rate:</b>	Not applicable.
<b>Coeff. Water/Oil Dist.:</b>	Not applicable.

### SECTION 10 - STABILITY AND REACTIVITY

<b>Stability:</b>	Stable
<b>Conditions to avoid:</b>	Unintentional contact with water.
<b>Incompatibility:</b>	Portland cement reacts with water to produce a caustic solution, pH 12 to pH 13. Wet portland cement is alkaline. As such it is incompatible with acids, ammonium salts and aluminum metal. Aluminum powder and other alkali and alkaline earth elements will react in wet mortar or concrete, liberating hydrogen gas. Portland cement dissolves in hydrofluoric acid producing corrosive silicon tetrafluoride gas. Silicates react with powerful oxidizers such as fluorine, chlorine, trifluoride and oxygen difluoride.

## MATERIAL SAFETY DATA SHEET

### SECTION 10 - STABILITY AND REACTIVITY (CONTINUED)

**Hazardous Decomposition:** Will not spontaneously occur. Adding water results in hydration and produces (caustic) calcium hydroxide.

**Hazardous Polymerization:** Will not occur.

### SECTION 11 - TOXICOLOGICAL INFORMATION

**Effects Of Acute Exposure:**

Portland cement and wet portland cement mixtures can dry the skin, cause alkali burns and irritate the eyes and upper respiratory tract. Ingestion can cause irritation of the throat.

**Effects Of Chronic Exposure:**

Portland cement dust can cause inflammation of the tissue lining the interior of the nose and the cornea (white) of the eye.

### SECTION 12 - ECOLOGICAL INFORMATION

**Ecotoxicity:** No recognized unusual toxicity to plants or animals.  
**Relevant Physical And Chemical Properties:** See Sections 9 and 10.

### SECTION 13 - DISPOSAL CONSIDERATIONS

Dispose of waste material according to local, provincial, state and federal regulations. (Since portland cement is stable, uncontaminated material may be saved for future use.)

Dispose of bags in an approved landfill or incinerator.

### SECTION 14 - TRANSPORT INFORMATION

**Hazardous materials description/proper shipping name:** Portland cement is not hazardous under the TDG Act (Canada) or DOT regulations (USA).  
**Hazard Class:** Not applicable.  
**Identification Number:** Not applicable.  
**Required Label Text:** Not applicable.  
**Hazardous substances/reportable quantities (RO):** Not applicable.

### SECTION 15 - REGULATORY INFORMATION

**Status under USDOL-OSHA Hazard Communication Rule, 29 CFR 1910.1200:**

Portland cement is considered a "hazardous chemical" under this regulation, and should be part of any hazard communication program.

**Status under CERCLA/Superfund, 40 CFR 117 and 302:**

Not listed.

**Hazard Category under SARA (Title III), Sections 311 and 312:**

Portland cement qualifies as a "hazardous substance" with delayed health effects.

**Status under SARA (Title III), Section 313:**

Not subject to reporting requirements under Section 313.

## MATERIAL SAFETY DATA SHEET

### SECTION 15 - REGULATORY INFORMATION (CONTINUED)

**Status under TSCA (as of May 1997):**

Some substances in portland cement are on the TSCA inventory list.

**Status under the Federal Hazardous Substances Act:**

Portland cement is a "hazardous substance" subject to statutes promulgated under the subject act.

**Status under California Proposition 65:**

This product contains chemicals (trace metals) known to the State of California to cause cancer, birth defects or other reproductive harm. California law requires the manufacturer to give the above warning in the absence of definitive testing to prove the defined risks do not exist.

**Status under Canadian Environmental Protection Act:**

Not listed.

**Status under WHMIS:**

Portland cement is considered to be a hazardous material under the Hazardous Products Act as defined by the Controlled Products Regulations and is therefore subject to the labeling and MSDS requirements of the Workplace Hazardous Materials Information System (WHMIS).

This product has been classified in accordance with the hazard criteria of the CPR and the MSDS contains all the information required by the CPR.

### SECTION 16 - OTHER INFORMATION

<b>Prepared By:</b>	Robin Cowdrey
<b>Approved By:</b>	Bob Rimes
<b>Approval Date or Revision Date:</b>	September 1, 2004
<b>Date Of Previous MSDS:</b>	November 1, 2002
<b>MSDS Number:</b>	Not Applicable

**Other Important Information:**

Portland cement should only be used by knowledgeable persons. A key to using the product safely requires the user to recognize that portland cement chemically reacts with water, and that some of the intermediate products of this reaction (that is, those present while a portland cement product is "setting") pose a far more severe hazard than does portland cement itself.

While the information provided in this material safety data sheet is believed to provide a useful summary of the hazards of portland cement as it is commonly used, the sheet cannot anticipate and provide all of the information that might be needed in every situation. Inexperienced product users should obtain proper training before using this product.

In particular, the data furnished in this sheet does not address hazards that may be posed by other materials mixed with portland cement to produce portland cement products. Users should review other relevant material safety data sheets before working with this portland cement or working on portland cement products, for example, portland cement concrete.

No representations or warranties with respect to the accuracy or correctness of this information, or of any kind or nature whatsoever are given, made or intended by Lehigh Inland Cement Limited. No legal responsibility whatsoever is assumed for this information, or for any injuries or damages, however caused which may result from the use of this information. This information is offered solely for informational purposes and is subject to your own independent investigation and verification.

**SECTION 1 – PRODUCT INFORMATION**

**Product Name:** Propane  
**Trade Name:** LPG (Liquified Petroleum Gas), LP-Gas  
**Chemical Formula:** C<sub>3</sub>H<sub>8</sub>

**Supplier:** Superior Propane Inc.  
 1111 - 49th Avenue N.E.  
 Calgary, AB T2E 8V2

WHMIS CLASSIFICATION  
 Class A - Compressed Gas  
 Class B, Division 1 - Flammable Gas

**Business:** (403) 730-7500

**Local Market**  
**Emergency Number:** \_\_\_\_\_  
 (Non Medical)

**Application and Use:** Propane is commonly used as a fuel for heating, cooking, automobiles, forklift trucks, crop drying and welding and cutting operations. Propane is used in industry as a refrigerant, solvent and as a chemical feedstock.

**SECTION 2 – HAZARDOUS INGREDIENTS**

COMPONENTS	CAS NO.	% Volume (v/v)	LD50
Propane	74 -98-6	90% - 99%	Not Applicable
Propylene	115 -07-1	0% - 5%	Not Applicable
Ethane	74 -84-0	0% - 5%	Not Applicable
Butane and heavier hydro carbons	106 -97-8	0% - 2.5%	Not Applicable

Occupational Exposure Limit:

Based upon animal test data, the acute toxicity of this product is expected to be inhalation: 4 hour LC50 = 280,000 ppm (Rat).  
**Note:** Composition is typical for HD-5 Propane per The Canadian General Standard Board CGSB 3.14 National Standard of Canada. Exact composition will vary from shipment to shipment.

**SECTION 3 – CHEMICAL AND PHYSICAL DATA**

**Form:** Liquid and vapour while stored under pressure.  
**Boiling Point:** -42°C @ 1 atm.  
**Freezing Point:** -188°C  
**Evaporation Rate:** Rapid (Gas at normal ambient conditions).  
**Vapour Pressure:** 1435 kPa (maximum) @ 37.8°C  
**Vapour Density:** 1.52 (Air = 1)  
**Coefficient of Water/Oil Distribution:** Not available.  
**pH:** Not available.

**Solubility in water:** Slight, 6.1% by volume @ 17.8°C  
**Specific Gravity:** 0.51 (water = 1)  
**Appearance/Odour:** Colourless liquid and vapour while stored under pressure. Colourless and odourless gas in natural state at any concentration. Commercial propane has an odourant added, ethyl mercaptan, which has an odour similar to boiling cabbage.\*  
**Odour Threshold:** 4800 ppm

\* With proper handling, transportation and storage, adding a chemical odourant such as eth-merc has proven to be a very effective warning device, but all odourants have certain limitations. The effectiveness of the odourant may be diminished by a person's sense of smell, by competing odours and by oxidation which may cause a potentially dangerous situation.

**SECTION 4 – FIRE OR EXPLOSION HAZARD**

**Flash Point:** -103.4°C  
**Method:** Closed cup.  
**Flammable Limits:** Lower 2.4%, Upper 9.5%  
**Auto Ignition Temperature:** 432°C  
**Products Evolved Due To Heat Or Combustion:** Carbon monoxide can be produced when primary air and secondary air are deficient while combustion is taking place.  
**Fire and Explosive Hazards:** Explosive air-vapour mixtures may form if allowed to leak to atmosphere.  
**Sensitivity To Impact:** No.  
**Sensitivity To Static Discharge:** Yes.

**Fire Extinguishing Precautions:** Use water spray to cool exposed cylinders or tanks. Do not extinguish fire unless the source of the escaping gas that is fueling the fire can be turned off. Fire can be extinguished with carbon dioxide and/or dry chemical (BC). Container metal shells require cooling with water to prevent flame impingement and the weakening of metal. If sufficient water is not available to protect the container shell from weakening, the area will be required to be evacuated. If gas has not ignited, liquid or vapour may be dispersed by water spray or flooding.  
**Special Fire Fighting Equipment:** Protective clothing, hose monitors, fog nozzles, self-contained breathing apparatus.

**SECTION 5 – REACTIVITY DATA**

**Stability:** Stable.  
**Conditions To Avoid:** Keep separate from oxidizing agents. Gas explodes spontaneously when mixed with chloride dioxide.  
**Incompatibility:** Remove sources of ignition and observe distance requirements for storage tanks from combustible material, drains and openings to building.

**Hazardous Decomposition Products:** Deficient primary and secondary air can produce carbon monoxide.  
**Hazardous Polymerization:** Will not occur.

## SECTION 6 – TOXICOLOGICAL PROPERTIES OF MATERIAL

### ROUTES OF ENTRY:

**Inhalation:** Simple asphyxiant. No effect at concentrations of 10,000 ppm (peak exposures). Higher concentrations may cause central nervous system disorder and/or damage. Lack of oxygen may cause dizziness, loss of coordination, weakness, fatigue, euphoria, mental confusion, blurred vision, convulsions, breathing failure, coma and death. Breathing high vapour concentrations (saturated vapours) for a few minutes may be fatal. Saturated vapours may be encountered in confined spaces and/or under conditions of poor ventilation. Avoid breathing vapours or mist.

**Skin and Eye Contact:** Exposure to vapourizing liquid may cause frostbite (cold burns) and permanent eye damage.

**Ingestion:** Not considered to be a hazard.

**Acute Exposure:** The acute toxicity of this product is expected to be inhalation: 4 hour LC50=280,000ppm (Rat).

**Chronic Exposure:** There are no reported effects from long term low level exposure.

**Sensitization to Product:** Skin–unknown, Respiratory–unknown.

**Occupational Exposure Limits:** American Conference of Governmental Industrial Hygienists (ACGIH) lists as a simple asphyxiant. ACGIH TLV: 1000 ppm.

**Carcinogenicity, Reproductive Toxicity, Teratogenicity, Mutagenicity:** No effects reported.

## SECTION 7 – PREVENTIVE MEASURES

**Eyes:** Safety glasses, are recommended when transferring product.

**Skin:** Insulated gloves required if contact with liquid or liquid cooled equipment is expected. Wear gloves and long sleeves when transferring product.

**Inhalation:** Where concentration in air would reduce the oxygen level below 18% air or exceed occupational exposure limits in section 6, self-contained breathing apparatus is required.

**Ventilation:** Explosion proof ventilation equipment required in confined spaces.

## SECTION 8 – EMERGENCY AND FIRST AID PROCEDURES

### FIRST AID:

**Eyes:** Should eye contact with liquid occur, flush eyes with lukewarm water for 15 minutes. Obtain immediate medical care.

**Skin:** In case of “Cold Burn” from contact with liquid, immediately place affected area in lukewarm water and keep at this temperature until circulation returns. If fingers or hands are frostbitten, have the victim hold his hand next to his body such as under the armpit. Obtain immediate medical care.

**Ingestion:** None considered necessary.

**Inhalation:** Remove person to fresh air. If breathing is difficult or has stopped, administer artificial respiration. Obtain immediate medical care.

### SPILL OR LEAK:

Eliminate leak if possible.

Eliminate source of ignition.

Ensure cylinder is upright.

Disperse vapours with hose streams using fog nozzles. Monitor low areas as propane is heavier than air and can settle into low areas. Remain upwind of leak. Keep people away. Prevent vapour and/or liquid from entering into sewers, basements or confined areas.

## SECTION 9 – TRANSPORTATION, HANDLING AND STORAGE

- Transport and store cylinders and tanks secured in an upright position in a ventilated space away from ignition sources (so the pressure relief valve is in contact with the vapour space of the cylinder or tank).
- Cylinders that are not in use must have the valves in the closed position and be equipped with a protective cap or guard.
- Do not store with oxidizing agents, oxygen, or chlorine cylinders.

- Empty cylinders and tanks may contain product residue. Do not pressurize, cut, heat or weld empty containers.
- Transport, handle and store according to applicable federal and provincial codes and regulations.

### Transportation of Dangerous Goods (TDG)

- TDG Classification: Flammable Gas 2.1
- TDG Shipping Name: Liquefied Petroleum Gas (Propane)
- TDG Special Provisions: 56, 90, 102
- PIN Number: UN1075

## SECTION 10 – PREPARATION

Superior Propane Inc., Regulations & Safety Department. (403) 730-7500 Date prepared: November 2001.  
Supersedes: September 1999.

The information contained herein is believed to be accurate. It is provided independently of any sale of the product. It is not intended to constitute performance information concerning the product. No express warranty, implied warranty of merchantability or fitness for a particular purpose is made with respect to the product information contained herein.



<b>WHMIS (Pictograms)</b>	<b>WHMIS (Classification)</b>	<b>Protective Clothing</b>	<b>TDG (pictograms)</b>
	<b>Not controlled</b>		

<b>Section 1. Chemical Product and Company Identification</b>	
<b>Product Name</b> <b>SNOWMOBILE MOTOR OIL</b>	<b>Code</b> 460-401-8, PSNOL
<b>Synonym</b> Not available	<b>Validated on</b> 5/28/2001.
<b>Manufacturer</b> PETRO-CANADA P.O. Box 2844 Calgary, Alberta T2P 3E3	<b>In case of Emergency</b> Petro-Canada: 403-296-3000 Canutec Transportation: 613-996-6666 Poison Control Centre: Consult local telephone directory for emergency number(s).
<b>Material Uses</b> Low ash engine oil specifically designed to lubricate two-cycle snowmobile engine	

<b>Section 2. Composition and Information on Ingredients</b>					
			<i>Exposure Limits (ACGIH)</i>		
<b>Name</b>	<b>CAS #</b>	<b>% (W/W)</b>	<b>TLV-TWA(8 h)</b>	<b>STEL</b>	<b>CEILING</b>
1) Severely hydrotreated paraffinic oil and additives.	Mixture	100	5 mg/m <sup>3</sup> (oil mist)	10 mg/m <sup>3</sup> (oil mist)	Not established
<b>Manufacturer Recommendation</b>	Not applicable				
<b>Other Exposure Limits</b>	Consult local, state, provincial or territory authorities for acceptable exposure limits.				

<b>Section 3. Hazards Identification.</b>	
<b>Potential Health Effects</b>	Non irritating to slight transient irritation to skin and eyes, but no permanent damage. Relatively non-toxic via ingestion. This product has a low vapour pressure and is not expected to present an inhalation exposure at ambient conditions. Upon heating to high temperatures, or mechanical actions which may produce vapours or mists, inhalation of product may cause irritation of the breathing passages. For more information, refer to Section 11.

<b>Section 4. First Aid Measures</b>	
<b>Eye Contact</b>	IMMEDIATELY flush eyes with running water for at least 15 minutes, keeping eyelids open. Seek medical attention.
<b>Skin Contact</b>	Remove contaminated clothing - launder before reuse. Wash gently and thoroughly the contaminated skin with running water and non-abrasive soap. Seek medical attention.
<b>Inhalation</b>	Evacuate the victim to a safe area as soon as possible. If the victim is not breathing, perform artificial respiration. Allow the victim to rest in a well ventilated area. Seek medical attention.
<b>Ingestion</b>	DO NOT induce vomiting because of danger of aspirating liquid into lungs. Seek medical attention.
<b>Note to Physician</b>	Not available

<b>Section 5. Fire-fighting Measures</b>			
<b>Flammability</b>	May be combustible at high temperature.	<b>Flammable Limits</b>	Not available
<b>Flash Points</b>	OPEN CUP: 152°C (305.6°F) (Cleveland)	<b>Auto-Ignition Temperature</b>	Not available
<b>Fire Hazards in Presence of Various Substances</b>	Low fire hazard. This material must be heated before ignition will occur.	<b>Explosion Hazards in Presence of Various Substances</b>	Do not cut, weld, heat, drill or pressurize empty container. Containers may explode in heat of fire.
<b>Products of Combustion</b>	Carbon oxides (CO, CO <sub>2</sub> ), nitrogen oxides (NO <sub>x</sub> ), sulphur oxides (SO <sub>x</sub> ), smoke and irritating vapours as products of incomplete combustion.		
<b>Fire Fighting Media and Instructions</b>	NAERG96, GUIDE 171, Substances (low to moderate hazard). If tank, rail car or tank truck is involved in a fire, ISOLATE for 800 meters (0.5 mile) in all directions; also, consider initial evacuation for 800 meters (0.5 mile) in all directions. Shut off fuel to fire if it is possible to do so without hazard. If this is impossible, withdraw from area and let fire burn out under controlled conditions. Withdraw immediately in case of rising sound from venting safety device or any discolouration of tank due to fire. Cool containing vessels with water spray in order to prevent pressure build-up, autoignition or explosion. SMALL FIRE: use DRY chemicals, foam, water spray or CO <sub>2</sub> . LARGE FIRE: use water spray, fog or foam. For small outdoor fires, portable fire extinguishers may be used, and self contained breathing apparatus (SCBA) may not be required. For all indoor fires and any significant outdoor fires, SCBA is required. Respiratory and eye protection are required for fire fighting personnel.		

**Section 6. Accidental Release Measures**

<b>Material Release or Spill</b>	NAERG96, GUIDE 171, Substances (low to moderate hazard). ELIMINATE ALL IGNITION SOURCES. Avoid contact. Stop leak if without risk. Contain spill. Absorb with inert absorbents, dry clay, or diatomaceous earth. Avoid inhaling dust of diatomaceous earth for it may contain silica in very fine particle size, making this a potential respiratory hazard. Place used absorbent in closed metal containers for later disposal or burn absorbent in a suitable combustion chamber. DO NOT FLUSH TO SEWERS, STREAMS OR OTHER BODIES OF WATER. Check with applicable jurisdiction for specific disposal requirements of spilled material and empty containers. Notify the appropriate authorities immediately.
----------------------------------	---

**Section 7. Handling and Storage**

<b>Handling</b>	Avoid inhalation and skin contact especially when handling used oil. Keep away from sources of ignition. DO NOT reuse empty containers without commercial cleaning or reconditioning. Practice good personal hygiene. Wash hands after handling and before eating. Launder work clothes frequently. Discard saturated leather goods.
<b>Storage</b>	Store in tightly closed containers in cool, dry, isolated, well-ventilated area, and away from incompatibles.

**Section 8. Exposure Controls/Personal Protection**

<b>Engineering Controls</b>	For normal application, special ventilation is not necessary. If user's operations generate vapours or mist, use ventilation to keep exposure to airborne contaminants below the exposure limit. Make-up air should always be supplied to balance air removed by exhaust ventilation. Ensure that eyewash station and safety shower are close to work-station.
<b>Personal Protection -</b>	<b>The selection of personal protective equipment varies, depending upon conditions of use.</b>
<b>Eyes</b>	Eye protection (i.e., safety glasses, safety goggles and/or face shield) should be determined based on conditions of use. If product is used in an application where splashing may occur, the use of safety goggles and/or a face shield should be considered.
<b>Body</b>	Wear appropriate clothing to prevent skin contact. As a minimum long sleeves and trousers should be worn.
<b>Respiratory</b>	Where concentrations in air may exceed the occupational exposure limits given in Section 2 (and those applicable to your area) and where engineering, work practices or other means of exposure reduction are not adequate, NIOSH approved respirators may be necessary to prevent overexposure by inhalation.
<b>Hands</b>	Wear appropriate chemically protective gloves. When handling hot product ensure gloves are heat resistant and insulated.
<b>Feet</b>	Wear appropriate footwear to prevent product from coming in contact with feet and skin.

**Section 9. Physical and Chemical Properties**

<b>Physical State and Appearance</b>	Viscous liquid.	<b>Viscosity</b>	21.1 cSt @ 40°C, 4.5 cSt @ 100°C, VI=127.
<b>Colour</b>	Blue-green	<b>Pour Point</b>	<-54°C
<b>Odour</b>	Mild petroleum oil like.	<b>Softening Point</b>	Not applicable.
<b>Odour Threshold</b>	Not available	<b>Dropping Point</b>	Not applicable.
<b>Boiling Point</b>	Not available	<b>Penetration</b>	Not applicable.
<b>Density</b>	0.88 kg/L @ 15°C (59°F).	<b>Oil / Water Dist. Coefficient</b>	Not available
<b>Vapour Density</b>	Not available	<b>Ionicity (in water)</b>	Not available
<b>Vapour Pressure</b>	Negligible at ambient temperature and pressure.	<b>Dispersion Properties</b>	Not available
<b>Volatility</b>	Non-volatile.	<b>Solubility</b>	Insoluble in water.

**Section 10. Stability and Reactivity**

<b>Corrosivity</b>	Not available		
<b>Stability</b>	The product is stable under normal handling and storage conditions.	<b>Hazardous Polymerization</b>	Will not occur under normal working conditions.
<b>Incompatible Substances / Conditions to Avoid</b>	Reactive with oxidizing agents, reducing agents and acids.	<b>Decomposition Products</b>	May release CO <sub>x</sub> , NO <sub>x</sub> , aldehydes, methacrylate monomers, smoke and irritating vapours when heated to decomposition.

**Section 11. Toxicological Information**

<b>Routes of Entry</b>	Skin contact, eye contact, inhalation and ingestion.
<b>Acute Lethality</b>	Based on toxicity of components. Acute oral toxicity (LD50): >5000 mg/kg (rat). Acute dermal toxicity (LD50): >2000 mg/kg (rabbit). Acute inhalation toxicity (LC50): >2500 mg/m <sup>3</sup> /4h (rat).
<b>Chronic or Other Toxic Effects</b>	
Dermal Route:	Prolonged or repeated contact may cause skin irritation characterized by dermatitis or oil acne.

Inhalation Route:	Negligible breathing hazard at normal temperatures (up to 38°C) or recommended blending temperatures. Elevated temperatures or mechanical action may form vapours, mists or fumes. Inhalation of oil mists or vapours from hot oil may cause irritation of the upper respiratory tract.
Oral Route:	Low toxicity; has laxative effect.
Eye Irritation/Inflammation:	Repeated or prolonged contact may cause transient irritation, but no permanent damage.
Immunotoxicity:	Not available
Skin Sensitization:	This product is not expected to be a skin sensitizer, based on the available data and the known hazards of the components.
Respiratory Tract Sensitization:	This product is not expected to be a respiratory tract sensitizer, based on the available data and the known hazards of the components.
Mutagenic:	Based on actual test results of base oils and results of similar products, severely hydrotreated base oils give negative results when tested for: (a) Salmonella Typhimurium TA98 using the Modified Ames Assay for Petroleum Product; (b) Salmonella-Escherichia coli/Mammalian-Microsome Reverse Mutation Assay (Ames test) with a Confirmatory Assay; (c) Structural Chromosomal Aberrations in Chinese Hamster Ovary (CHO) Cells.
Reproductive Toxicity:	This product is not expected to be a reproductive hazard, based on the available data and the known hazards of the components.
Teratogenicity/Embryotoxicity:	This product is not expected to be a teratogen or an embryotoxin, based on the available data and the known hazards of the components.
Carcinogenicity (ACGIH):	This product is not known to contain any chemicals at reportable quantities that are listed as A1 or A2 carcinogens by ACGIH.
Carcinogenicity (IARC):	This product is not known to contain any chemicals at reportable quantities that are listed as group 1, 2A or 2B carcinogens by IARC.
Carcinogenicity (NTP):	This product is not known to contain any chemicals at reportable quantities that are listed as carcinogens by NTP.
Carcinogenicity (IRIS):	Not available
Carcinogenicity (OSHA):	This product is not known to contain any chemicals at reportable quantities that are listed as carcinogens by OSHA.
<b>Other Considerations</b>	No additional remark.

**Section 12. Ecological Information**

<b>Environmental Fate</b>	Not available	<b>Persistence/ Bioaccumulation Potential</b>	Not available
<b>BOD5 and COD</b>	Not available	<b>Products of Biodegradation</b>	Not available
<b>Additional Remarks</b>	No additional remark.		

**Section 13. Disposal Considerations**



<b>Waste Disposal</b>	Spent/used/waste oil may meet the requirements of a hazardous waste. Consult your local or regional authorities. Preferred waste management priorities are: (1) recycle or reprocess; (2) incineration with energy recovery; (3) disposal at licensed waste disposal facility. Ensure that disposal or reprocessing is in compliance with government requirements and local disposal regulations.
-----------------------	---

**Section 14. Transport Information**

<b>TDG Classification</b>	Not controlled under TDG (Canada).	<b>Special Provisions for Transport</b>	Not applicable.
---------------------------	------------------------------------	---	-----------------

**Section 15. Regulatory Information**

<b>Other Regulations</b>	<p>This product is acceptable for use under the provisions of WHMIS-CPR. All components of this formulation are listed on the CEPA-DSL (Domestic Substances List).</p> <p>All components of this formulation are listed on the US EPA-TSCA Inventory.</p> <p>All components of this product are on the European Inventory of Existing Commercial Chemical Substances (EINECS).</p> <p>This product has been classified in accordance with the hazard criteria of the Controlled Products Regulations (CPR) and the MSDS contains all of the information required by the CPR.</p> <p>Please contact Product Safety for more information.</p>		
<b>DSD/DPD (Europe)</b>	Not classified under the Dangerous Substances or Dangerous Preparations Directives.	<b>HCS (U.S.A.)</b>	Not controlled under the HCS (United States).

<b>ADR (Europe)</b> <b>(Pictograms)</b> 		<b>DOT (U.S.A)</b> <b>(Pictograms)</b> 	
<b>HMIS (U.S.A.)</b>	<b>Health Hazard</b> (1)	<b>NFPA (U.S.A.)</b>	
	<b>Fire Hazard</b> (1)		<b>Rating</b>
	<b>Reactivity</b> (0)		0 Insignificant 1 Slight 2 Moderate 3 High 4 Extreme
	<b>Personal Protection</b> (B)		

**Section 16. Other Information**

**References** Available upon request.  
 \* Marque de commerce de Petro-Canada - Trademark

**Glossary**

- |   |   |
|---|---|
| ACGIH - American Conference of Governmental Industrial Hygienists<br>ADR - Agreement on Dangerous goods by Road (Europe)<br>ASTM - American Society for Testing and Materials (<br>BOD5 - Biological Oxygen Demand in 5 days<br>CAN/CGA B149.2 Propane Installation Code<br>CAS - Chemical Abstract Services<br>CEPA - Canadian Environmental Protection Act<br>CERCLA - Comprehensive Environmental Response, Compensation and Liability Act<br>CFR - Code of Federal Regulations<br>CHIP - Chemicals Hazard Information and Packaging Approved Supply List<br>COD5 - Chemical Oxygen Demand in 5 days<br>CPR - Controlled Products Regulations<br>DOT - Department of Transport<br>DSCL - Dangerous Substances Classification and Labeling (Europe)<br>DSD/DPD - Dangerous Substances or Dangerous Preparations Directives (Europe)<br>DSL - Domestic Substance List<br>EEC/EU - European Economic Community/European Union<br>EINECS - European Inventory of Existing Commercial Chemical Substances<br>EPCRA - Emergency Planning and Community Right to Know Act<br>FDA - Food and Drug Administration<br>FIFRA - Federal Insecticide, Fungicide and Rodenticide Act<br>HCS - Hazardous Communication System<br>HMIS - Hazardous Material Information System<br>IARC - International Agency for Research on Cancer | IRIS - Integrated Risk Information System<br>LD50/LC50 - Lethal Dose/Concentration Kill 50%<br>LDLo/LCLo - Lowest Published Lethal Dose/Concentration<br>NAERG'96 - North American Emergency Response Guide Book (1996)<br>NFPA - National Fire Prevention Association<br>NIOSH - National Institute for Occupational Safety & Health<br>NPRI - National Pollutant Release Inventory<br>NSNR - New Substances Notification Regulations (Canada)<br>NTP - National Toxicology Program<br>OSHA - Occupational Safety & Health Administration<br>PEL - Permissible Exposure Limit<br>RCRA - Resource Conservation and Recovery Act<br>SARA - Superfund Amendments and Reorganization Act<br>SD - Single Dose<br>STEL - Short Term Exposure Limit (15 minutes)<br>TDG - Transportation Dangerous Goods (Canada)<br>TDLo/TCLo - Lowest Published Toxic Dose/Concentration<br>TLm - Median Tolerance Limit<br>TLV-TWA - Threshold Limit Value-Time Weighted Average<br>TSCA - Toxic Substances Control Act<br>USEPA - United States Environmental Protection Agency<br>USP - United States Pharmacopoeia<br>WHMIS - Workplace Hazardous Material Information System |
|---|---|

**For Copy of MSDS**

**Lubricants:**  
**Western Canada, telephone: 1-800-661-1199; fax: (780) 464-9564**  
**Ontario & Central Canada, telephone: 1-800-268-5850 and (905) 822-4222; fax:**  
**1-800-201-6285**  
**Quebec & Eastern Canada, telephone: 1-800-576-1686; fax: 800-201-6285**

**For Product Safety Information: (905) 804-4752**

**Prepared by Product Safety - TAR on 5/28/2001.**

**Data entry by Product Safety - JDW.**

*To the best of our knowledge, the information contained herein is accurate. However, neither the above named supplier nor any of its subsidiaries assumes any liability whatsoever for the accuracy or completeness of the information contained herein. Final determination of suitability of any material is the sole responsibility of the user. All materials may present unknown hazards and should be used with caution. Although certain hazards are described herein, we cannot guarantee that these are the only hazards that exist.*

## SECTION I-MATERIAL IDENTIFICATION AND USE

Material Name/Identifier:	Supreme Fuel Injector G.L.A.F. & Conditioner	Stock No.	409/412/414/415/418
Manufacturer's Name:	Kleen-Flo Tumbler Industries Ltd	Street Address:	75 Advance Blvd.
City:	Brampton	Province:	Ontario
Postal Code:	L6T 4N1	Emergency Phone #:	(905) 793-4311
Chemical Name:	N/A (mixture)	Chemical Family:	Blend of aliphatic alcohol
Chemical Formula:	N/A	Trade Names & Synonyms:	& aromatic hydrocarbons
Material Use:	Solvent/Cleaner	Molecular Weight:	N/A

## SECTION II-HAZARDOUS INGREDIENTS OF MATERIAL

Hazardous Ingredients	C.A.S.	Approximate Concentration	LD50 Species & Route	LC50 Species & Route
2-propanol	67-63-0	60-90%	4.72 g/kg rat-oral	>12000 ppm (8hr) rat-inh.
xylene	1330-20-7	10-30%	4300 mg/kg rabbit-derma	> 6700 ppm (4hr) rat-inh.
ethyl benzene	100-41-4	1-5%	3.5 g/kg rat-oral	N/A

## SECTION III-PHYSICAL DATA FOR MATERIAL

Physical State:	Liquid	Odour/Appearance:	Alcohol odour; clear, red liquid
Specific Gravity:	0.8 @15°C	Odour Threshold(p.p.m.):	N/A
Boiling Point:	82-137°C	Evaporation Rate:	N/A
Freezing Point:	N/A	Solubility in Water:	40%
% Volatile(by volume):	100%	Vapour Pressure(mm)Hg:	4.4 kPa @ 20°C
Vapour Density(Air=1):	2.2	Coefficient of Water/Oil Distribut:	N/E
pH	N.Ap.		

## SECTION IV-FIRE AND EXPLOSION HAZARD OF MATERIAL

Flammability Yes/No	Yes	If yes under which conditions:	heat, open flame and sparks
Auto Ignition Temperature:	N/A	Means of Extinction:	carbon dioxide, alcohol foam
Flashpoint and Method:	11°C TCC		Carbon dioxide or dry chemical for small fires.
			Hazardous Combustion Products:carbon monoxide and carbon dioxide
Upper Flammable limit		Lower Flammable Limit(% by volume):	2%
(% by volume):	12%		
Explosion Data:	Sensitivity ot mechanical impact: Yes	Sensitivity to Static Discharge: Electrical & mechanical	
			equipment should be explosion proof.

## SECTION V-REACTIVITY DATA

Chemical Stability Yes/No:	Yes	If NO under which conditions?	N.Ap.
Incompatibility to Other Substances Yes/No:	Yes	If so which ones?	strong oxidizing compounds. May react with aluminum at high temperature.
Reactivity and under what conditions?			Normally stable, but can become unstable at elevated temperatures & pressure
Hazardous Decomposition Products:			Carbon monoxide, carbon dioxide produced upon combustion.

N/E: not established

N.Ap.: not applicable

N/A: not available

**SECTION VI-TOXICOLOGICAL PROPERTIES OF PRODUCT**

Route of Entry: ALL Routes	--SKIN CONTACT --SKIN ABSORPTION --EYE CONTACT --INHALATION --INGESTION			
Effects of Acute Exposure:	Slight eye irritation. May cause headache, dizziness, nausea, drowsiness and central nervous system depression.			
Effects of Chronic Exposure:	High exposure to dimethylbenzene in some animal studies have been reported to cause health effects on developing embryo/fetus. Their effects were often at levels toxic to the mother. The significance of these findings to humans has not been determined.			
LD 50 of Product:	5840 mg/kg rat-oral	LC 50 of Product:	> 12000 ppm (8hr) rat	
Irritancy of Product:	Skin and eye irritant	Exposure Limits of Product:	400 ppm- I.P.A.	
Sensitization of Product:	N/A	2-propanol- 100 ppm, xylene- 100 ppm		
		Toxicologically Synergistic Materials:	N/A	
--CARCINOGENICITY --REPRODUCTIVE EFFECTS --TERATOGENICITY --MUTAGENICITY				none known

**SECTION VII-PREVENTIVE MEASURES**

Personal Protective Equipment to be used:

Gloves(specify):	Nitrile, Viton, Polyethylene	Eye(specify):	Chemical safety glasses
Respiratory(specify):	Organic canister mask	Clothing:	Not required
Respiratory Protection:	If used indoors or on a continuous basis, use of cartridge type respirator is recommended		
Engineering Controls:	To maintain TLV; electrical and mechanical equipment should b spark proof.		
Leak and Spill Procedure:	Dry and contain spill. Soak residue with natural absorbent.		
Waste Disposal:	Incinerate or dispose of at an approved waste disposal facility.		
Storage Requirements:	Keep in a cool place.		
Handling Procedures and Equipment:	Handle with care. Keep away from children. Do not inhale or ingest.		
TDG Classification:	#409 & 412: Consumer commodity #414 & 415 & 418: Flammable liquids, N.O.S.(2-propanol solution), Class 3, UN1993,Pkg. Grp. II		
WHMIS Classification:	Consumer Commodity #409/412; Class B2, D2B & D2A for #414, 415 &418		
Domestic substance list:	All components of this product are either on the DSL or exempt.		

**SECTION VIII-FIRST AID MEASURES**

Eye:	Wash with water for at least 15 minutes.
Skin:	Wash with soap and water.
Inhalation:	Move patient to fresh air and restore breathing if required. Call a physician.
Ingestion:	Contains petroleum distillate. Do NOT induce vomiting. Guard against aspiration. Seek medical help.

**SECTION IX-PREPARATION DATE OF M.S.D.S.**

Additional Info/Comments:		Sources Used: NOISH Registry of Toxic Effects of Chemical Sub
Phone Number:	(905) 793-4311	Prepared By: Quality Control Laboratory
Date:	March 3, 2003	Kleen-Flo Tumbler Industries Limited

**THIS SHEET SUPERSEDES ANY OTHER M.S.D.S. PREVIOUSLY PREPARED**

N/A: not available

N/E: not established



# Material Safety Data Sheet

WHMIS (Pictograms)	WHMIS (Classification)	Protective Clothing	TDG (pictograms)
	<b>Not controlled</b>		

<b>Section 1. Chemical Product and Company Identification</b>	
<b>Product Name</b>	<b>TOOL JOINT COMPOUND</b>
<b>Synonym</b>	Not available.
<b>Manufacturer</b>	PETRO-CANADA P.O. Box 2844 Calgary, Alberta T2P 3E3
<b>Material Uses</b>	Tool Joint Compound is used in drilling operations as a thread compound for rotary shouldered pipe connections to prevent galling and to provide a positive seal against drilling mud pressure.
<b>Code</b>	650-774, TOOL
<b>DSL</b>	See Section 15
<b>TSCA</b>	See Section 15
<b>In case of Emergency</b>	Petro-Canada: 403-296-3000 Canutec Transportation: 613-996-6666 Poison Control Centre: Consult local telephone directory for emergency number(s).

<b>Section 2. Composition and Information on Ingredients</b>					
			<i>Exposure Limits (ACGIH)</i>		
Name	CAS #	% (W/W)	TLV-TWA(8 h)	STEL	CEILING
1) Proprietary ingredients.	Not available.	≥90	Not available.	Not available.	Not available.
2) Mica	12001-26-2	≤10	3 mg/m <sup>3</sup>	Not established	Not established

<b>Section 3. Hazards Identification.</b>	
<b>Potential Health Effects</b>	Non irritating to slight transient irritation to skin and eyes, but no permanent damage. Relatively non-toxic via ingestion. This product has a low vapour pressure and is not expected to present an inhalation exposure at ambient conditions. Upon heating to high temperatures, or mechanical actions which may produce vapours or mists, inhalation of product may cause irritation of the breathing passages. For more information, refer to Section 11.

<b>Section 4. First Aid Measures</b>	
<b>Eye Contact</b>	IMMEDIATELY flush eyes with running water for at least 15 minutes, keeping eyelids open. Seek medical attention.
<b>Skin Contact</b>	Remove contaminated clothing - launder before reuse. Wash gently and thoroughly the contaminated skin with running water and non-abrasive soap. High pressure grease gun is capable of injecting grease through the skin. Grease gun injuries require immediate physician assessment. Seek medical attention.
<b>Inhalation</b>	Evacuate the victim to a safe area as soon as possible. If the victim is not breathing, perform artificial respiration. Allow the victim to rest in a well ventilated area. Seek medical attention.
<b>Ingestion</b>	DO NOT induce vomiting because of danger of aspirating liquid into lungs. Seek medical attention.
<b>Note to Physician</b>	Not available

<b>Section 5. Fire-fighting Measures</b>	
<b>Flammability</b>	May be combustible at high temperature.
<b>Flash Points</b>	Mineral Oil Blend: OPEN CUP: 250°C (482°F) (Cleveland)
<b>Fire Hazards in Presence of Various Substances</b>	Low fire hazard. This material must be heated before ignition will occur.
<b>Products of Combustion</b>	Carbon oxides (CO, CO <sub>2</sub> ), nitrogen oxides (NO <sub>x</sub> ), sulphur oxides (SO <sub>x</sub> ), hydrocarbons, metal oxides, smoke and irritating vapours as products of incomplete combustion.
<b>Fire Fighting Media and Instructions</b>	NAERG96, GUIDE 171, Substances (low to moderate hazard). If tank, rail car or tank truck is involved in a fire, ISOLATE for 800 meters (0.5 mile) in all directions; also, consider initial evacuation for 800 meters (0.5 mile) in all directions. Shut off fuel to fire if it is possible to do so without hazard. If this is impossible, withdraw from area and let fire burn out under controlled conditions. Withdraw immediately in case of rising sound from venting safety device or any discolouration of tank due to fire. Cool containing vessels with water spray in order to prevent pressure build-up, autoignition or explosion. SMALL FIRE: use DRY chemicals, foam, water spray or CO <sub>2</sub> . LARGE FIRE: use water spray, fog or foam. For small outdoor fires, portable fire extinguishers may be used, and self contained breathing apparatus (SCBA) may not be required. For all indoor fires and any significant outdoor fires, SCBA is required. Respiratory and eye protection are required for fire fighting personnel.
<b>Flammable Limits</b>	Lower: 0.9%; Upper: 7%
<b>Auto-Ignition Temperature</b>	>260°C (500°F)
<b>Explosion Hazards in Presence of Various Substances</b>	Do not cut, weld, heat, drill or pressurize empty container. Containers may explode in heat of fire.

**Section 6. Accidental Release Measures**

<b>Material Release or Spill</b>	NAERG96, GUIDE 171, Substances (low to moderate hazard). ELIMINATE ALL IGNITION SOURCES. Avoid contact. Stop leak if without risk. Contain spill. Absorb with inert absorbents, dry clay, or diatomaceous earth. Avoid inhaling dust of diatomaceous earth for it may contain silica in very fine particle size, making this a potential respiratory hazard. Place used absorbent in closed metal containers for later disposal or burn absorbent in a suitable combustion chamber. DO NOT FLUSH TO SEWERS, STREAMS OR OTHER BODIES OF WATER. Check with applicable jurisdiction for specific disposal requirements of spilled material and empty containers. Notify the appropriate authorities immediately.
----------------------------------	---

**Section 7. Handling and Storage**

<b>Handling</b>	Keep away from sources of ignition. DO NOT reuse empty containers without commercial cleaning or reconditioning. Practice good personal hygiene. Wash hands after handling and before eating. Launder work clothes frequently. Discard saturated leather goods.
<b>Storage</b>	Store in tightly closed containers in cool, dry, isolated, well-ventilated area, and away from incompatibles.

**Section 8. Exposure Controls/Personal Protection**

<b>Engineering Controls</b>	For normal application, special ventilation is not necessary. If user's operations generate vapours or mist, use ventilation to keep exposure to airborne contaminants below the exposure limit. Make-up air should always be supplied to balance air removed by exhaust ventilation. Ensure that eyewash station and safety shower are close to work-station.
<b>Personal Protection - The selection of personal protective equipment varies, depending upon conditions of use.</b>	
<b>Eyes</b>	Eye protection (i.e., safety glasses, safety goggles and/or face shield) should be determined based on conditions of use. If product is used in an application where splashing may occur, the use of safety goggles and/or a face shield should be considered.
<b>Body</b>	Wear appropriate clothing to prevent skin contact. As a minimum long sleeves and trousers should be worn.
<b>Respiratory</b>	Where concentrations in air may exceed the occupational exposure limits given in Section 2 (and those applicable to your area) and where engineering, work practices or other means of exposure reduction are not adequate, NIOSH approved respirators may be necessary to prevent overexposure by inhalation.
<b>Hands</b>	Wear appropriate chemically protective gloves. When handling hot product ensure gloves are heat resistant and insulated.
<b>Feet</b>	Wear appropriate footwear to prevent product from coming in contact with feet and skin.
<b>Exposure Limits</b>	Consult local authorities for acceptable exposure limits. This product is not expected to form a mist based on its properties and expected use.

**Section 9. Physical and Chemical Properties**

<b>Physical State and Appearance</b>	Smooth buttery paste.	<b>Viscosity</b>	Mineral Oil Blend: 103.3 cSt @ 40°C, 11.5 cSt @ 100°C, VI=98
<b>Colour</b>	Grey.	<b>Pour Point</b>	Mineral Oil Blend: -15°C
<b>Odour</b>	Mild petroleum odour.	<b>Softening Point</b>	Not available.
<b>Odour Threshold</b>	Not available.	<b>Dropping Point</b>	196°C
<b>Boiling Point</b>	<316°C (600°F)	<b>Penetration</b>	280 (60 strokes)
<b>Specific Gravity</b>	Mineral Oil Blend: 0.8741 kg/L @ 15°C (59°F).	<b>Oil / Water Dist. Coeff.</b>	Not available.
<b>Vapor Density</b>	Not available.	<b>Ionicity (in water)</b>	Not available.
<b>Vapor Pressure</b>	Negligible at ambient temperature and pressure.	<b>Dispersion Properties</b>	Not available.
<b>Volatility</b>	Non-volatile	<b>Solubility</b>	Insoluble in water.

**Section 10. Stability and Reactivity**

<b>Corrosivity</b>	Not available.		
<b>Stability</b>	The product is stable under normal handling and storage conditions.	<b>Hazardous Polymerization</b>	Will not occur under normal working conditions.
<b>Incompatible Substances / Conditions to Avoid</b>	Reactive with oxidizing agents and acids.	<b>Decomposition Products</b>	May release COx, NOx, SOx, hydrocarbons, metal oxides, smoke and irritating vapours when heated to decomposition.

**Section 11. Toxicological Information**

<b>Routes of Entry</b>	Skin contact, eye contact, inhalation, and ingestion.		
<b>Acute Lethality</b>	Not available.		
<b>Chronic or Other Toxic Effects</b>	<p><b>Dermal Route:</b> Prolonged or repeated contact may cause skin irritation characterized by dermatitis or oil acne.</p> <p><b>Inhalation Route:</b> Negligible breathing hazard at normal temperatures (up to 38°C) or recommended blending temperatures. Elevated temperatures or mechanical action may form vapours, mists or fumes. Inhalation of oil mists or vapours from hot oil may cause irritation of the upper respiratory tract.</p> <p><b>Oral Route:</b> Low toxicity; has laxative effect.</p>		

Continued on Next Page

Available in French

Eye Irritation/Inflammation:	Repeated or prolonged contact may cause transient irritation, but no permanent damage.
Immunotoxicity:	Not available.
Skin Sensitization:	This product is not expected to be a skin sensitizer, based on the available data and the known hazards of the components.
Respiratory Tract Sensitization:	This product is not expected to be a respiratory tract sensitizer, based on the available data and the known hazards of the components.
Mutagenic:	This product is not expected to be a mutagen, based on the available data and the known hazards of the components.
Reproductive Toxicity:	This product is not expected to be a reproductive hazard, based on the available data and the known hazards of the components.
Teratogenicity/Embryotoxicity:	This product is not expected to be a teratogen or an embryotoxin, based on the available data and the known hazards of the components.
Carcinogenicity (ACGIH):	Not available.
Carcinogenicity (IARC):	This product is not known to contain any chemicals at reportable quantities that are listed as group 1, 2A or 2B carcinogens by IARC.
Carcinogenicity (NTP):	This product is not known to contain any chemicals at reportable quantities that are listed as carcinogens by NTP.
Carcinogenicity (IRIS):	Not available.
Carcinogenicity (OSHA):	This product is not known to contain any chemicals at reportable quantities that are listed as carcinogens by OSHA.
<b>Other Considerations</b>	No additional remark.

**Section 12. Ecological Information**

<b>Environmental Fate</b>	Not available.	<b>Persistence/ Bioaccumulation Potential</b>	Not available
<b>BOD5 and COD</b>	Not available.	<b>Products of Biodegradation</b>	Not available.
<b>Additional Remarks</b>	No additional remark.		



**Section 13. Disposal Considerations**

<b>Waste Disposal</b>	Preferred waste management priorities are: (1) recycle or reprocess; (2) incineration with energy recovery; (3) disposal at licensed waste disposal facility. Ensure that disposal or reprocessing is in compliance with government requirements and local disposal regulations. Consult your local or regional authorities.
-----------------------	--

**Section 14. Transport Information**

<b>TDG Classification</b>	Not controlled under TDG (Canada).	<b>Special Provisions for Transport</b>	Not applicable.
---------------------------	------------------------------------	---	-----------------

**Section 15. Regulatory Information**

<b>Other Regulations</b>	<p>This product is acceptable for use under the provisions of WHMIS-CPR. All components of this formulation are listed on the CEPA-DSL (Domestic Substances List).</p> <p>All components of this formulation are listed on the US EPA-TSCA Inventory.</p> <p>This product has been classified in accordance with the hazard criteria of the Controlled Products Regulations (CPR) and the MSDS contains all of the information required by the CPR.</p> <p>Please contact Product Safety for more information.</p>										
<b>DSD/DPD (Europe)</b>	Not evaluated.										
<b>DSD/DPD (Europe) (Pictograms)</b>	NOT EVALUATED FOR EUROPEAN TRANSPORT  NON ÉVALUÉ POUR LE TRANSPORT EUROPÉEN.	<b>DOT (U.S.A) (Pictograms)</b>									
<b>HMIS (U.S.A.)</b>	<table border="1"> <tr><td>Health Hazard</td><td>1</td></tr> <tr><td>Fire Hazard</td><td>1</td></tr> <tr><td>Reactivity</td><td>1</td></tr> <tr><td>Personal Protection</td><td>B</td></tr> </table>	Health Hazard	1	Fire Hazard	1	Reactivity	1	Personal Protection	B	<b>NFPA (U.S.A.)</b>	Health  Fire Hazard Reactivity Specific hazard
Health Hazard	1										
Fire Hazard	1										
Reactivity	1										
Personal Protection	B										

**Section 16. Other Information**

**References** Available upon request.  
 \* Marque de commerce de Petro-Canada - Trademark

**Glossary**

ACGIH - American Conference of Governmental Industrial Hygienists	IRIS - Integrated Risk Information System
ADR - Agreement on Dangerous goods by Road (Europe)	LD50/LC50 - Lethal Dose/Concentration kill 50%
ASTM - American Society for Testing and Materials (	LDLo/LCLo - Lowest Published Lethal Dose/Concentration
BOD5 - Biological Oxygen Demand in 5 days	NAERG'96 - North American Emergency Response Guide Book (1996)
CAN/CGA B149.2 Propane Installation Code	NFPA - National Fire Prevention Association
CAS - Chemical Abstract Services	NIOSH - National Institute for Occupational Safety & Health
CEPA - Canadian Environmental Protection Act	NPRI - National Pollutant Release Inventory
CERCLA - Comprehensive Environmental Response, Compensation and Liability Act	NSNR - New Substances Notification Regulations (Canada)
CFR - Code of Federal Regulations	NTP - National Toxicology Program
CHIP - Chemicals Hazard Information and Packaging Approved Supply List	OSHA - Occupational Safety & Health Administration
COD5 - Chemical Oxygen Demand in 5 days	PEL - Permissible Exposure Limit
CPR - Controlled Products Regulations	RCRA - Resource Conservation and Recovery Act
DOT - Department of Transport	SARA - Superfund Amendments and Reorganization Act
DSCL - Dangerous Substances Classification and Labeling (Europe)	SD - Single Dose
DSD/DPD - Dangerous Substances or Dangerous Preparations Directives (Europe)	STEL - Short Term Exposure Limit (15 minutes)
DSL - Domestic Substance List	TDG - Transportation Dangerous Goods (Canada)
EEC/EU - European Economic Community/European Union	TDL <sub>o</sub> /TCL <sub>o</sub> - Lowest Published Toxic Dose/Concentration
EINECS - European Inventory of Existing Commercial Chemical Substances	TLm - Median Tolerance Limit
EPCRA - Emergency Planning and Community Right to Know Act	TLV-TWA - Threshold Limit Value-Time Weighted Average
FDA - Food and Drug Administration	TSCA - Toxic Substances Control Act
FIFRA - Federal Insecticide, Fungicide and Rodenticide Act	USEPA - United States Environmental Protection Agency
HCS - Hazardous Communication System	USP - United States Pharmacopoeia
HMIS - Hazardous Material Information System	WHMIS - Workplace Hazardous Material Information System
IARC - International Agency for Research on Cancer	

**Information Contact Internet: [www.petro-canada.ca](http://www.petro-canada.ca)**

**Lubricants:**  
**Western Canada, telephone: 1-800-661-1199;**  
**fax: (780) 464-9564**  
**Ontario & Central Canada, telephone:**  
**1-800-268-5850 and (905) 822-4222; fax:**  
**1-800-201-6285**  
**Quebec & Eastern Canada, telephone:**  
**1-800-576-1686; fax: 800-201-6285**

**For Product Safety Information: (905) 804-4752**

**Prepared by Product Safety - JDW on 12/18/2002.**

**Data entry by Product Safety - JDW.**

*To the best of our knowledge, the information contained herein is accurate. However, neither the above named supplier nor any of its subsidiaries assumes any liability whatsoever for the accuracy or completeness of the information contained herein. Final determination of suitability of any material is the sole responsibility of the user. All materials may present unknown hazards and should be used with caution. Although certain hazards are described herein, we cannot guarantee that these are the only hazards that exist.*



WHMIS (Pictograms)	WHMIS (Classification)	Protective Clothing	TDG (pictograms)
	<b>Not controlled</b>		

<b>Section 1. Chemical Product and Company Identification</b>	
<b>Product Name</b>	<b>TRAXON* XL SYNTHETIC BLEND 75W-90, 80W-140</b>
<b>Synonym</b>	Not available
<b>Manufacturer</b>	PETRO-CANADA P.O. Box 2844 Calgary, Alberta T2P 3E3
<b>Material Uses</b>	These products are multipurpose automotive hypoid gear lubricants, suitable for use in lower temperatures in passenger cars, trucks and off-highway vehicles.
<b>Code</b>	TRXL759, 470-499-0 TRXL814, 470-500-0
<b>Validated on</b>	5/29/2003.
<b>In case of Emergency</b>	Petro-Canada: 403-296-3000 Canutec Transportation: 613-996-6666 Poison Control Centre: Consult local telephone directory for emergency number(s).

<b>Section 2. Composition and Information on Ingredients</b>					
			<i>Exposure Limits (ACGIH)</i>		
Name	CAS #	% (W/W)	TLV-TWA(8 h)	STEL	CEILING
1) Mixture of severely hydrotreated and hydrocracked and/or solvent-refined base oil (petroleum), synthetic hydrocarbons and other proprietary, non-hazardous additives.	Mixture	100	5 mg/m <sup>3</sup> (oil mist)	10 mg/m <sup>3</sup> (oil mist)	Not established
<b>Manufacturer Recommendation</b>	Not applicable				
<b>Other Exposure Limits</b>	Consult local, state, provincial or territory authorities for acceptable exposure limits.				

<b>Section 3. Hazards Identification.</b>	
<b>Potential Health Effects</b>	Non irritating to slight transient irritation to skin and eyes, but no permanent damage. Relatively non-toxic via ingestion. This product has a low vapour pressure and is not expected to present an inhalation exposure at ambient conditions. Upon heating to high temperatures, or mechanical actions which may produce vapours or mists, inhalation of product may cause irritation of the breathing passages. For more information, refer to Section 11.

<b>Section 4. First Aid Measures</b>	
<b>Eye Contact</b>	IMMEDIATELY flush eyes with running water for at least 15 minutes, keeping eyelids open. Seek medical attention.
<b>Skin Contact</b>	Remove contaminated clothing - launder before reuse. Wash gently and thoroughly the contaminated skin with running water and non-abrasive soap. Seek medical attention.
<b>Inhalation</b>	Evacuate the victim to a safe area as soon as possible. If the victim is not breathing, perform artificial respiration. Allow the victim to rest in a well ventilated area. Seek medical attention.
<b>Ingestion</b>	DO NOT induce vomiting because of danger of aspirating liquid into lungs. Seek medical attention.
<b>Note to Physician</b>	Not available

<b>Section 5. Fire-fighting Measures</b>			
<b>Flammability</b>	May be combustible at high temperature.	<b>Flammable Limits</b>	Not available
<b>Flash Points</b>	OPEN CUP: ≥183°C (361.4°F) (Cleveland)	<b>Auto-Ignition Temperature</b>	Not available
<b>Fire Hazards in Presence of Various Substances</b>	Low fire hazard. This material must be heated before ignition will occur.	<b>Explosion Hazards in Presence of Various Substances</b>	Do not cut, weld, heat, drill or pressurize empty container. Containers may explode in heat of fire.
<b>Products of Combustion</b>	Carbon oxides (CO, CO <sub>2</sub> ), nitrogen oxides (NO <sub>x</sub> ), sulphur oxides (SO <sub>x</sub> ), smoke and irritating vapours as products of incomplete combustion.		

<b>Fire Fighting Media and Instructions</b>	NAERG96, GUIDE 171, Substances (low to moderate hazard). If tank, rail car or tank truck is involved in a fire, ISOLATE for 800 meters (0.5 mile) in all directions; also, consider initial evacuation for 800 meters (0.5 mile) in all directions. Shut off fuel to fire if it is possible to do so without hazard. If this is impossible, withdraw from area and let fire burn out under controlled conditions. Withdraw immediately in case of rising sound from venting safety device or any discolouration of tank due to fire. Cool containing vessels with water spray in order to prevent pressure build-up, autoignition or explosion. SMALL FIRE: use DRY chemicals, foam, water spray or CO2. LARGE FIRE: use water spray, fog or foam. For small outdoor fires, portable fire extinguishers may be used, and self contained breathing apparatus (SCBA) may not be required. For all indoor fires and any significant outdoor fires, SCBA is required. Respiratory and eye protection are required for fire fighting personnel.
---	--

### Section 6. Accidental Release Measures

<b>Material Release or Spill</b>	Consult current National Emergency Response Guide Book (NAERG) for appropriate spill measures if necessary. Extinguish all ignition sources. Stop leak if safe to do so. Dike spilled material. Use appropriate inert absorbent material to absorb spilled product. Collect used absorbent for later disposal. Avoid contact with spilled material. Avoid contaminating sewers, streams, rivers and other water courses with spilled material. Notify appropriate authorities immediately.
----------------------------------	--

### Section 7. Handling and Storage

<b>Handling</b>	Avoid contact with any sources of ignition, flames, heat, and sparks. Avoid skin contact. Avoid eye contact. Avoid inhalation of product vapours or mists. Empty containers may contain product residue. Do not pressurize, cut, heat, or weld empty containers. Do not reuse containers without commercial cleaning and/or reconditioning. Personnel who handle this material should practice good personal hygiene during and after handling to help prevent accidental ingestion of this product. Properly dispose of contaminated leather articles including shoes that cannot be decontaminated.
<b>Storage</b>	Store in dry, cool, well-ventilated area. Keep container tightly closed. Store away from incompatible and reactive materials (See section 5 and 10).

### Section 8. Exposure Controls/Personal Protection

<b>Engineering Controls</b>	For normal application, special ventilation is not necessary. If user's operations generate vapours or mist, use ventilation to keep exposure to airborne contaminants below the exposure limit. Make-up air should always be supplied to balance air removed by exhaust ventilation. Ensure that eyewash station and safety shower are close to work-station.
<b>Personal Protection - <i>The selection of personal protective equipment varies, depending upon conditions of use.</i></b>	
<b>Eyes</b>	Eye protection (i.e., safety glasses, safety goggles and/or face shield) should be determined based on conditions of use. If product is used in an application where splashing may occur, the use of safety goggles and/or a face shield should be considered.
<b>Body</b>	Wear appropriate clothing to prevent skin contact. As a minimum long sleeves and trousers should be worn.
<b>Respiratory</b>	Where concentrations in air may exceed the occupational exposure limits given in Section 2 (and those applicable to your area) and where engineering, work practices or other means of exposure reduction are not adequate, NIOSH approved respirators may be necessary to prevent overexposure by inhalation.
<b>Hands</b>	Wear appropriate chemically protective gloves. When handling hot product ensure gloves are heat resistant and insulated.
<b>Feet</b>	Wear appropriate footwear to prevent product from coming in contact with feet and skin.

### Section 9. Physical and Chemical Properties

<b>Physical State and Appearance</b>	Viscous liquid.	<b>Viscosity</b>	75W90: 106.7 cSt @ 40°C (104°F), 16.52 cSt @ 100°C (212°F), VI=168 80W140: 254.8 cSt @ 40°C (104°F), 25.24 cSt @ 100°C (212°F), VI=127
<b>Colour</b>	Colourless to pale yellow.	<b>Pour Point</b>	75W90: -42°C (-44°F) 80W140: -36°C (-33°F)
<b>Odour</b>	No odour or slight petroleum oil like.	<b>Softening Point</b>	Not applicable.
<b>Odour Threshold</b>	Not available	<b>Dropping Point</b>	Not applicable.
<b>Boiling Point</b>	Not available	<b>Penetration</b>	Not applicable.
<b>Density</b>	0.8699 - 0.878 kg/L @ 15°C (59°F).	<b>Oil / Water Dist. Coefficient</b>	Not available
<b>Vapour Density</b>	Not available	<b>Ionicity (in water)</b>	Not available
<b>Vapour Pressure</b>	Negligible at ambient temperature and pressure.	<b>Dispersion Properties</b>	Not available
<b>Volatility</b>	Non-volatile	<b>Solubility</b>	Insoluble in water.

**Section 10. Stability and Reactivity**

<b>Corrosivity</b>	Copper corrosion, 3h, 121°C (ASTM D0130): 1b		
<b>Stability</b>	The product is stable under normal handling and storage conditions.	<b>Hazardous Polymerization</b>	Will not occur under normal working conditions.
<b>Incompatible Substances / Conditions to Avoid</b>	Reactive with oxidizing agents.	<b>Decomposition Products</b>	May release CO <sub>x</sub> , NO <sub>x</sub> , SO <sub>x</sub> , H <sub>2</sub> S, PO <sub>x</sub> , SiO <sub>x</sub> , methacrylate monomers, aldehydes, alkyl mercaptans, smoke and irritating vapours when heated to decomposition.

**Section 11. Toxicological Information**

<b>Routes of Entry</b>	Skin contact, eye contact, inhalation and ingestion.		
<b>Acute Lethality</b>	Based on toxicity of components. Acute oral toxicity (LD50): >5000 mg/kg (rat). Acute dermal toxicity (LD50): >2000 mg/kg (rabbit). Acute inhalation toxicity (LC50): >2500 mg/m <sup>3</sup> /4h (rat).		
<b>Chronic or Other Toxic Effects</b>	<p>Dermal Route: Prolonged or repeated contact may cause skin irritation characterized by dermatitis or oil acne.</p> <p>Inhalation Route: Negligible breathing hazard at normal temperatures (up to 38°C) or recommended blending temperatures. Elevated temperatures or mechanical action may form vapours, mists or fumes. Inhalation of oil mists or vapours from hot oil may cause irritation of the upper respiratory tract.</p> <p>Oral Route: Low toxicity; has laxative effect.</p> <p>Eye Irritation/Inflammation: Repeated or prolonged contact may cause transient irritation, but no permanent damage.</p> <p>Immunotoxicity: Not available</p> <p>Skin Sensitization: This product is not expected to be a skin sensitizer, based on the available data and the known hazards of the components.</p> <p>Respiratory Tract Sensitization: This product is not expected to be a respiratory tract sensitizer, based on the available data and the known hazards of the components.</p> <p>Mutagenic: This product is not expected to be a mutagen, based on the available data and the known hazards of the components.</p> <p>Reproductive Toxicity: This product is not expected to be a reproductive hazard, based on the available data and the known hazards of the components.</p> <p>Teratogenicity/Embryotoxicity: This product is not expected to be a teratogen or an embryotoxin, based on the available data and the known hazards of the components.</p> <p>Carcinogenicity (ACGIH): This product is not known to contain any chemicals at reportable quantities that are listed as A1 or A2 carcinogens by ACGIH.</p> <p>Carcinogenicity (IARC): This product is not known to contain any chemicals at reportable quantities that are listed as group 1, 2A or 2B carcinogens by IARC.</p> <p>Carcinogenicity (NTP): This product is not known to contain any chemicals at reportable quantities that are listed as carcinogens by NTP.</p> <p>Carcinogenicity (IRIS): This product is not known to contain any chemicals at reportable quantities that are listed as carcinogens by IRIS.</p> <p>Carcinogenicity (OSHA): This product is not known to contain any chemicals at reportable quantities that are listed as carcinogens by OSHA.</p>		
<b>Other Considerations</b>	No additional remark.		

**Section 12. Ecological Information**

<b>Environmental Fate</b>	Not available	<b>Persistence/ Bioaccumulation Potential</b>	Not available
<b>BOD5 and COD</b>	Not available	<b>Products of Biodegradation</b>	Not available
<b>Additional Remarks</b>	No additional remark.		





**Section 13. Disposal Considerations**

<b>Waste Disposal</b>	Spent/ used/ waste product may meet the requirements of a hazardous waste. Consult your local or regional authorities. Ensure that waste management processes are in compliance with government requirements and local disposal regulations.		
-----------------------	--	--	--

**Section 14. Transport Information**

<b>TDG Classification</b>	Not controlled under TDG (Canada).	<b>Special Provisions for Transport</b>	Not applicable.
---------------------------	------------------------------------	---	-----------------

**Section 15. Regulatory Information**

<b>Other Regulations</b>		<p>This product is acceptable for use under the provisions of WHMIS-CPR. All components of this formulation are listed on the CEPA-DSL (Domestic Substances List).</p> <p>All components of this formulation are listed on the US EPA-TSCA Inventory.</p> <p>All components of this product are on the European Inventory of Existing Commercial Chemical Substances (EINECS).</p> <p>This product has been classified in accordance with the hazard criteria of the Controlled Products Regulations (CPR) and the MSDS contains all of the information required by the CPR.</p> <p>Please contact Product Safety for more information.</p>																								
<b>DSD/DPD (Europe)</b>	Not classified under the Dangerous Substances or Dangerous Preparations Directives.	<b>HCS (U.S.A.)</b>	Not controlled under the HCS (United States).																							
<b>ADR (Europe) (Pictograms)</b>	<p>NOT EVALUATED FOR EUROPEAN TRANSPORT</p> <p>NON ÉVALUÉ POUR LE TRANSPORT EUROPÉEN.</p>	<b>DOT (U.S.A) (Pictograms)</b>																								
<b>HMS (U.S.A.)</b>	<table border="1"> <tr> <td>Health Hazard</td> <td>1</td> </tr> <tr> <td>Fire Hazard</td> <td>1</td> </tr> <tr> <td>Reactivity</td> <td>0</td> </tr> <tr> <td>Personal Protection</td> <td>B</td> </tr> </table>	Health Hazard	1	Fire Hazard	1	Reactivity	0	Personal Protection	B	<b>NFPA (U.S.A.)</b>	<table border="1"> <tr> <td></td> <td><b>Rating</b></td> <td>0 Insignificant</td> </tr> <tr> <td></td> <td></td> <td>1 Slight</td> </tr> <tr> <td></td> <td></td> <td>2 Moderate</td> </tr> <tr> <td></td> <td></td> <td>3 High</td> </tr> <tr> <td></td> <td></td> <td>4 Extreme</td> </tr> </table>		<b>Rating</b>	0 Insignificant			1 Slight			2 Moderate			3 High			4 Extreme
Health Hazard	1																									
Fire Hazard	1																									
Reactivity	0																									
Personal Protection	B																									
	<b>Rating</b>	0 Insignificant																								
		1 Slight																								
		2 Moderate																								
		3 High																								
		4 Extreme																								

**Section 16. Other Information**

<b>References</b>	<p>Available upon request.</p> <p>* Marque de commerce de Petro-Canada - Trademark</p>
-------------------	--

<b>Glossary</b>	
<p>ACGIH - American Conference of Governmental Industrial Hygienists</p> <p>ADR - Agreement on Dangerous goods by Road (Europe)</p> <p>ASTM - American Society for Testing and Materials (</p> <p>BOD5 - Biological Oxygen Demand in 5 days</p> <p>CAN/CGA B149.2 Propane Installation Code</p> <p>CAS - Chemical Abstract Services</p> <p>CEPA - Canadian Environmental Protection Act</p> <p>CERCLA - Comprehensive Environmental Response, Compensation and Liability Act</p> <p>CFR - Code of Federal Regulations</p> <p>CHIP - Chemicals Hazard Information and Packaging Approved Supply List</p> <p>COD5 - Chemical Oxygen Demand in 5 days</p> <p>CPR - Controlled Products Regulations</p> <p>DOT - Department of Transport</p> <p>DSCL - Dangerous Substances Classification and Labeling (Europe)</p> <p>DSD/DPD - Dangerous Substances or Dangerous Preparations Directives (Europe)</p> <p>DSL - Domestic Substance List</p> <p>EEC/EU - European Economic Community/European Union</p> <p>EINECS - European Inventory of Existing Commercial Chemical Substances</p> <p>EPCRA - Emergency Planning and Community Right to Know Act</p> <p>FDA - Food and Drug Administration</p> <p>FIFRA - Federal Insecticide, Fungicide and Rodenticide Act</p> <p>HCS - Hazardous Communication System</p> <p>HMS - Hazardous Material Information System</p> <p>IARC - International Agency for Research on Cancer</p>	<p>IRIS - Integrated Risk Information System</p> <p>LD50/LC50 - Lethal Dose/Concentration kill 50%</p> <p>LDLo/LCLo - Lowest Published Lethal Dose/Concentration</p> <p>NAERG'96 - North American Emergency Response Guide Book (1996)</p> <p>NFPA - National Fire Prevention Association</p> <p>NIOSH - National Institute for Occupational Safety &amp; Health</p> <p>NPRI - National Pollutant Release Inventory</p> <p>NSNR - New Substances Notification Regulations (Canada)</p> <p>NTP - National Toxicology Program</p> <p>OSHA - Occupational Safety &amp; Health Administration</p> <p>PEL - Permissible Exposure Limit</p> <p>RCRA - Resource Conservation and Recovery Act</p> <p>SARA - Superfund Amendments and Reorganization Act</p> <p>SD - Single Dose</p> <p>STEL - Short Term Exposure Limit (15 minutes)</p> <p>TDG - Transportation Dangerous Goods (Canada)</p> <p>TDL0/TCLo - Lowest Published Toxic Dose/Concentration</p> <p>TLm - Median Tolerance Limit</p> <p>TLV-TWA - Threshold Limit Value-Time Weighted Average</p> <p>TSCA - Toxic Substances Control Act</p> <p>USEPA - United States Environmental Protection Agency</p> <p>USP - United States Pharmacopoeia</p> <p>WHMIS - Workplace Hazardous Material Information System</p>

<b>For Copy of MSDS</b>	<b>Prepared by Product Safety - JDW on 5/29/2003.</b>
<p>The Canadian Controlled Products Regulations (CPR) (Under the Hazardous Products Act, part of the WHMIS legislation) only apply to WHMIS Controlled (i.e., hazardous) products. Therefore, the CPR and the 3-year update rule specified therein do not apply to WHMIS Non-Controlled products. Although this is true, customarily Petro-Canada reviews and updates Non-Controlled product MSDS if a customer requests such an update. These Non-Controlled product updates are given a lower priority than Controlled products but are handled as soon as practicable. If you would like to verify if the MSDS you have is the most current, or you require any further information, please contact:</p> <p>Internet: <a href="http://www.petro-canada.ca">www.petro-canada.ca</a></p> <p>Lubricants: Western Canada, telephone: 1-800-661-1199; fax: (780) 464-9564</p>	<b>Data entry by Product Safety - JDW.</b>

Ontario & Central Canada, telephone: 1-800-268-5850 and (905) 822-4222; fax:  
1-800-201-6285  
Quebec & Eastern Canada, telephone: 1-800-576-1686; fax: 800-201-6285

For Product Safety Information: (905) 804-4752

*To the best of our knowledge, the information contained herein is accurate. However, neither the above named supplier nor any of its subsidiaries assumes any liability whatsoever for the accuracy or completeness of the information contained herein. Final determination of suitability of any material is the sole responsibility of the user. All materials may present unknown hazards and should be used with caution. Although certain hazards are described herein, we cannot guarantee that these are the only hazards that exist.*



**MATERIAL SAFETY DATA SHEET**

---

Date Prepared: April 06, 2002  
Supersedes: January 08, 1999  
MSDS Number: 08258

---

**1. PRODUCT INFORMATION**

Product Identifier: UNIVIS N 22

Application and Use:  
Hydraulic fluid

Product Description:

Mixture of paraffinic and naphthenic hydrocarbons (saturated and unsaturated), and additives.

---

REGULATORY CLASSIFICATION

WHMIS:  
Not a controlled product

CEPA: CANADIAN ENVIRONMENTAL PROTECTION ACT  
All components of this product are either on the Domestic Substances List (DSL) or are exempt.

TDG INFORMATION (RAIL/ROAD):  
Not Regulated in Canada.

Please be aware that other regulations may apply.

---

TELEPHONE NUMBERS

Emergency 24 hr. (519) 339-2145  
Technical Info. (800) 268-3183

MANUFACTURER/SUPPLIER:

IMPERIAL OIL  
Products Division  
111 St Clair Avenue West  
Toronto, Ontario  
M5W 1K3  
(416) 968-4441

## 2. REGULATED COMPONENTS

The following components are defined in accordance with sub-paragraph 13(a) (i) to (iv) or paragraph 14(a) of the Hazardous Products Act:

NAME	%	CAS #
Not applicable		

## 3. TYPICAL PHYSICAL & CHEMICAL PROPERTIES

Physical State: Liquid  
 Specific gravity: not available  
 Viscosity: 22.00 cSt at 40 deg C  
 Vapour Density: not available  
 Boiling Point: 229 to 512 deg C  
 Evaporation rate: <0.1 (1= n-butylacetate)  
 Solubility in water: negligible  
 Freezing/Pour Point: -48 deg C ASTM D97  
 Odour Threshold: not available  
 Vapour Pressure: <1 kPa at 38 deg C  
 Density: 0.87 g/cc at 15 deg C  
 Appearance/odour: Yellow oil, petroleum odour

## 4. HEALTH HAZARD INFORMATION

### NATURE OF HAZARD

#### INHALATION:

Negligible hazard at normal temperatures (up to 38 deg C).  
 Elevated temperatures or mechanical action may form vapours, mists or fumes which may be irritating to the eyes, nose, throat and lungs.  
 Avoid breathing vapours or mists.

#### EYE CONTACT:

Slightly irritating, but will not injure eye tissue.

#### SKIN CONTACT:

Low toxicity.  
 Frequent or prolonged contact may irritate the skin.

#### INGESTION:

Low toxicity.

#### ACUTE TOXICITY DATA:

Based on animal testing data from similar materials and products, the acute toxicity of this product is expected to be:

Oral : LD50 > 5000 mg/kg (Rat)  
Dermal : LD50 > 3160 mg/kg (Rabbit)  
Inhalation : LC50 > 5000 mg/m3 (Rat)

**OCCUPATIONAL EXPOSURE LIMIT:**

**ACGIH recommends:**

For oil mists, 5 mg/m3.

Local regulated limits may vary.

---

## 5. FIRST AID MEASURES

**INHALATION:**

Vapour pressure of this material is low and as such inhalation under normal conditions is usually not a problem. If overexposed to oil mist, remove from further exposure. Administer artificial respiration if breathing has stopped. Keep at rest. Call for prompt medical attention.

**EYE CONTACT:**

Flush eyes with large amounts of water until irritation subsides. If irritation persists, get medical attention.

**SKIN CONTACT:**

Flush with large amounts of water. Use soap if available. Remove severely contaminated clothing (including shoes) and launder before reuse. If irritation persists, seek medical attention.

**INGESTION:**

If swallowed, DO NOT induce vomiting. Keep at rest. Get prompt medical attention.

---

## 6. PREVENTIVE AND CORRECTIVE MEASURES

**PERSONAL PROTECTION:**

The selection of personal protective equipment varies, depending upon conditions of use.

In open systems where contact is likely, wear safety goggles, chemical-resistant overalls, and chemically impervious gloves.

Where only incidental contact is likely, wear safety glasses with side shields. No other special precautions are necessary provided skin/eye contact is avoided.

Where concentrations in air may exceed the occupational exposure limits given in Section 4 and where engineering, work practices or other means of exposure reduction are not adequate, approved respirators may be necessary to prevent overexposure by inhalation.

**ENGINEERING CONTROLS:**

The use of local exhaust ventilation is recommended to control emissions near the source. Laboratory samples should be handled in a fumehood. Provide mechanical ventilation of confined spaces.

**HANDLING, STORAGE AND SHIPPING:**

Keep containers closed. Handle and open containers with care. Store in a cool, well ventilated place away from incompatible materials. Do not handle or store near an open flame, sources of heat, or sources of ignition. In keeping with good personal hygiene practices, wash hands thoroughly after handling the material. Empty containers may contain product residue. Do not pressurize cut, heat, or weld empty containers. Do not reuse empty containers without commercial cleaning or reconditioning.

**LAND SPILL:**

Eliminate source of ignition. Keep public away. Prevent additional discharge of material, if possible to do so without hazard. Prevent spills from entering sewers, watercourses or low areas. Contain spilled liquid with sand or earth. Recover by pumping or by using a suitable absorbant. Consult an expert on disposal of recovered material. Ensure disposal in compliance with government requirements and ensure conformity to local disposal regulations. Notify the appropriate authorities immediately. Take all additional action necessary to prevent and remedy the adverse effects of the spill.

**WATER SPILL:**

Remove from surface by skimming or with suitable absorbents. If allowed by local authorities and environmental agencies, sinking and/or suitable dispersants may be used in unconfined waters. Consult an expert on disposal of recovered material. Ensure disposal in compliance with government requirements and ensure conformity to local disposal regulations. Notify the appropriate authorities immediately. Take all additional action necessary to prevent and remedy the adverse effects of the spill.

---

**7. FIRE AND EXPLOSION HAZARD**

Flashpoint and method: 150 deg C COC ASTM D92

Autoignition: NA Flammable Limits: LEL: NA UEL: NA

**GENERAL HAZARDS:**

Low Hazard; liquids may burn upon heating to temperatures at or above the flash point.  
Toxic gases will form upon combustion.

**FIRE FIGHTING:**

Use water spray to cool fire exposed surfaces and to protect personnel.  
Shut off fuel to fire.  
Use foam, dry chemical or water spray to extinguish fire.  
Respiratory and eye protection required for fire fighting personnel.  
Avoid spraying water directly into storage containers due to danger of boilover.  
A self-contained breathing apparatus (SCBA) should be used for all indoor fires and any significant outdoor fires. For small outdoor fires, which may easily be extinguished with a portable fire extinguisher, use of an SCBA may not be required.

**HAZARDOUS COMBUSTION PRODUCTS:**

Smoke, carbon monoxide, carbon dioxide under thermal decomposition.

---

**8. REACTIVITY DATA**

**STABILITY:**

This product is stable. Hazardous polymerization will not occur.

**INCOMPATIBLE MATERIALS AND CONDITIONS TO AVOID:**

Strong oxidizing agents

**HAZARDOUS DECOMPOSITION:**

none

---

**9. NOTES**

All components of this product are listed on the U.S. TSCA inventory.

THREE YEAR WHMIS REVIEW.

---

**10. PREPARATION**

Date Prepared: April 06, 2002  
Prepared by: Lubricants & Specialties  
IMPERIAL OIL  
Products Division

111 St Clair Avenue West  
Toronto, Ontario  
M5W 1K3  
(800) 268-3183

---

CAUTION: " The information contained herein relates only to this product or material and may not be valid when used in combination with any other product or material or in any process. If the product is not to be used for a purpose or under conditions which are normal or reasonably foreseeable, this information cannot be relied upon as complete or applicable. For greater certainty, uses other than those described in Section 1 must be reviewed with the supplier. The information contained herein is based on the information available at the indicated date of preparation. This MSDS is for the use of Imperial Oil customers and their employees and agents only. Any further distribution of this MSDS by Imperial Oil customers is prohibited without the written consent of Imperial Oil."



**MATERIAL SAFETY DATA SHEET**

---

Date Prepared: April 06, 2002  
Supersedes: January 08, 1999  
MSDS Number: 08259

---

**1. PRODUCT INFORMATION**

Product Identifier: UNIVIS N 32

Application and Use:  
Hydraulic fluid

Product Description:

Mixture of paraffinic and naphthenic hydrocarbons (saturated and unsaturated), and additives.

---

REGULATORY CLASSIFICATION

WHMIS:  
Not a controlled product

CEPA: CANADIAN ENVIRONMENTAL PROTECTION ACT  
All components of this product are either on the Domestic Substances List (DSL) or are exempt.

TDG INFORMATION (RAIL/ROAD):  
Not Regulated in Canada.

Please be aware that other regulations may apply.

---

TELEPHONE NUMBERS

Emergency 24 hr. (519) 339-2145  
Technical Info. (800) 268-3183

MANUFACTURER/SUPPLIER:

IMPERIAL OIL  
Products Division  
111 St Clair Avenue West  
Toronto, Ontario  
M5W 1K3  
(416) 968-4441

## 2. REGULATED COMPONENTS

The following components are defined in accordance with sub-paragraph 13(a) (i) to (iv) or paragraph 14(a) of the Hazardous Products Act:

NAME	%	CAS #
Not applicable		

## 3. TYPICAL PHYSICAL & CHEMICAL PROPERTIES

Physical State: Liquid  
 Specific gravity: not available  
 Viscosity: 32.00 cSt at 40 deg C  
 Vapour Density: not available  
 Boiling Point: 229 to 512 deg C  
 Evaporation rate: <0.1 (1= n-butylacetate)  
 Solubility in water: negligible  
 Freezing/Pour Point: -42 deg C ASTM D97  
 Odour Threshold: not available  
 Vapour Pressure: <1 kPa at 38 deg C  
 Density: 0.87 g/cc at 15 deg C  
 Appearance/odour: Yellow oil, petroleum odour

## 4. HEALTH HAZARD INFORMATION

### NATURE OF HAZARD

#### INHALATION:

Negligible hazard at normal temperatures (up to 38 deg C).  
 Elevated temperatures or mechanical action may form vapours, mists or fumes which may be irritating to the eyes, nose, throat and lungs.  
 Avoid breathing vapours or mists.

#### EYE CONTACT:

Slightly irritating, but will not injure eye tissue.

#### SKIN CONTACT:

Low toxicity.  
 Frequent or prolonged contact may irritate the skin.

#### INGESTION:

Low toxicity.

#### ACUTE TOXICITY DATA:

Based on animal testing data from similar materials and products, the acute toxicity of this product is expected to be:

Oral : LD50 > 5000 mg/kg (Rat)  
Dermal : LD50 > 3160 mg/kg (Rabbit)  
Inhalation : LC50 > 5000 mg/m3 (Rat)

**OCCUPATIONAL EXPOSURE LIMIT:**

**ACGIH recommends:**

For oil mists, 5 mg/m3.

Local regulated limits may vary.

---

## 5. FIRST AID MEASURES

**INHALATION:**

Vapour pressure of this material is low and as such inhalation under normal conditions is usually not a problem. If overexposed to oil mist, remove from further exposure. Administer artificial respiration if breathing has stopped. Keep at rest. Call for prompt medical attention.

**EYE CONTACT:**

Flush eyes with large amounts of water until irritation subsides. If irritation persists, get medical attention.

**SKIN CONTACT:**

Flush with large amounts of water. Use soap if available. Remove severely contaminated clothing (including shoes) and launder before reuse. If irritation persists, seek medical attention.

**INGESTION:**

If swallowed, DO NOT induce vomiting. Keep at rest. Get prompt medical attention.

---

## 6. PREVENTIVE AND CORRECTIVE MEASURES

**PERSONAL PROTECTION:**

The selection of personal protective equipment varies, depending upon conditions of use. In open systems where contact is likely, wear safety goggles, chemical-resistant overalls, and chemically impervious gloves. Where only incidental contact is likely, wear safety glasses with side shields. No other special precautions are necessary provided skin/eye contact is avoided.

Where concentrations in air may exceed the occupational exposure limits given in Section 4 and where engineering, work practices or other means of exposure reduction are not adequate, approved respirators may be necessary to prevent overexposure by inhalation.

**ENGINEERING CONTROLS:**

The use of local exhaust ventilation is recommended to control emissions near the source. Laboratory samples should be handled in a fumehood. Provide mechanical ventilation of confined spaces.

**HANDLING, STORAGE AND SHIPPING:**

Keep containers closed. Handle and open containers with care. Store in a cool, well ventilated place away from incompatible materials. In keeping with good personal hygiene practices, wash hands thoroughly after handling the material. Empty containers may contain product residue. Do not pressurize cut, heat, or weld empty containers. Do not reuse empty containers without commercial cleaning or reconditioning.

**LAND SPILL:**

Eliminate source of ignition. Keep public away. Prevent additional discharge of material, if possible to do so without hazard. Prevent spills from entering sewers, watercourses or low areas. Contain spilled liquid with sand or earth. Recover by pumping or by using a suitable absorbant. Consult an expert on disposal of recovered material. Ensure disposal in compliance with government requirements and ensure conformity to local disposal regulations. Notify the appropriate authorities immediately. Take all additional action necessary to prevent and remedy the adverse effects of the spill.

**WATER SPILL:**

Remove from surface by skimming or with suitable absorbents. If allowed by local authorities and environmental agencies, sinking and/or suitable dispersants may be used in unconfined waters. Consult an expert on disposal of recovered material. Ensure disposal in compliance with government requirements and ensure conformity to local disposal regulations. Notify the appropriate authorities immediately. Take all additional action necessary to prevent and remedy the adverse effects of the spill.

---

**7. FIRE AND EXPLOSION HAZARD**

Flashpoint and method: 165 deg C COC ASTM D92

Autoignition: NA Flammable Limits: LEL: NA UEL: NA

**GENERAL HAZARDS:**

Low Hazard; liquids may burn upon heating to temperatures at or above the flash point.  
Toxic gases will form upon combustion.

**FIRE FIGHTING:**

Use water spray to cool fire exposed surfaces and to protect personnel. Shut off fuel to fire.

Use foam, dry chemical or water spray to extinguish fire. Respiratory and eye protection required for fire fighting personnel. Avoid spraying water directly into storage containers due to danger of boilover.

A self-contained breathing apparatus (SCBA) should be used for all indoor fires and any significant outdoor fires. For small outdoor fires, which may easily be extinguished with a portable fire extinguisher, use of an SCBA may not be required.

**HAZARDOUS COMBUSTION PRODUCTS:**

Smoke, carbon monoxide, carbon dioxide and traces of oxides of sulphur

---

## 8. REACTIVITY DATA

**STABILITY:**

This product is stable. Hazardous polymerization will not occur.

**INCOMPATIBLE MATERIALS AND CONDITIONS TO AVOID:**

Strong oxidizing agents

**HAZARDOUS DECOMPOSITION:**

none

---

## 9. NOTES

All components of this product are listed on the U.S. TSCA inventory.

THREE YEAR WHMIS REVIEW.

---

## 10. PREPARATION

Date Prepared: April 06, 2002  
Prepared by: Lubricants & Specialties  
IMPERIAL OIL  
Products Division  
111 St Clair Avenue West  
Toronto, Ontario

M5W 1K3  
(800) 268-3183

---

CAUTION: " The information contained herein relates only to this product or material and may not be valid when used in combination with any other product or material or in any process. If the product is not to be used for a purpose or under conditions which are normal or reasonably foreseeable, this information cannot be relied upon as complete or applicable. For greater certainty, uses other than those described in Section 1 must be reviewed with the supplier. The information contained herein is based on the information available at the indicated date of preparation. This MSDS is for the use of Imperial Oil customers and their employees and agents only. Any further distribution of this MSDS by Imperial Oil customers is prohibited without the written consent of Imperial Oil."

**MATERIAL SAFETY DATA SHEET**

---

Date Prepared: May 13, 2003  
Supersedes: April 12, 2000  
MSDS Number: 08265

---

**1. PRODUCT INFORMATION**

Product Identifier: UNIVIS N 68

Application and Use:  
Hydraulic fluid

Product Description:

A lubricating oil consisting of a mixture of saturated and unsaturated hydrocarbons derived from paraffinic distillate, and additives.

---

**REGULATORY CLASSIFICATION**

WHMIS:  
Not a controlled product

CEPA: CANADIAN ENVIRONMENTAL PROTECTION ACT  
All components of this product are either on the Domestic Substances List (DSL) or are exempt.

TDG INFORMATION (RAIL/ROAD):  
Not Regulated in Canada.

Please be aware that other regulations may apply.

---

**TELEPHONE NUMBERS**

Emergency 24 hr. (519) 339-2145  
Technical Info. (800) 268-3183

**MANUFACTURER/SUPPLIER:**

IMPERIAL OIL  
Products Division  
111 St Clair Avenue West  
Toronto, Ontario  
M5W 1K3  
(416) 968-4441

---

## 2. REGULATED COMPONENTS

The following components are defined in accordance with sub-paragraph 13(a) (i) to (iv) or paragraph 14(a) of the Hazardous Products Act:

NAME	%	CAS #
Not applicable		

---

## 3. TYPICAL PHYSICAL & CHEMICAL PROPERTIES

Physical State: Liquid  
 Specific gravity: not available  
 Viscosity: 68.00 cSt at 40 deg C  
 Vapour Density: not available  
 Boiling Point: not available  
 Evaporation rate: <0.1 (1= n-butylacetate)  
 Solubility in water: negligible  
 Freezing/Pour Point: -36 deg C ASTM D97  
 Odour Threshold: not available  
 Vapour Pressure: <0.1 kPa at 20 deg C  
 Density: 0.88 g/cc at 15 deg C  
 Appearance/odour: Yellow oil, petroleum odour

---

## 4. HEALTH HAZARD INFORMATION

### NATURE OF HAZARD

#### INHALATION:

Negligible hazard at normal temperatures (up to 38 deg C).  
 Elevated temperatures or mechanical action may form vapours, mists or fumes which may be irritating to the eyes, nose, throat and lungs.  
 Avoid breathing vapours or mists.

#### EYE CONTACT:

Slightly irritating, but will not injure eye tissue.

#### SKIN CONTACT:

Low toxicity.  
 Frequent or prolonged contact may irritate the skin.

#### INGESTION:

Low toxicity.

#### ACUTE TOXICITY DATA:

Based on animal testing data from similar materials and products,

the acute toxicity of this product is expected to be:

Oral : LD50 > 5000 mg/kg (Rat)  
Dermal : LD50 > 3160 mg/kg (Rabbit)  
Inhalation : LC50 > 5000 mg/m3 (Rat)

**OCCUPATIONAL EXPOSURE LIMIT:**

**ACGIH recommends:**

For oil mists, 5 mg/m3.

Local regulated limits may vary.

---

## 5. FIRST AID MEASURES

**INHALATION:**

Vapour pressure of this material is low and as such inhalation under normal conditions is usually not a problem. If overexposed to oil mist, remove from further exposure. Administer artificial respiration if breathing has stopped. Keep at rest. Call for prompt medical attention.

**EYE CONTACT:**

Flush eyes with large amounts of water until irritation subsides. If irritation persists, get medical attention.

**SKIN CONTACT:**

Flush with large amounts of water. Use soap if available. Remove severely contaminated clothing (including shoes) and launder before reuse. If irritation persists, seek medical attention.

**INGESTION:**

If swallowed, DO NOT induce vomiting. Keep at rest. Get prompt medical attention.

---

## 6. PREVENTIVE AND CORRECTIVE MEASURES

**PERSONAL PROTECTION:**

The selection of personal protective equipment varies, depending upon conditions of use.

In open systems where contact is likely, wear safety goggles, chemical-resistant overalls, and chemically impervious gloves.

Where only incidental contact is likely, wear safety glasses with side shields. No other special precautions are necessary provided skin/eye contact is avoided.

Where concentrations in air may exceed the occupational exposure limits

given in Section 4 and where engineering, work practices or other means of exposure reduction are not adequate, approved respirators may be necessary to prevent overexposure by inhalation.

**ENGINEERING CONTROLS:**

The use of local exhaust ventilation is recommended to control emissions near the source. Laboratory samples should be handled in a fumehood. Provide mechanical ventilation of confined spaces.

**HANDLING, STORAGE AND SHIPPING:**

Keep containers closed. Handle and open containers with care. Store in a cool, well ventilated place away from incompatible materials. In keeping with good personal hygiene practices, wash hands thoroughly after handling the material. Store and load at normal (up to 38 deg C) temperature and at atmospheric pressure. Empty containers may contain product residue. Do not pressurize cut, heat, or weld empty containers. Do not reuse empty containers without commercial cleaning or reconditioning.

**LAND SPILL:**

Eliminate source of ignition. Keep public away. Prevent additional discharge of material, if possible to do so without hazard. Prevent spills from entering sewers, watercourses or low areas. Contain spilled liquid with sand or earth. Recover by pumping or by using a suitable absorbant. Consult an expert on disposal of recovered material. Ensure disposal in compliance with government requirements and ensure conformity to local disposal regulations. Notify the appropriate authorities immediately. Take all additional action necessary to prevent and remedy the adverse effects of the spill.

**WATER SPILL:**

Remove from surface by skimming or with suitable absorbents. If allowed by local authorities and environmental agencies, sinking and/or suitable dispersants may be used in unconfined waters. Consult an expert on disposal of recovered material. Ensure disposal in compliance with government requirements and ensure conformity to local disposal regulations. Notify the appropriate authorities immediately. Take all additional action necessary to prevent and remedy the adverse effects of the spill.

---

**7. FIRE AND EXPLOSION HAZARD**

Flashpoint and method: 190 deg C COC ASTM D92

Autoignition: NA Flammable Limits: LEL: NA UEL: NA

**GENERAL HAZARDS:**

Low Hazard; liquids may burn upon heating to temperatures at or above the flash point.  
Toxic gases will form upon combustion.

**FIRE FIGHTING:**

Use water spray to cool fire exposed surfaces and to protect personnel.  
Shut off fuel to fire.  
Use foam, dry chemical or water spray to extinguish fire.  
Respiratory and eye protection required for fire fighting personnel.  
A self-contained breathing apparatus (SCBA) should be used for all indoor fires and any significant outdoor fires. For small outdoor fires, which may easily be extinguished with a portable fire extinguisher, use of an SCBA may not be required.

**HAZARDOUS COMBUSTION PRODUCTS:**

Smoke, carbon monoxide, carbon dioxide and traces of oxides of sulphur

---

**8. REACTIVITY DATA**

**STABILITY:**

This product is stable. Hazardous polymerization will not occur.

**INCOMPATIBLE MATERIALS AND CONDITIONS TO AVOID:**

Strong oxidizing agents

**HAZARDOUS DECOMPOSITION:**

none

---

**9. NOTES**

All components of this product are listed on the U.S. TSCA inventory.

.

**REVISION SUMMARY:**

Since 12 April 2000, this MSDS has been revised in Section(s):  
3, 7

---

**10. PREPARATION**

Date Prepared: May 13, 2003  
Prepared by: Lubricants & Specialties  
IMPERIAL OIL

---

Products Division  
111 St Clair Avenue West  
Toronto, Ontario  
M5W 1K3  
(800) 268-3183

---

CAUTION: " The information contained herein relates only to this product or material and may not be valid when used in combination with any other product or material or in any process. If the product is not to be used for a purpose or under conditions which are normal or reasonably foreseeable, this information cannot be relied upon as complete or applicable. For greater certainty, uses other than those described in Section 1 must be reviewed with the supplier. The information contained herein is based on the information available at the indicated date of preparation. This MSDS is for the use of Imperial Oil customers and their employees and agents only. Any further distribution of this MSDS by Imperial Oil customers is prohibited without the written consent of Imperial Oil."



## MATERIAL SAFETY DATA SHEET

Date Prepared: November 14, 2003  
 Supersedes: September 17, 1998  
 MSDS Number: 08366

### 1. PRODUCT INFORMATION

Product Identifier: UNIREX LOTEMP MOLY GREASE

Application and Use:  
 Lubricating grease

Product Description:

A grease, a mixture of lubricating oil, soap and additives.

#### REGULATORY CLASSIFICATION

WHMIS:  
 Not a controlled product

CEPA: CANADIAN ENVIRONMENTAL PROTECTION ACT  
 All components of this product are either on the Domestic Substances List (DSL), exempt, or have been notified under CEPA.

TDG INFORMATION (RAIL/ROAD):  
 Not Regulated in Canada.

Please be aware that other regulations may apply.

#### TELEPHONE NUMBERS

Emergency 24 hr. (519) 339-2145  
 Technical Info. (800) 268-3183

#### MANUFACTURER/SUPPLIER:

IMPERIAL OIL  
 Products Division  
 111 St Clair Avenue West  
 Toronto, Ontario  
 M5W 1K3  
 (416) 968-4441

### 2. REGULATED COMPONENTS

The following components are defined in accordance with sub-paragraph 13(a) (i) to (iv) or paragraph 14(a) of the Hazardous Products Act:

NAME	%	CAS #
Not applicable		

### 3. TYPICAL PHYSICAL & CHEMICAL PROPERTIES

Physical State: Liquid  
 Specific gravity: not available  
 Viscosity: <20.00 cSt at 40 deg C  
 Vapour Density: not available  
 Boiling Point: not available  
 Evaporation rate: <1 (1= n-butylacetate)  
 Solubility in water: negligible  
 Freezing/Pour Point: 245 deg C ASTM D97  
 Odour Threshold: not available  
 Vapour Pressure: 0.002 kPa at 20 deg C  
 Density: 0.92 g/cc at 15 deg C  
 Appearance/odour: Black paste, petroleum odour.

### 4. HEALTH HAZARD INFORMATION

#### NATURE OF HAZARD

#### INHALATION:

Negligible hazard at normal temperatures (up to 38 deg C).  
 Elevated temperatures or mechanical action may form vapours, mists or fumes which may be irritating to the eyes, nose, throat and lungs.  
 Avoid breathing vapours or mists.

#### EYE CONTACT:

Slightly irritating, but will not injure eye tissue.

#### SKIN CONTACT:

Low toxicity.  
 Frequent or prolonged contact may irritate the skin.  
 High pressure greasing equipment is capable of injecting grease under the skin which may have severe health consequences.

#### INGESTION:

Low toxicity.  
 Small amounts of this liquid drawn into the lungs from swallowing or vomiting may cause severe health effects (e.g. bronchopneumonia or pulmonary edema).

**ACUTE TOXICITY DATA:**

Based on animal testing data from similar materials and products, the acute toxicity of this product is expected to be:

Oral : LD50 > 5000 mg/kg (Rat)  
Dermal : LD50 > 3160 mg/kg (Rabbit)  
Inhalation : LC50 > 5000 mg/m3 (Rat)

**OCCUPATIONAL EXPOSURE LIMIT:****ACGIH recommends:**

For insoluble Molybdenum compounds, 10 mg/m3.  
For oil mists, 5 mg/m3.

Local regulated limits may vary.

---

**5. FIRST AID MEASURES****INHALATION:**

In case of adverse exposure to vapours, mists and/or fumes formed at elevated temperature, or by mechanical action, immediately remove the affected victim from exposure. Administer artificial respiration if breathing has stopped. Keep at rest. Call for prompt medical attention.

**EYE CONTACT:**

Flush eyes with large amounts of water until irritation subsides. If irritation persists, get medical attention.

**SKIN CONTACT:**

Flush with large amounts of water. Use soap if available. Remove severely contaminated clothing (including shoes) and launder before reuse. If irritation persists, seek medical attention. Consult a physician immediately if the material is injected under the skin from the misuse of high pressure greasing equipment.

**INGESTION:**

DO NOT induce vomiting since it is important that no amount of the material should enter the lungs (aspiration). Keep at rest. Get prompt medical attention.

---

**6. PREVENTIVE AND CORRECTIVE MEASURES****PERSONAL PROTECTION:**

The selection of personal protective equipment varies, depending upon

conditions of use.

In open systems where contact is likely, wear safety goggles, chemical-resistant overalls, and chemically impervious gloves.

Where only incidental contact is likely, wear safety glasses with side shields. No other special precautions are necessary provided skin/eye contact is avoided.

Where concentrations in air may exceed the occupational exposure limits given in Section 4 and where engineering, work practices or other means of exposure reduction are not adequate, approved respirators may be necessary to prevent overexposure by inhalation.

#### **ENGINEERING CONTROLS:**

The use of local exhaust ventilation is recommended to control emissions near the source. Laboratory samples should be handled in a fumehood. Provide mechanical ventilation of confined spaces.

#### **HANDLING, STORAGE AND SHIPPING:**

Keep containers closed. Handle and open containers with care.

Store in a cool, well ventilated place away from incompatible materials.

In keeping with good personal hygiene practices, wash hands thoroughly after handling the material.

Store and load at normal (up to 38 deg C) temperature and at atmospheric pressure.

Empty containers may contain product residue. Do not pressurize cut, heat, or weld empty containers. Do not reuse empty containers without commercial cleaning or reconditioning.

#### **LAND SPILL:**

Eliminate source of ignition. Keep public away. Prevent additional discharge of material, if possible to do so without hazard.

Prevent spills from entering sewers, watercourses or low areas. Contain spilled liquid with sand or earth.

Allow material to solidify and scrape up. Place material in suitable containers for recycle or disposal.

Consult an expert on disposal of recovered material. Ensure disposal in compliance with government requirements and ensure conformity to local disposal regulations. Notify the appropriate authorities immediately.

Take all additional action necessary to prevent and remedy the adverse effects of the spill.

#### **WATER SPILL:**

Remove from surface by skimming or with suitable absorbents. If allowed by local authorities and environmental agencies, sinking and/or suitable dispersants may be used in unconfined waters.

Consult an expert on disposal of recovered material. Ensure disposal in compliance with government requirements and ensure conformity to local disposal regulations. Notify the appropriate authorities immediately.

Take all additional action necessary to prevent and remedy the adverse effects of the spill.

## 7. FIRE AND EXPLOSION HAZARD

Flashpoint and method: >110 deg C COC ASTM D92 est.baseoil

Autoignition: NA Flammable Limits: LEL: NA UEL: NA

### GENERAL HAZARDS:

Low Hazard; liquids may burn upon heating to temperatures at or above the flash point.

Decomposes; flammable/toxic gases will form at elevated temperatures (thermal decomposition).

Toxic gases will form upon combustion.

### FIRE FIGHTING:

Use water spray to cool fire exposed surfaces and to protect personnel. Shut off fuel to fire.

Use foam, dry chemical or water spray to extinguish fire.

Respiratory and eye protection required for fire fighting personnel.

A self-contained breathing apparatus (SCBA) should be used for all indoor fires and any significant outdoor fires. For small outdoor fires, which may easily be extinguished with a portable fire extinguisher, use of an SCBA may not be required.

### HAZARDOUS COMBUSTION PRODUCTS:

Smoke, carbon monoxide, carbon dioxide and traces of oxides of sulphur

---

## 8. REACTIVITY DATA

### STABILITY:

This product is stable. Hazardous polymerization will not occur.

### INCOMPATIBLE MATERIALS AND CONDITIONS TO AVOID:

Strong oxidizing agents

### HAZARDOUS DECOMPOSITION:

Fumes, smoke, carbon monoxide and sulphur oxides in case of incomplete combustion

---

## 9. NOTES

All components of this product are listed on the U.S. TSCA inventory.

.

REVISION SUMMARY:

Since 17 September 1998, this MSDS has been revised in Section(s):  
1, 7

---

## 10. PREPARATION

Date Prepared: November 14, 2003  
Prepared by: Lubricants & Specialties  
IMPERIAL OIL  
Products Division  
111 St Clair Avenue West  
Toronto, Ontario  
M5W 1K3  
(800) 268-3183

---

CAUTION: " The information contained herein relates only to this product or material and may not be valid when used in combination with any other product or material or in any process. If the product is not to be used for a purpose or under conditions which are normal or reasonably foreseeable, this information cannot be relied upon as complete or applicable. For greater certainty, uses other than those described in Section 1 must be reviewed with the supplier. The information contained herein is based on the information available at the indicated date of preparation. This MSDS is for the use of Imperial Oil customers and their employees and agents only. Any further distribution of this MSDS by Imperial Oil customers is prohibited without the written consent of Imperial Oil."

## **APPENDIX V**

### **Fuel Bladder Design, Layout and Specifications**

REV	REVISION DESCRIPTION	BY	DATE	APPV
P1	PRELIMINARY	GB	24.12.11	-
P2	HOSE LENGTHS AND QTY REVISED PER CUSTOMER REQUEST	MJ	25.07.04	-

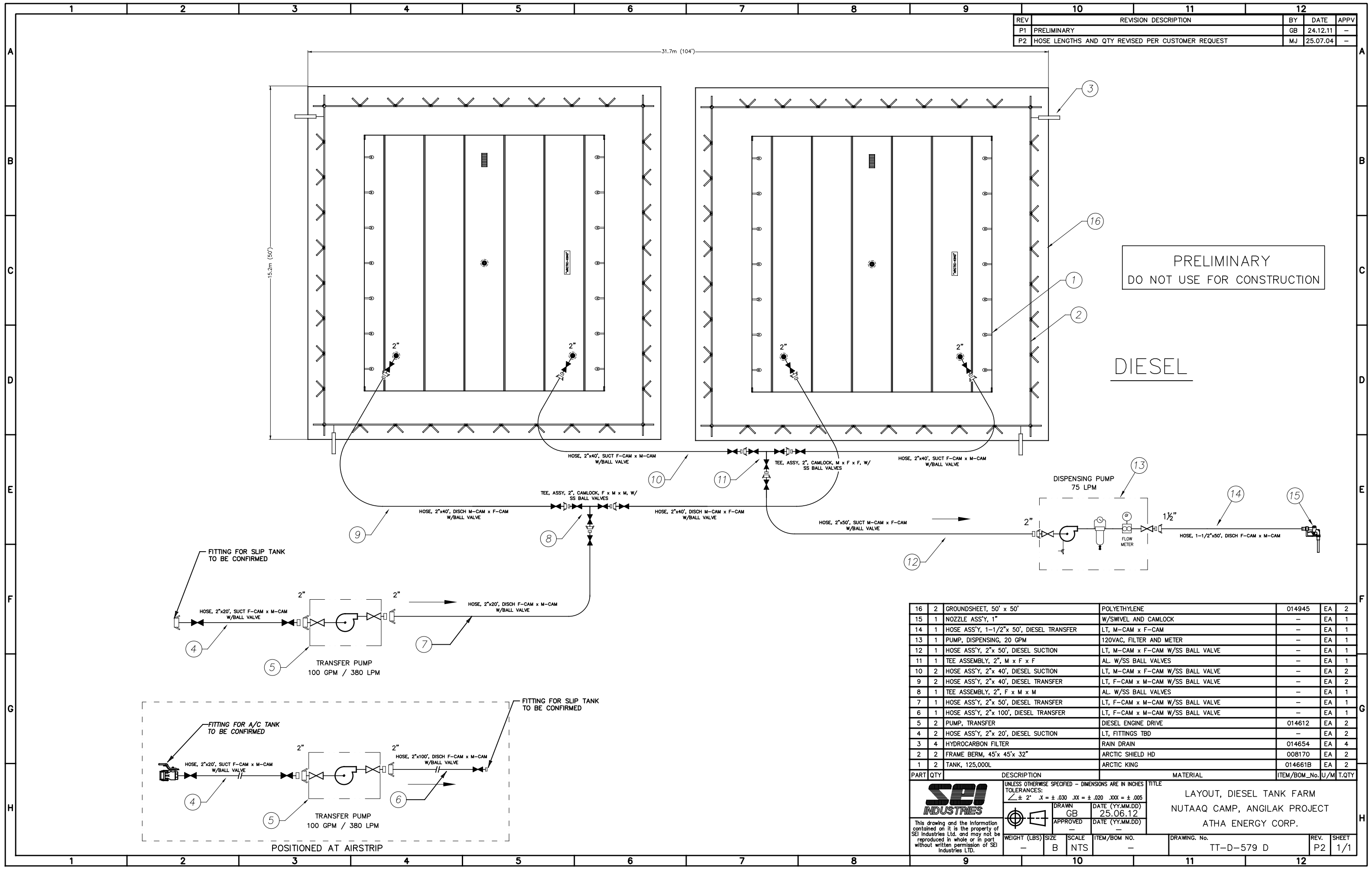

PRELIMINARY  
DO NOT USE FOR CONSTRUCTION

DIESEL

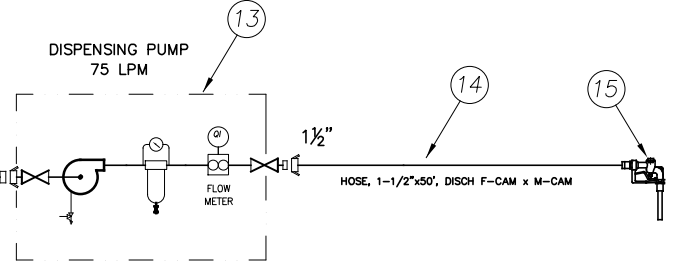
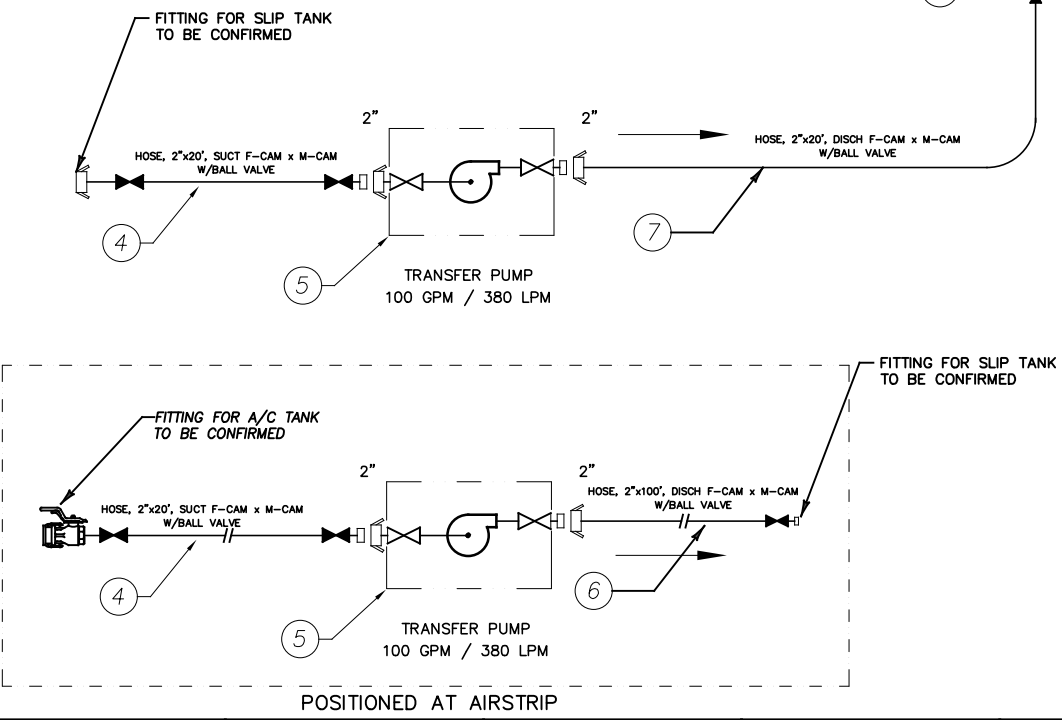

PART	QTY	DESCRIPTION	MATERIAL	ITEM/BOM_No.	U/M	T.QTY
16	2	GROUNDSHEET, 50' x 50'	POLYETHYLENE	014945	EA	2
15	1	NOZZLE ASS'Y, 1"	W/SWIVEL AND CAMLOCK	-	EA	1
14	1	HOSE ASS'Y, 1-1/2" x 50', DIESEL TRANSFER	LT, M-CAM x F-CAM	-	EA	1
13	1	PUMP, DISPENSING, 20 GPM	120VAC, FILTER AND METER	-	EA	1
12	1	HOSE ASS'Y, 2" x 50', DIESEL SUCTION	LT, M-CAM x F-CAM W/SS BALL VALVE	-	EA	1
11	1	TEE ASSEMBLY, 2", M x F x F	AL. W/SS BALL VALVES	-	EA	1
10	2	HOSE ASS'Y, 2" x 40', DIESEL SUCTION	LT, M-CAM x F-CAM W/SS BALL VALVE	-	EA	2
9	2	HOSE ASS'Y, 2" x 40', DIESEL TRANSFER	LT, F-CAM x M-CAM W/SS BALL VALVE	-	EA	2
8	1	TEE ASSEMBLY, 2", F x M x M	AL. W/SS BALL VALVES	-	EA	1
7	1	HOSE ASS'Y, 2" x 50', DIESEL TRANSFER	LT, F-CAM x M-CAM W/SS BALL VALVE	-	EA	1
6	1	HOSE ASS'Y, 2" x 100', DIESEL TRANSFER	LT, F-CAM x M-CAM W/SS BALL VALVE	-	EA	1
5	2	PUMP, TRANSFER	DIESEL ENGINE DRIVE	014612	EA	2
4	2	HOSE ASS'Y, 2" x 20', DIESEL SUCTION	LT, FITTINGS TBD	-	EA	2
3	4	HYDROCARBON FILTER	RAIN DRAIN	014654	EA	4
2	2	FRAME BERM, 45' x 45' x 32"	ARCTIC SHIELD HD	008170	EA	2
1	2	TANK, 125,000L	ARCTIC KING	014661B	EA	2

**SEI INDUSTRIES**

UNLESS OTHERWISE SPECIFIED - DIMENSIONS ARE IN INCHES  
TOLERANCES:  
∠ ± 2° .X = ± .030 .XX = ± .020 .XXX = ± .005

DRAWN: GB DATE: 25.06.12  
APPROVED: DATE: (YY.MM.DD)

WEIGHT (LBS): - SIZE: B SCALE: NTS ITEM/BOM No.: - DRAWING No.: TT-D-579 D REV: P2 SHEET: 1/1

TITLE: LAYOUT, DIESEL TANK FARM  
NUTAAQ CAMP, ANGLAK PROJECT  
ATHA ENERGY CORP.

REV	REVISION DESCRIPTION	BY	DATE	APPV
P1	PRELIMINARY	GB	24.12.11	-
P2	HOSE LENGTHS AND QTY REVISED PER CUSTOMER REQUEST	MJ	25.07.04	-

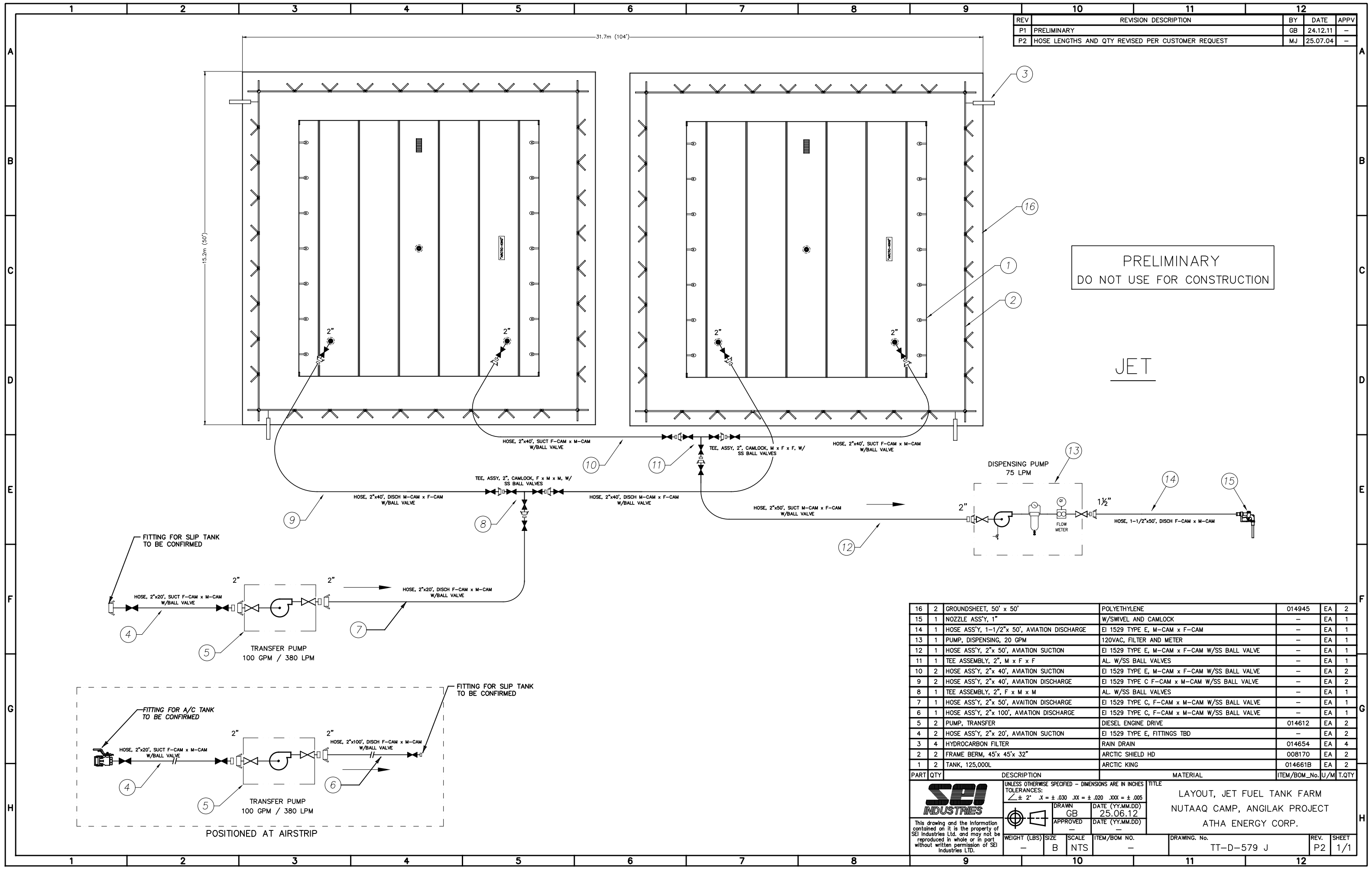

PRELIMINARY  
DO NOT USE FOR CONSTRUCTION

JET

PART	QTY	DESCRIPTION	MATERIAL	ITEM/BOM_No.	U/M	T.QTY
16	2	GROUNDSHEET, 50' x 50'	POLYETHYLENE	014945	EA	2
15	1	NOZZLE ASS'Y, 1"	W/SWIVEL AND CAMLOCK	-	EA	1
14	1	HOSE ASS'Y, 1-1/2"x 50', AVIATION DISCHARGE	EI 1529 TYPE E, M-CAM x F-CAM	-	EA	1
13	1	PUMP, DISPENSING, 20 GPM	120VAC, FILTER AND METER	-	EA	1
12	1	HOSE ASS'Y, 2"x 50', AVIATION SUCTION	EI 1529 TYPE E, M-CAM x F-CAM W/SS BALL VALVE	-	EA	1
11	1	TEE ASSEMBLY, 2", M x F x F	AL. W/SS BALL VALVES	-	EA	1
10	2	HOSE ASS'Y, 2"x 40', AVIATION SUCTION	EI 1529 TYPE E, M-CAM x F-CAM W/SS BALL VALVE	-	EA	2
9	2	HOSE ASS'Y, 2"x 40', AVIATION DISCHARGE	EI 1529 TYPE C F-CAM x M-CAM W/SS BALL VALVE	-	EA	2
8	1	TEE ASSEMBLY, 2", F x M x M	AL. W/SS BALL VALVES	-	EA	1
7	1	HOSE ASS'Y, 2"x 50', AVIATION DISCHARGE	EI 1529 TYPE C, F-CAM x M-CAM W/SS BALL VALVE	-	EA	1
6	1	HOSE ASS'Y, 2"x 100', AVIATION DISCHARGE	EI 1529 TYPE C, F-CAM x M-CAM W/SS BALL VALVE	-	EA	1
5	2	PUMP, TRANSFER	DIESEL ENGINE DRIVE	014612	EA	2
4	2	HOSE ASS'Y, 2"x 20', AVIATION SUCTION	EI 1529 TYPE E, FITTINGS TBD	-	EA	2
3	4	HYDROCARBON FILTER	RAIN DRAIN	014654	EA	4
2	2	FRAME BERM, 45'x 45'x 32"	ARCTIC SHIELD HD	008170	EA	2
1	2	TANK, 125,000L	ARCTIC KING	014661B	EA	2

**SEI INDUSTRIES**

UNLESS OTHERWISE SPECIFIED - DIMENSIONS ARE IN INCHES  
TOLERANCES:  
∠ ± 2° .X = ± .030 .XX = ± .020 .XXX = ± .005

THIS DRAWING AND THE INFORMATION CONTAINED ON IT IS THE PROPERTY OF SEI INDUSTRIES LTD. AND MAY NOT BE REPRODUCED IN WHOLE OR IN PART WITHOUT WRITTEN PERMISSION OF SEI INDUSTRIES LTD.

**TITLE**  
LAYOUT, JET FUEL TANK FARM  
NUTAAQ CAMP, ANGLAK PROJECT  
ATHA ENERGY CORP.

DRAWN: GB  
APPROVED: -  
DATE (YY.MM.DD): 25.06.12  
DATE (YY.MM.DD): -

WEIGHT (LBS): -  
SIZE: B  
SCALE: NTS  
ITEM/BOM No.: -  
DRAWING No.: TT-D-579 J  
REV: P2  
SHEET: 1/1



# AUTHORIZATION TO MARK

This authorizes the application of the Certification Mark(s) shown below to the models described in the Product(s) Covered section when made in accordance with the conditions set forth in the Certification Agreement and Listing Report(s). This authorization also applies to the Multiple Listee model(s) identified on the correlation page of the Listing Report.

This document is the property of Intertek Testing Services and is not transferable. The Certification Mark(s) may be applied only at the location of the Party Authorized to Apply Mark.

**Applicant:** SEI Industries Ltd.  
 7400 Wilson Avenue  
 Delta, BC V4G 1H3  
 Canada

**Contact:** Barry Wright

**Phone:** 604-946-3131

**Email:** barry@sei-ind.com

**Party Authorized to Apply Mark:** See following page(s)

**Evaluation Center:** Intertek (Coquitlam)

**Client Number:** 107425

Authorized By:   
**Jean-Philippe Kayl, Director of Certification**

Intertek Testing Services NA, Inc.  
 545 E. Algonquin Road, Ste H., Arlington Heights, IL 60005 USA  
 Phone: 847-439-5667 Fax: 847-439-7320



This document supersedes all previous Authorizations to Mark for the noted Report Number.

This Authorization to Mark is for the exclusive use of Intertek's Client and is provided pursuant to the Certification agreement between Intertek and its Client. Intertek's responsibility and liability are limited to the terms and conditions of the agreement. Intertek assumes no liability to any party, other than to the Client in accordance with the agreement, for any loss, expense or damage occasioned by the use of this Authorization to Mark. Only the Client is authorized to permit copying or distribution of this Authorization to Mark and then only in its entirety. Use of Intertek's Certification mark is restricted to the conditions laid out in the agreement and in this Authorization to Mark. Any further use of the Intertek name for the sale or advertisement of the tested material, product or service must first be approved in writing by Intertek. Initial Factory Assessments and Follow up Services are for the purpose of assuring appropriate usage of the Certification mark in accordance with the agreement, they are not for the purposes of production quality control and do not relieve the Client of their obligations in this respect.

<b>Testing Standard(s):</b>	CSA B837 (2014)
<b>Product:</b>	SEI Industries - Collapsible Fabric Storage Tanks

**ATM for Report:** G101912920

**ATM Issue Date:** 6/21/2019

**Listing Section(s):** FLAMMABLE AND COMBUSTIBLE LIQUID TANKS

**CSI Code(s):** 13 00 00 Special Construction

**Description:**

**Collapsible Fabric Storage Tanks**

The SEI Industries Ltd. (SEI) products are fabricated, above ground, collapsible tanks used for the storage of petroleum fuel and related petroleum products. The tanks are made using reinforcing scrims with specifically formulated coatings on both the internal tank and external tank sides of the fabric. The storage capacity of the tanks is limited to a maximum of 125,000 L. The three tank products fabricated by SEI are described below:

**Arctic King** – Designed for liquid fuel storage in sub-zero climates to -50°C

**Desert King** – Designed for liquid fuel storage in desert environments

**Jungle King** – Designed for liquid fuel in hot, humid, and wet climates

Test Standard	Test Type	Rating
CSA B837	Material, System Performance and Resistance	Conforms

**Party(s) Authorized by Manufacturer To Apply Mark:**

SEI Industries Ltd.  
7400 Wilson Avenue  
Delta, BC V4G 1H3  
Canada  
Contact: Barry Wright  
Phone: 604-946-3131  
Email: barry@sei-ind.com

**Party(s) Authorized by Other Parties To Apply Mark:**

None



October 1, 2025

Cliff Revering  
Atha Energy Corp.  
301 - 331 1st Ave N.  
Saskatoon SK  
S7K 1X5

Dear Cliff,

In response to your email dated October 1, 2025, I can confirm that SEI's Arctic King fuel bladders conform to the design standards set out in CAN/CSA-B837-14 - Collapsible Fabric Storage Tanks (bladders).

Each bladder is marked with an ETL mark indicating such conformity. ETL marking is approved on a continuous basis by Intertek Testing Services.

Please let me know if you have any questions or require further information.

Thank you,

Robin Cnudde

A handwritten signature in dark ink, appearing to read 'R. Cnudde', is written over a light blue grid background.

Regional Manager